





New

SERIE CG01 - CILINDRI CON GUIDA INTEGRATA

DOUBLE-ACTING MAGNETIC TWIN-GUIDE CYLINDERS
 ZYLINDER MIT INTEGRIERTER FÜHRUNG
 VÉRINS AVEC GUIDE INTÉGRÉ
 CILINDROS CON VÁSTAGOS PARALELOS DOBLE EFECTO MAGNETICO
 CILINDRO DUPLA AÇÃO MAGNÉTICO COM GUIA DUPLA

 **CARATTERISTICHE TECNICHE**
 TECHNICAL CHARACTERISTICS
 TECHNISCHE ANGABEN
 CARACTÉRISTIQUES TECHNIQUES
 CARACTERÍSTICAS TÉCNICAS
 CARACTERÍSTICAS TÉCNICAS



-  1907/2006 REACH
-  2011/65/CE RoHS
-  PED 2014/68/UE

Materiali	IT	Materials	GB	Materialien	DE
<ul style="list-style-type: none"> • Corpo: Lega alluminio • Piastra: Acciaio • Stelo: Ø 12÷20 acciaio inox Ø 25÷63 Acciaio • Magnete: Plastroferrite • Guarnizioni: NBR • Ammortizzatore: NBR 		<ul style="list-style-type: none"> • Body: Aluminum alloy • Plate: Carbon Steel • Piston rod: Ø 12÷20 Stainless steel Ø 25÷63 Carbon Steel • Magnet: Plastroferrite • NBR seals • Cushion: NBR 		<ul style="list-style-type: none"> • Körper: Aluminium Legierung • Platte: Stahl • Kolbenstange: R 12÷20 Edelstahl R 25÷63 Stahl • Magnet: Plastroferrit • Dichtungen: NBR • Stossdämpfer: NBR 	
Matériaux	FR	Materiales	ES	Materiais	PT
<ul style="list-style-type: none"> • Corps : Alliage d'aluminium • Plaque : Acier • Tige: Ø 12÷20 acier inox Ø 25÷63 Acier • Aimant : Plastroferrite • Joints : NBR • Amortissement : NBR 		<ul style="list-style-type: none"> • Cuerpo: Aleación de aluminio • Placa: Acero • Vástago: Ø 12÷20 acero inox Ø 25÷63 Acero • Magnete: Plastroferrita • Juntas: NBR • Amortiguación: NBR 		<ul style="list-style-type: none"> • Corpo: Liga de aluminio • Placa: Aço • Haste: Ø 12÷20 aço inox Ø 25÷63 Aço • Magnético: Plastroferrite • Vedações: NBR • Amortecimento: NBR 	

 **Pressioni**
 Pressures
 Druckbereich
 Pressions
 Presiones
 Pressões

1 bar (0.1 MPa)
10 bar (1 MPa)

 **Temperature**
 Temperatures
 Temperatur
 Températures
 Temperaturas
 Temperaturas

-5 °C (No freezing)
+ 60 °C

 **Fluidi compatibili**
 Aria (Lubrificazione non necessaria).
 Fluids
 Air (Lubrication not necessary).
 Geeignete Medien
 Luft (Schmierung nicht erforderlich).
 Fluides compatibles
 Air (Lubrification pas nécessaire).
 Fluidos compatibles
 Aire (Lubrificación no necesaria).
 Fluidos compatíveis
 Ar (Lubrificação não necessária).

 **Alesaggi**
 Bores
 Durchmesser
 Diamètres
 Diámetros
 Diâmetros

12-16-20-25-32-40-50-63 mm

 **Range velocità**
 Speed range
 Verfügbarer Geschwindigkeitsbereich
 Plage de vitesse disponible
 Rango velocidad
 Range de velocidades

50 mm/sec
500 mm/sec



Peso cilindro

Cylinder Weight

Zylinder Gewicht

Poids du vérin

Peso Cilindro

Peso do Cilindro

Ø	Standard stroke (mm)	
	Basic weight	Stroke 5 mm
12	191	21
16	283	28
20	450	45
25	670	63
32	1,210	90
40	1,474	88
50	2,540	140
63	3,345	157

(Unit: g)



Sensori consigliati

Sensors recommended

Empfohlene Sensoren

Capteurs recommandés

Sensores recomendados

Sensores aconselhados

DC 01 RM8
DC 01 R2M

DC 03 PM8
DC 03 P2M

DC 04 PM8
DC 04 P2M



Tabella dei codici di ordinazione

Ordering codes

Bestellschlüssel

Code de commande

Tabla de codificación para pedidos

Tabela de codificação para compra

SERIE	Ø mm	Corsa Stroke Hub Course Carrera Curso mm
-------	---------	--

C G 0 1

0 1 2

0 0 1 0

012
016
020
025
032
040
050
063

0010
0020
0025
0030
0040
0050
0075
0100
0125
0150
0175
0200
0250
0300
0350
0400

Ø mm	10	20	25	30	40	50	75	100	125	150	175	200	250	300	350	400
12	▲	▲		▲	▲	▲	▲	▲	▲	▲	▲	▲	▲			
16	▲	▲		▲	▲	▲	▲	▲	▲	▲	▲	▲	▲			
20		▲		▲	▲	▲	▲	▲	▲	▲	▲	▲	▲	▲	▲	▲
25		▲		▲	▲	▲	▲	▲	▲	▲	▲	▲	▲	▲	▲	▲
32			▲			▲	▲	▲	▲	▲	▲	▲	▲	▲	▲	▲
40			▲			▲	▲	▲								
50			▲			▲	▲	▲								
63			▲			▲	▲	▲								

CG01 Ø 12 ÷ Ø 32

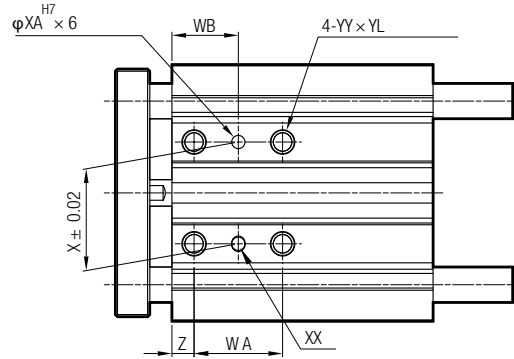

Back side

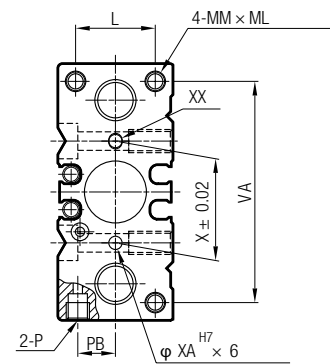
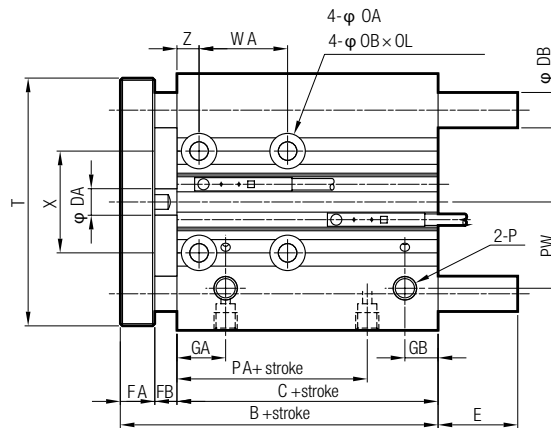
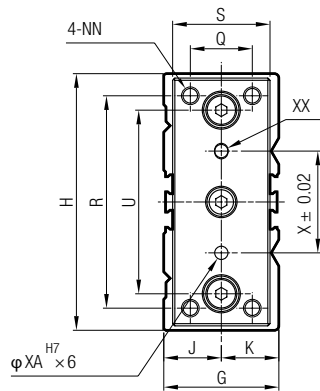
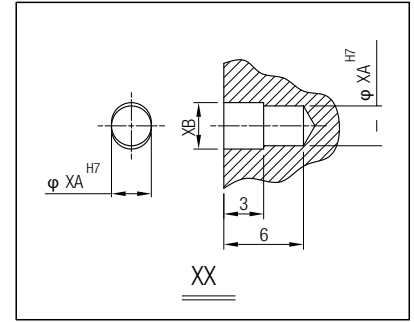

Ø	B	C	DA	DB	FA	FB	G	GA	GB	H	J	K	L	MM	ML	NN	OA	OB	OL
12	42	29	6	8	8	5	26	11	15*	58	13	13	18	M4 x 0,7	10	M4 x 0,7	4,3	8,0	4,5
16	46	33	8	10	8	5	30	11	18**	64	15	15	22	M5 x 0,8	12	M5 x 0,8	4,3	8,0	4,5
20	53	37	10	12	10	6	36	10,5	8,5	85	17	19	24	M5 x 0,8	13	M5 x 0,8	5,2	9,5	5,5
25	53,5	37,5	12	16	10	6	42	11,5	9	96	21	21	30	M6 x 1,0	15	M6 x 1,0	5,2	9,5	5,5
32	59,5	37,5	16	20	12	10	51	12,5	9	116	26	25	34	M8 x 1,25	20	M8 x 1,25	6,6	11,0	7,5

Ø	P	PA	PB	PW	Q	R	S	T	U	VA	X	XA	XB	YY	YL	Z
12	M5 x 0,8	14	8,5	18	14	48	22	56	41,5	50	23	3	3,5	M5 x 0,8	10	5
16	M5 x 0,8	15	10,0	19	16	54	25	62	46	56	24	3	3,5	M5 x 0,8	10	5
20	G 1/8	12,5	11,5	25	18	70	30	81	55	72	28	3	3,5	M6 x 1,0	12	17
25	G 1/8	12,5	13,5	28,5	26	78	38	91	65	82	34	4	4,5	M6 x 1,0	12	17
32	G 1/8	7	16,0	34	30	96	44	110	80	98	42	4	4,5	M8 x 1,25	16	21

* Quando la lunghezza della corsa è pari a 19mm o inferiore, GB=7,5mm
 When stroke length is equal to 19 mm or less, GB=7,5 mm
 Wenn Hublänge gleich 19 mm oder weniger, GB=7,5 mm
 Lorsque la longueur de la course est égale ou inférieure à 19mm, GB=7,5mm
 Cuando la longitud de la carrera es igual a 19 mm o menor, GB=7,5 mm
 Quando o curso do cilindro é igual ou inferior a 19mm, GB=7,5mm

** Quando la lunghezza della corsa è pari a 19mm o inferiore, GB=9mm
 When stroke length is equal to 19 mm or less, GB=9 mm
 Wenn Hublänge gleich 19 mm oder weniger, GB=9mm
 Lorsque la longueur de la course est égale ou inférieure à 19mm, GB=9mm
 Cuando la longitud de la carrera es igual a 19 mm o menor, GB=9 mm
 Quando o curso do cilindro é igual ou inferior a 19mm, GB= 9mm

Ø	WA					WB				
	~39st	40~100st	125~200st	201~300st	301st~	20~39st	40~100st	125~200st	201~300st	301st
12	20	40	110	200	-	15	25	60	105	-
16	24	44	110	200	-	17	27	60	105	-
20	24	44	120	200	300	29	39	77	117	167
25	24	44	120	200	300	29	39	77	117	167

Ø	WA					WB				
	25~49st	50~100st	125~200st	201~300st	301st~	25~49st	50~100st	125~200st	201~300st	301st~
32	24	48	124	200	300	33	45	83	121	171

CG01 Ø 40 ÷ Ø 63

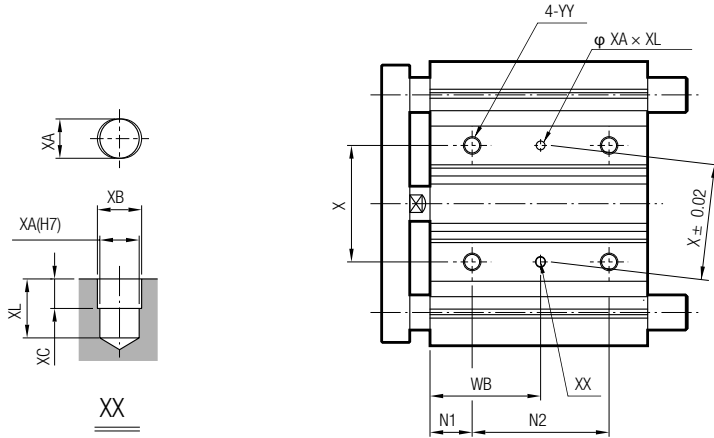

Back side

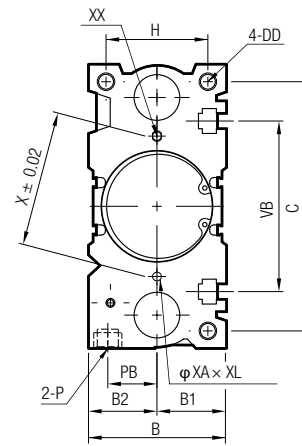
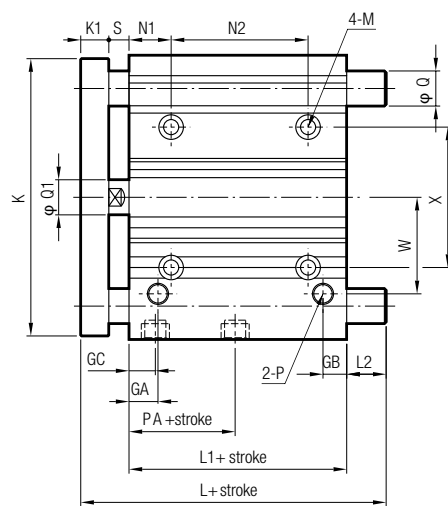
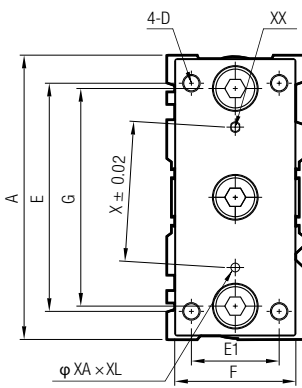
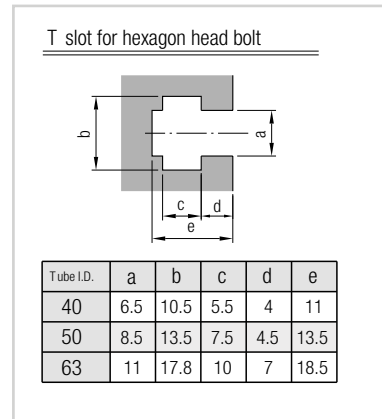

Ø	A	B	B1	B2	C	D	DD	E	E1	F	G	GA	GB	GC	H	K	K1	L1	M
40	120	54	27	27	106	M8x1,25	M8x1,25x20	104	30	44	86	14	10	14	40	118	12	44	ø6,6 - ø11x7,5
50	148	64	32	32	130	M10x1,5	M10x1,5x22	130	40	60	110	14	11	12	46	146	16	44	ø8,6 - ø14x9
63	162	78	39	39	142	M10x1,5	M10x1,5x22	130	50	70	124	16,5	13,5	16,5	58	158	16	49	ø8,6 - ø14x9

Ø	N1	P	PA	PB	Q1	S	VB	W	X	XA ^{H7}	XB	XC	XL	YY	N2			WB		
															25st	50-75-100 st	100st~	25st	50-75-100 st	100st~
40	22	G 1/8	13	18	16	10	72	38	50	4	4,5	3	6	M8x1,25x16	24	48	124	34	46	84
50	24	G 1/4	9	21,5	20	12	92	47	66	5	6	4	8	M10x1,5x20	24	48	124	36	48	86
63	24	G 1/4	14	28	20	12	110	55	80	5	6	4	8	M10x1,5x20	28	52	128	38	50	88

Ø	L		L2		Q
	25-50st	50st~	25-50st	50st~	
40	97	102	31	36	ø20
50	106,5	118	34,5	46	ø25
63	106,5	118	29,5	41	ø25

**FORZE E CONSUMI**

FORCES AND CONSUMPTIONS

KRÄFTE UND LUFTVERBRAUCH

FORCES ET CONSOMMATIONS D'AIR

FUERZAS Y CONSUMOS

FORÇAS E CONSUMOS

Forze di spinta e tiro - Thrust and traction forces - Schub-und zugkräfte - Force de poussée et de traction - Fuerza de empuje y tracción - Força de avanço e recuo.

Ø Cilindro Cylinder Zylinder Vérins Cilindro Cilindro	Ø Stelo Rod Stange Tige Vástago Haste	Superficie spinta Pushing surface Schubfläche Surface de poussée Superficie de empuje Área de avanço	Superficie trazione Traction surface Zugfläche Surface de traction Superficie de tracción Área de retorno		Pressione di lavoro Operating pressure Betriebsdruck Pression de service Presión de trabajo Pressão de operação									
mm	mm	mm ²	mm ²		bar									
					1	2	3	4	5	6	7	8	9	10
					Forza sviluppata Output force Zylinderkraft Force du vérin Fuerza desarrollada Força desenvolvida N									
12	6	113,04	84,78	S =	10	20	30	40	50	59,9	69,9	79,8	89,8	99,8
				T =	7,5	15	22,5	30	37,5	44,9	52,4	59,9	67,4	74,9
16	8	200,96	150,72	S =	17,7	35,5	53	71	88,7	106,5	124	141,9	159,7	177,4
				T =	13,3	26,6	39,9	53,2	66,5	79,8	93	106,5	119,7	133
20	10	314,00	235,50	S =	27,7	55,4	83,1	110,9	138,6	166,3	194	221,8	249,5	277,23
				T =	20,8	41,6	62,4	83,2	104	124,8	145,5	166,3	187,1	207,9
25	12	490,62	377,58	S =	43,3	86,6	130	173,3	216,6	259,9	303,2	346,5	389,8	433,1
				T =	33,3	66,7	100	133,3	166,7	200	233,3	266,7	300	333,4
32	16	803,84	602,88	S =	71	141,9	212,9	283,8	354,9	425,8	496,8	567,8	638,7	709,7
				T =	53,2	106,5	159,7	212,9	266,1	319,4	372,6	425,8	479	532,2
40	16	1256,00	1055,04	S =	110,9	221,8	332,6	443,5	554,5	665,4	776,2	887,1	998	1108,9
				T =	93,1	186,3	279,4	372,6	465,7	558,9	652	745,2	838,3	931,5
50	20	1962,50	1648,50	S =	173,3	346,5	519,8	693	866,3	1039,6	1212,9	1386,1	1559,4	1732,7
				T =	145,5	291	436,6	582,1	727,7	873,2	1018,8	1164,4	1310	1455,5
63	20	3115,66	2801,66	S =	275,1	550,1	825,2	1100,3	1375,4	1650,5	1925,6	2200,6	2475,7	2750,8
				T =	247,4	494,7	742	989,4	1236,8	1484,1	1731,5	1978,9	2226,2	2473,6

S Spinta - Thrust - Schub - Poussée - Empuje - Avanço**T** Trazione - Traction - Zugkraft - Tracción - Tracción - Recuo

Consumi cilindro - Cylinder air consumption - Zylinder Luftverbrauch - Consommation d'air des vérins - Consumo cilindro - Consumo de ar do cilindro.

Ø Cilindro Cylinder Zylinder Vérins Cilindro Cilindro	Ø Stelo Rod Stange Tige Vástago Haste	Superficie spinta Pushing surface Schubfläche Surface de poussée Superficie de empuje Área de avanço	Superficie trazione Traction surface Zugfläche Surface de traction Superficie de tracción Área de retorno		Pressione di lavoro Operating pressure Betriebsdruck Pression de service Presión de trabajo Pressão de operação									
mm	mm	mm ²	mm ²		bar									
					1	2	3	4	5	6	7	8	9	10
					Consumo aria per ogni 10 mm di corsa Air consumption for each 10 mm of stroke Luftverbrauch pro 10 mm Hub Consommation d'air par 10 mm de course Consumo aire para cada 10 mm de carrera Consumo de ar para cada 10 mm de curso NL									
12	6	113,04	84,78	S =	0,00226	0,00452	0,00678	0,00904	0,01130	0,01356	0,01583	0,01809	0,02035	0,02261
				T =	0,00170	0,00339	0,00509	0,00678	0,00848	0,01017	0,01187	0,01356	0,01526	0,01696
16	8	200,96	150,72	S =	0,00402	0,00804	0,01206	0,01608	0,02010	0,02412	0,02813	0,03215	0,03617	0,04019
				T =	0,00301	0,00603	0,00904	0,01206	0,01507	0,01809	0,02110	0,02412	0,02713	0,03014
20	10	314,00	235,50	S =	0,00628	0,01256	0,01884	0,02512	0,03140	0,03768	0,04396	0,05024	0,05652	0,06280
				T =	0,00471	0,00942	0,01413	0,01884	0,02355	0,02826	0,03297	0,03768	0,04239	0,04710
25	12	490,62	377,58	S =	0,00981	0,01963	0,02944	0,03925	0,04906	0,05888	0,06869	0,07850	0,08831	0,09813
				T =	0,00755	0,01510	0,02266	0,03021	0,03776	0,04531	0,05286	0,06041	0,06797	0,07552
32	16	803,84	602,88	S =	0,01608	0,03215	0,04823	0,06431	0,08038	0,09646	0,11254	0,12861	0,14469	0,16077
				T =	0,01206	0,02412	0,03617	0,04823	0,06029	0,07235	0,08440	0,09646	0,10852	0,12058
40	16	1256,00	1055,04	S =	0,02512	0,05024	0,07536	0,10048	0,12560	0,15072	0,17584	0,20096	0,22608	0,25120
				T =	0,02110	0,04220	0,06330	0,08440	0,10550	0,12660	0,14771	0,16881	0,18991	0,21101
50	20	1962,50	1648,50	S =	0,03925	0,07850	0,11775	0,15700	0,19625	0,23550	0,27475	0,31400	0,35325	0,39250
				T =	0,03297	0,06594	0,09891	0,13188	0,16485	0,19782	0,23079	0,26376	0,29673	0,32970
63	20	3115,66	2801,66	S =	0,06231	0,12463	0,18694	0,24925	0,31157	0,37388	0,43619	0,49851	0,56082	0,62313
				T =	0,05603	0,11207	0,16810	0,22413	0,28017	0,33620	0,39223	0,44827	0,50430	0,56033

S Spinta - Thrust - Schub - Poussée - Empuje - Avanço**T** Trazione - Traction - Zugkraft - Tracción - Tracción - Recuo

CARICO MASSIMO LATERALE AMMISSIBILE DI LAVORO

ALLOWABLE LATERAL LOAD

MAXIMAL ZULAESSIGE HORIZONTAL EN KRAEFTE

CHARGE MAXIMALE LATERALE DE TRAVAIL ADMISSIBLE

CARGA MÁXIMA LATERAL ADMISIBILE DE TRABAJO

CARGA MÁXIMA LATERAL ADMISÍVEL

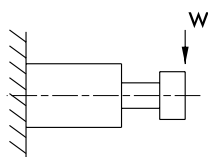

Ø	Stroke (mm)															
	10	20	25	30	40	50	75	100	125	150	175	200	250	300	350	400
12	31	24	-	19	16	13	37	31	15	13	12	10	9	-	-	-
16	50	39	-	32	27	24	54	45	27	24	21	19	16	-	-	-
20	-	51	-	44	39	35	54	46	74	66	59	54	28	24	21	19
25	-	68	-	59	52	46	72	61	98	88	79	72	53	46	41	37
32	-	-	165	-	-	129	106	90	138	123	111	101	88	77	68	61

(Unit: N)

COPPIA MASSIMA AMMISSIBILE DI ROTAZIONE

ALLOWABLE ROTATING TORQUE

MAXIMAL ZULAESSIGE ROTATIONS KRÄEFTE

COUPLE MAXIMUM DE ROTATION ADMISSIBLE

PAR DE ROTACIÓN MÁXIMO ADMISIBILE

TORQUE DE ROTAÇÃO ADMISÍVEL

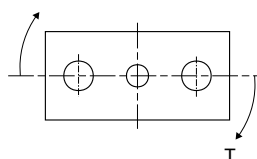

Ø	Stroke (mm)															
	10	20	25	30	40	50	75	100	125	150	175	200	250	300	350	400
12	0,64	0,48	-	0,39	0,32	0,28	0,75	0,63	0,15	0,13	0,12	0,11	0,09	-	-	-
16	1,14	0,9	-	0,74	0,63	0,55	1,23	1,04	0,31	0,27	0,24	0,22	0,18	-	-	-
20	-	1,14	-	1,21	1,07	0,95	1,49	1,25	2,03	1,81	1,63	1,48	0,37	0,32	0,29	0,26
25	-	2,19	-	1,88	1,65	1,47	2,31	1,94	3,15	2,8	2,52	2,3	0,85	0,74	0,66	0,59
32	-	-	6,61	-	-	5,16	4,23	3,59	5,52	4,93	4,45	4,06	1,72	1,50	1,33	1,20

(Unit: N-m)



Scostamento angolare

Anti-roll accuracy

Winkelabweichung

Ecartement angulaire

Desviación angular

Precisão angular anti-giro

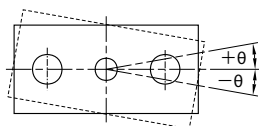

Ø	Scostamento angolare
	Anti-roll Accuracy Ecartement angulaire Winkelabweichung Desviación angular Precisão angular anti-giro θ
12	± 0,09°
16	± 0,08°
20	± 0,08°
25	± 0,07°
32	± 0,07°



Grafico per utilizzo come fermo

Graph for the use as a **STOPPER** (Ø 12 ÷ 32)
 Diagramm für die Verwendung als **STOPPER** (R12 – 32)
 Graphique pour utiliser le vérin en tant que **butée**
 Gráfico para el uso como **parado** (Ø 12 ÷ 32)
 Gráfico para utilização como **stopper** (Ø 12 ÷ 32)

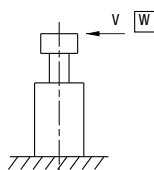

CAPACITÀ DI FERMO
 STOP CAPACITY
 STOPP KAPAZITÄT
 CAPACITE D'ARRÊT
 CAPACIDAD DE PARADA
 CAPACIDADE DE PARADA

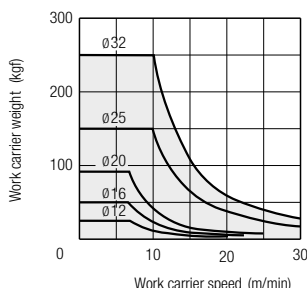

CARICO LATERALE
 LATERAL LOAD
 NORMALE SEITENKRAEFTE
 CHARGE LATERALE
 CARGA LATERAL
 CARGA LATERAL

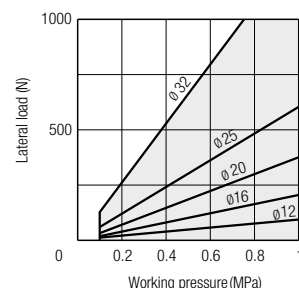

COEFFICIENTE DI CONVERSIONE
 COEFFICIENTS FOR CONVERSION
 UMRECHNUNGSKOEFFIZIENTEN
 COEFFICIENTS DE CONVERSION
 COEFICIENTE DE CONVERSIÓN
 COEFICIENTE DE CONVERSÃO

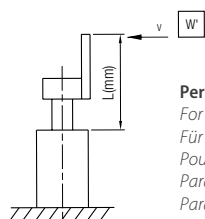

Per attaccare una piastra alla barra di collegamento, scegliere un diametro secondo la formula.

For the use of attaching a plate to the link bar, choose a bore size referring to the formula.
 Für die Befestigung einer Platte an die Verbindungsstange, nehmen Sie für die Bohrdurchmesser Bezug auf die Formel.
 Pour la fixation d'une plaque à la barre de liaison, choisissez un diamètre suivant la formule.
 Para la fijación de una placa sobre la barra, escoger un diámetro referido a la fórmula.
 Para aplicações com placas fixadas no cilindro, escolha o diâmetro de acordo com a fórmula.

SERIES	Ø 12	Ø 16	Ø 20	Ø 25	Ø 32
<i>l</i>	40	42	42	42	44

$$W^1 = \frac{W \cdot l}{L}$$

W: Peso massimo di lavoro come da grafico per la funzione di bloccaggio.

W: The maximum weight of the working load in the above graph for the stopper's capacity.
 W: Höchststarbeitsgewicht gemäss Diagramm für die Verriegelungsfunktion
 W: Charge maximale de travail donnée dans le graphique ci dessus pour la fonction de verrouillage.
 W: Peso máximo para el trabajo realizado en el gráfico superior para la capacidad de paro.
 W: Peso máximo da carga de trabalho no gráfico acima para a capacidade do stopper



Grafico utilizzo sollevamento

Capacity graph for the use as a **LIFTER**
 Diagramm für die Verwendung als **HEBER**
 Graphique pour utilisation de **levage**
 Gráfico para el uso como **elevador**
 Gráfico para uso como **Lifter** (levantamento de cargas)

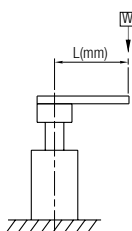

Carico di eccentricità consentito per uso sollevamento alla pressione di 5 bar. Mostra il valore consentito dinamico a L (mm) dal centro della guida.

Allowable eccentricity load for the use as a lifter at supply pressure 5 bar. Show the dynamic allowable value at L (mm) from the centre of the guide rod.
 Zulässige Exzentrizitäts-Last für die Verwendung als Heber bei 5 bar Betriebsdruck. Zeigt den dynamisch zulässigen Wert bei L (mm) von der Mitte der Führungsstange
 Charge excentrée autorisée pour l'utilisation de levage à la pression de 5 bar. Montrez la valeur dynamique autorisée à L (mm) à partir du centre de guidage.
 Carga de excentricidad permitida para el uso como elevador a presión de 5 bar. Muestra el valor dinámico permisible a L (mm) desde el centro del eje de guía.
 Distância máxima da carga com relação ao centro do cilindro para aplicações como lifter com pressão de alimentação de 5 bar. Ver o valor permitido dinâmico em L (mm) a partir do centro da barra de guia.

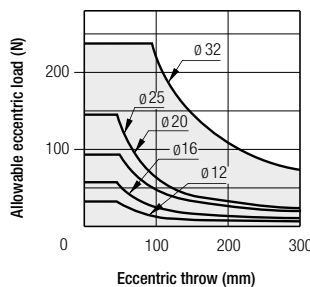

Cuscinetto scorrimento 10-50 st
 Slide Bearing 10-50 st
 Gleitlager 10-50 st
 Guide lisse 10-50 st
 Cojinete 10-50 st
 Deslizamento por esfera 10-50 st

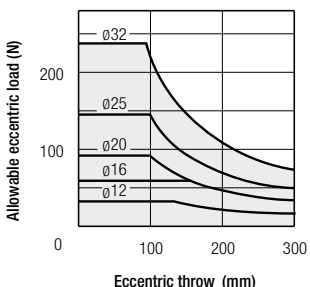

Cuscinetto scorrimento superiore a 51 st
 Slide Bearing over 51 st
 Gleitlager über 51 st
 Guide lisse au delà de 51 st
 Cojinete superior 51 st
 Deslizamento por esfera 51 st