

COMPONENTI DI FISSAGGIO PER CILINDRI ISO 6431 / ISO 15552 / ISO 21287 COMPRESIVI DI VITI

FIXING ACCESSORIES FOR CYLINDERS ISO 6431 - ISO 15552 - ISO 21287 INCLUDING SCREWS
 BEFESTIGUNGSMATERIAL FÜR ZYLINDER ISO 6431 - ISO 15552 - ISO 21287 EINSCHLIESSLICH SCHRAUBEN
 ACCESSOIRES DE FIXATION POUR VÉRINS ISO 6431 - ISO 15552 - ISO 21287 VIS INCLUSES
 COMPONENTES DE FIJACIÓN PARA CILINDROS ISO 6431 - ISO 15552 - ISO 21287 COMPLETOS DE TORNILLOS
 COMPONENTE DE FIXAÇÃO PARA CILINDROS ISO 6431 - ISO 15552 - ISO 21287 INCLUINDO PARAFUSOS

VRL

BLOCCASTELO

PISTON ROD LOCK

FESTELLEINHEIT

UNITÉ DE VERROUILLAGE

UNIDAD DE BLOQUEO

FREIO PARA HASTE

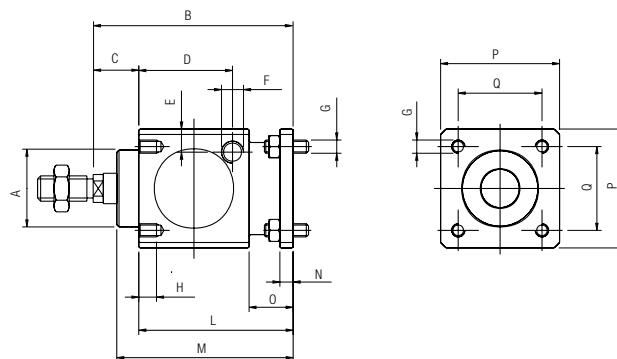

Code	Ø	A	B	C	D	E	F	G	H	L	M	N	O	P	Q
VRL 032	32	30	86	26	33.25	9	1/8"G	M6	8	60	67.5	6	20	47	32.5
VRL 040	40	34.5	100	30	42.5	9	1/8"G	M6	8	70	80	6	20	54	38
VRL 050	50	40	127	37	58	12.5	1/8"G	M8	12	90	100	8	24	65	46.5
VRL 063	63	45	127	37	59	17.5	1/8"G	M8	12	90	100	8	24	75	56.5
VRL 080	80	45	156	46	69	17.5	1/4"G	M10	16	110	120	12	32	95	72
VRL 100	100	55	161	51	69	20	1/4"G	M10	16	110	120	12	32	114	89
VRL 125	125	60	205	65	84.5	19	1/4"G	M12	20	140	156	20	45	138	110

MATERIALE: Alluminio - MATERIAL: Aluminium - MATERIAL: Aluminium - MATÉRIEL: Aluminium - MATERIAL: Alumínio - MATERIAL: Alumínio.

VFT

FLANGIA PER CILINDRO CONTRAPPOSTO

JOINING FLANGE

ZWISCHENFLANSCH

FLASQUE DE JONCTION

BRIDA PARA CILINDRO CONTRAPUESTO

FLANGE DE UNIÃO PARA CILINDROS

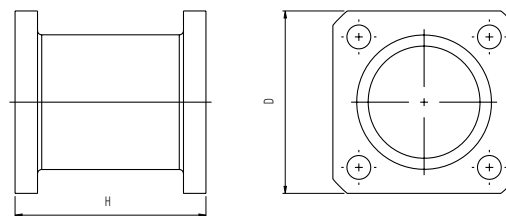

Code	Ø	H	D
VFT 032	32	55	45
VFT 040	40	55	52
VFT 050	50	68	65
VFT 063	63	68	75
VFT 080	80	92	95
VFT 100	100	92	115
VFT 125	125	120	140

MATERIALE: Alluminio - MATERIAL: Aluminium - MATERIAL: Aluminium - MATÉRIEL: Aluminium - MATERIAL: Alumínio - MATERIAL: Alumínio.

QFL

FLANGIA

FLANGE
FLANSCH
BRIDE
BRIDA
FLANGE



Code	Ø	A	B	C	D	E	F	G	H	I	L	M
QFL 012	12-16	18	43	55	18	29	4.5	9	5.5	10	5.4	10
QFL 020	20	22	55	70	22	36	5.5	10	6.6	10	5.4	12
QFL 025	25	26	60	76	26	40	5.5	10	6.6	10	5.4	12

MATERIALE: Acciaio - MATERIAL: Steel - MATERIAL: Stahl - MATÉRIEL: Acier - MATERIAL: Acero - MATERIAL: Aço

VFL

FLANGIA

FLANGE
FLANSCH
BRIDE
BRIDA
FLANGE

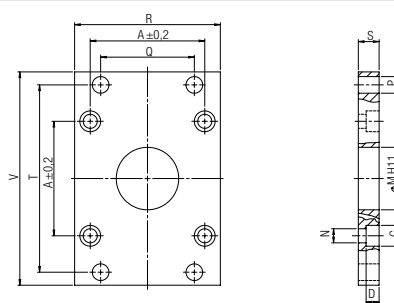

Code ●	Code ■	Ø	Ø M	P	S	D	C	N	A	Q	R	T	V
VFL 032	VFLI 032	32	30	7	10	6,5	10,5	6,5	32,5	32	45	64	80
VFL 040	VFLI 040	40	35	9	10	6,5	10,5	6,5	38	36	52	72	90
VFL 050	VFLI 050	50	40	9	12	8,5	13,5	8,5	46,5	45	65	90	110
VFL 063	VFLI 063	63	45	9	12	8,5	13,5	8,5	56,5	50	75	100	120
VFL 080	VFLI 080	80	45	12	16	10,5	16,5	10,5	72	63	95	126	150
VFL 100	VFLI 100	100	55	14	16	10,5	16,5	10,5	89	75	115	150	170
VFL 125	-	125	60	16	20	12,5	20	13,5	110	90	140	180	205
VFL 160	-	160	65	18	20	16,5	25	17	140	115	180	230	260
VFL 200	-	200	75	22	25	16,5	25	17	175	135	220	270	300
VFL 250	-	250	90	26	25	14,5	33	22	220	165	285	330	400
VFL 320	-	320	110	33	30	15	39	26	270	200	350	400	470

● MATERIALE: Acciaio - MATERIAL: Steel - MATERIAL: Stahl - MATÉRIEL: Acier - MATERIAL: Acero - MATERIAL: Aço
 ■ MATERIALE: Inox - MATERIAL: Inox - MATERIAL: Inox - MATÉRIEL: Inox - MATERIAL: Inox - MATERIAL: Inox

QCP

PIEDINO BASSO

LOW-RISE PEDESTAL
FUSSBEFESTIGUNG
EQUERRE DE FIXATION
PATA
PÉS DE BAIXO PERFIL



Code	Ø	C	B	D	E	F	G	H	I	S	T	R	U	Z
QCP 012	12 - 16	18	18	30	17.5	17.5	4.4	13	13	3	15	9	2	5.5
QCP 020	20	22	22	36	22	22	5.4	16	16	4	17	10	2	6.6
QCP 025	25	26	26	40	22	23	5.4	17	16	4	19	11	2	6.6

MATERIALE: Acciaio - MATERIAL: Steel - MATERIAL: Stahl - MATÉRIEL: Acier - MATERIAL: Acero - MATERIAL: Aço

VCP

PIEDINO BASSO

LOW-RISE PEDESTAL
FUSSBEFESTIGUNG
EQUERRE DE FIXATION
PATA
PÉS DE BAIXO PERFIL



Code ●	Code ■	Ø	B	C	E	F	O	U	V	R	Z	X	Y	H
VCP 032	VCPI 032	32	4	32	45	30	7	24	35	15	7	32.5	15.75	32
VCP 040	VCPI 040	40	4	36	52	30	10	28	36	17.5	7	38	17	36
VCP 050	VCPI 050	50	5	45	65	36	10	32	47	20	9	46.5	21.75	45
VCP 063	VCPI 063	63	5	50	75	35	10	32	45	22.5	9	56.5	21.75	50
VCP 080	VCPI 080	80	6	63	95	47	12	41	55	22.5	11	72	27	63
VCP 100	VCPI 100	100	6	75	115	53	14.5	41	57	27.5	11	89	26.5	71
VCP 125	VCPI 125	125	8	90	140	70	16.5	45	70	30	14	110	35	90
VCP 160	-	160	9	115	180	115	18	60	75	32.5	18	140	45	115
VCP 200	-	200	12	135	220	135	21	70	100	37.5	18	175	47.5	135
VCP 250	-	250	14	165	270	165	26	75	100	45	22	220	55	165

● **MATERIALE: Acciaio** - MATERIAL: Steel - MATERIAL: Stahl - MATÉRIEL: Acier - MATERIAL: Acero - MATERIAL: Aço

■ **MATERIALE: Inox** - MATERIAL: Inox - MATERIAL: Inox - MATÉRIEL: Inox - MATERIAL: Inox - MATERIAL: Inox

VCB

PIEDINO BASSO LARGO

LARGE LOW-RISE PEDESTAL
BEFESTIGUNGSWINKEL
EQUERRE DE FIXATION
PATA BAJA LARGA
PÉS DE BAIXO PERFIL LARGOS



Code	Ø	US	ED	F	AO	B	TR	E	D	FT	NH	R	AU	FB
VCB 032 NE	32	79	45	30	30	5	65	15.75	6.5	15	32	32.5	18	6.5
VCB 040 NE	40	90	55	30	30	5	75	17	6.5	17.5	36	38	18	6.5
VCB 050 NE	50	110	65	35	35	5	90	21.75	8.5	22.5	50	56.5	21	8.5
VCB 063 NE	63	120	75	35	35	5	100	21.75	8.5	22.5	50	56.5	21	8.5
VCB 080 NE	80	153	95	45	45	6	128	26.5	10.5	22.5	63	72	27	10.5
VCB 100 NE	100	178	115	45	45	6	148	27	10.5	27.5	71	89	27	10.5

MATERIALE: Acciaio - MATERIAL: Steel - MATERIAL: Stahl - MATÉRIEL: Acier - MATERIAL: Acero - MATERIAL: Aço

VCF

CERNIERA FEMMINA CON BOCCOLE AUTOLUBRIFICANTI

FEMALE HINGE WITH SELF-LUBRICATING BUSHES

SCHWENKGABELBEFESTIGUNG MIT SELBSTSCHMIERENDER LAGERBUCHSEN

CHAPE DE FIXATION AVEC COUSSINET AUTOLUBRIFIANT

CHARNELA HEMBRA CON COJINETES AUTOLUBRICANTES

FIXAÇÃO OSCILANTE TRASEIRA FÊMEA AUTO-LUBRIFICANTE

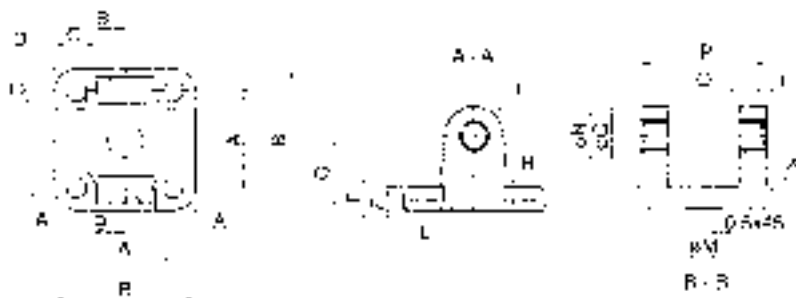

Code ●	Code ■	Ø	B	E	G	T	Z	CM	MR
VCF 032	VCFI 032	32	9	45	10	45	22	26	10
VCF 040	VCFI 040	40	9	52	12	52	25	28	12
VCF 050	VCFI 050	50	11	65	12	60	27	32	12
VCF 063	VCFI 063	63	11	75	16	70	32	40	16
VCF 080	VCFI 080	80	14	95	16	90	36	50	16
VCF 100	VCFI 100	100	14	115	20	110	41	60	20
VCF 125	VCFI 125	125	20	140	25	130	50	70	25
VCF 160	VCFI 160	160	20	180	30	170	55	90	25
VCF 200	VCFI 200	200	25	220	30	170	60	90	25

● **MATERIALE: Alluminio** - MATERIAL: Aluminium - MATERIAL: Aluminium - MATÉRIEL: Aluminium - MATERIAL: Aluminio - MATERIAL: Aluminio

■ **MATERIALE: Inox** - MATERIAL: Inox - MATERIAL: Inox - MATÉRIEL: Inox - MATERIAL: Inox - MATERIAL: Inox

QCM

CERNIERA MASCHIO CON BOCCOLE AUTOLUBRIFICANTI

MALE HINGE WITH SELF-LUBRICATING BUSHES

GABELBEFESTIGUNG MIT SELBSTSCHMIERENDER LAGERBUCHSE

TENON AVEC COUSSINET AUTOLUBRIFIANT

CHARNELA MACHO CON COJINETES AUTOLUBRICANTES

FIXAÇÃO OSCILANTE TRASEIRA MACHO AUTO-LUBRIFICANTE

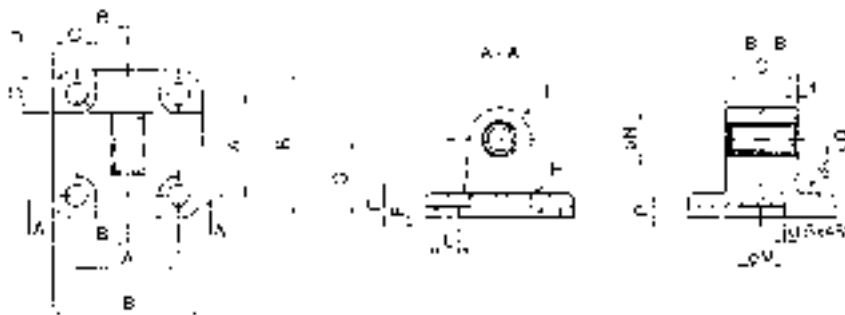

Code	Ø	A	B	C	D	E	F	G	H	I	L	M	N	O	P	Q
QCM 012	12 - 16	18	27	10	4.5	2.6	6	16	2	6	4.5	10	8	12	3	6
QCM 020	20	22	34	11	5	2.6	6	20	2	8	5.5	12	10	16	3	8
QCM 025	25	26	38	11	5	2.6	6	20	2	8	5.5	12	10	16	3	8

MATERIALE: Alluminio - MATERIAL: Aluminium - MATERIAL: Aluminium - MATÉRIEL: Aluminium - MATERIAL: Aluminio - MATERIAL: Aluminio

VCM

CERNIERA MASCHIO

MALE CLEVIS BRACKET

SCHWENKBEFESTIGUNG

TENON À ROTULE

CHARNELA MACHO

FIXAÇÃO OSCILANTE TRASEIRA MACHO

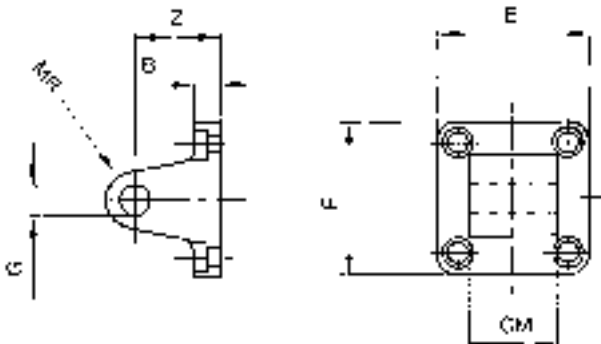

Code ●	Code ■	Code ◆	∅	B	E	G	Z	CM	MR
VCM 032	VCM I 032	VCMZ 032 NE	32	9	45	10	22	26	10
VCM 040	VCM I 040	VCMZ 040 NE	40	9	52	12	25	28	12
VCM 050	VCM I 050	VCMZ 050 NE	50	11	65	12	27	32	12
VCM 063	VCM I 063	VCMZ 063 NE	63	11	75	16	32	40	16
VCM 080	VCM I 080	VCMZ 080 NE	80	14	95	16	36	50	16
VCM 100	VCM I 100	VCMZ 100 NE	100	14	115	20	41	60	20
VCM 125	VCM I 125	VCMZ 125 NE	125	20	140	25	50	70	25
VCM 160	VCM I 160	VCMZ 160 NE	160	20	180	30	55	90	25
VCM 200	VCM I 200	VCMZ 200 NE	200	25	220	30	60	90	25
VCM 250	-	VCMZ 250 NE	250	25	270	40	70	110	40

● **MATERIALE: Alluminio** - MATERIAL: Aluminium - MATERIAL: Aluminium - MATÉRIEL: Aluminium - MATERIAL: Aluminio - MATERIAL: Aluminio

■ **MATERIALE: Inox** - MATERIAL: Inox - MATERIAL: Inox - MATÉRIEL: Inox - MATERIAL: Inox

◆ **MATERIALE: Ferro** - MATERIAL: Iron - MATERIAL: Eisen - MATÉRIEL: Fer - MATERIAL: Hierro - MATERIAL: Ferro

VCH

CERNIERA FEMMINA

FEMALE CLEVIS BRACKET

SCHWENKBEFESTIGUNG MIT SCHLITZ

CHAPE DE FIXATION

CHARNELA HEMBRA

OSCILANTE TRASEIRA FÊMEA

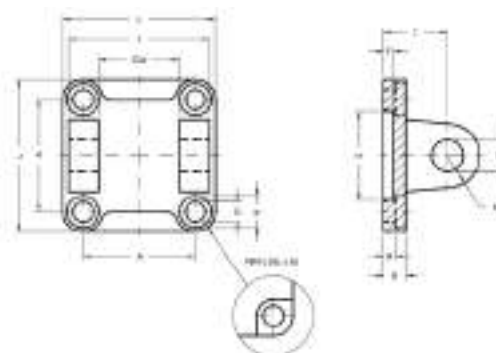

Code	Code ◆	∅	A	L	D	R	N	B	S	F	Z	G	M	CM	T
VCH 032	VCHZ 032 NE	32	32.5	45	6.6	11	5.5	9	30	5	22	10	10	26	45
VCH 040	VCHZ 040 NE	40	38	52	6.6	11	5.5	9	35	5	25	12	12	28	52
VCH 050	VCHZ 050 NE	50	46.5	65	9	15	6.5	11	40	5	27	12	12	32	60
VCH 063	VCHZ 063 NE	63	56.5	75	9	15	6.5	11	45	5	32	16	16	40	70
VCH 080	VCHZ 080 NE	80	72	95	11	18	10	14	45	5	36	16	16	50	90
VCH 100	VCHZ 100 NE	100	89	115	11	18	10	14	55	5	41	20	20	60	110
VCH 125	VCHZ 125 NE	125	110	140	14	20	10	20	60	7	50	25	25	70	130
VCH 160	VCHZ 160 NE	160	140	180	18	26	10	20	65	7	55	30	25	90	170
VCH 200	VCHZ 200 NE	200	175	220	18	26	11	25	75	7	60	30	25	90	170
VCH 250	VCHZ 250 NE	250	220	270	22	33	11	25	90	-	70	40	40	110	200

● **MATERIALE: Alluminio** - MATERIAL: Aluminium - MATERIAL: Aluminium - MATÉRIEL: Aluminium - MATERIAL: Aluminio - MATERIAL: Aluminio

◆ **MATERIALE: Ferro** - MATERIAL: Iron - MATERIAL: Eisen - MATÉRIEL: Fer - MATERIAL: Hierro - MATERIAL: Ferro

VCD

CERNIERA FEMMINA STRETTA PER ARTICOLAZIONE A SQUADRA CON TESTINA SNODATA DIN648K

NARROW FEMALE HINGE FOR SQUARE JOINT WITH ARTICULATED HEAD DIN648K

SCHWENKBEFESTIGUNG MIT SCHLITZ FÜR GELENKKOPF NACH DIN 648K

CHAPE À ROTULE SELON DIN 648K

CHARNELA HEMBRA ESTRECHA PARA ARTICULACIÓN A ESCUADRA CON RÓTULA DIN648K

OSCILANTE TRASEIRA FÊMEA ESTREITA PARA JUNTA QUADRADA ARTICULADA PADRÃO DIN648K

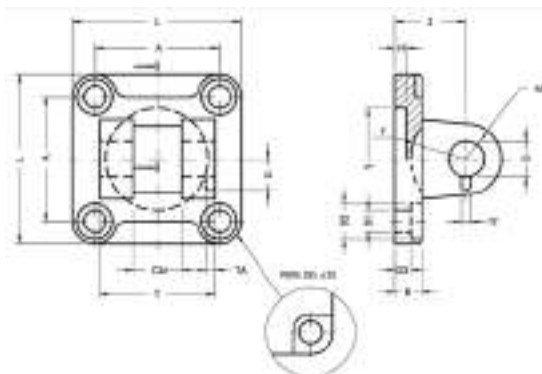

Code ●	Code ◆	Ø	L	T	CM	A	Z	H	B	D3	S	G	MR	D1	D2	TA	TZ	LI	F
VCD 032	VCDZ 032 NE	32	45	34	14	32.5	22	5	9	5.5	30	10	10	6.6	11	3	3.3	11.5	17
VCD 040	VCDZ 040 NE	40	52	40	16	38	25	5	9	5.5	35	12	12	6.6	11	4	4.3	12	20
VCD 050	VCDZ 050 NE	50	65	45	21	46.5	27	5	11	6.5	40	16	14	9	15	4	4.3	14	22
VCD 063	VCDZ 063 NE	63	75	51	21	56.5	32	5	11	6.5	45	16	18	9	15	4	4.3	14	25
VCD 080	VCDZ 080 NE	80	95	65	25	72	36	5	14	10	45	20	20	11	18	4	4.3	16	30
VCD 100	VCDZ 100 NE	100	115	75	25	89	41	5	14	10	55	20	22	11	18	4	6.3	16	32
VCD 125	VCDZ 125 NE	125	140	97	37	110	50	7	20	10	60	30	25	14	20	6	6.3	24	42
VCD 160	-	160	180	122	43	140	55	7	20	10	65	35	30	18	26	6	6.3	26.5	46
VCD 200	-	200	220	122	43	175	60	7	25	11	75	35	30	18	26	6	6.3	26.5	49

● MATERIALE: Alluminio - MATERIAL: Aluminium - MATERIAL: Aluminium - MATÉRIEL: Aluminium - MATERIAL: Aluminio - MATERIAL: Alumínio

◆ MATERIALE: Ferro - MATERIAL: Iron - MATERIAL: Eisen - MATÉRIEL: Fer - MATERIAL: Hierro - MATERIAL: Ferro

VPS

PERNO ANTIROTAZIONE PER CERNIERA FEMMINA STRETTA VCD

PIN ANTI-ROTATION FOR NARROW FEMALE HINGE VCD

VERDREHSICHERUNG FÜR SCHWENKBEFESTIGUNG VCD

GOIJONS ANTI-ROTATION POUR CHAPE VCD

PERNO ANTIROTACIÓN PARA CHARNELA HEMBRA ESTRECHA VCD

PINO ANTI-ROTAÇÃO PARA OSCILANTE FÊMEA ESTREITA VCD



Code ●	Code ■	Ø	A	C	D	E	F	G	H	L	B
VPS 032	VPSI 032	32	3	32.5	1.1	10	9.6	4	41	14	4.5
VPS 040	VPSI 040	40	4	38	1.1	12	11.5	4	48	16	6
VPS 050	VPSI 050	50	4	43	1.1	16	15.2	5	60	20	6
VPS 063	VPSI 063	63	4	49	1.1	16	15.2	5	60	20	6
VPS 080	VPSI 080	80	4	63	1.3	20	19	6	75	24	6
VPS 100	VPSI 100	100	4	73	1.3	20	19	6	85	24	6
VPS 125	VPSI 125	125	6	94	1.6	30	28.6	7	110	36	9
VPS 160	-	160 - 200	6	119	1.6	35	33	7	135	41	9

● MATERIALE: Alluminio - MATERIAL: Aluminium - MATERIAL: Aluminium - MATÉRIEL: Aluminium - MATERIAL: Aluminio - MATERIAL: Alumínio

■ MATERIALE: Inox - MATERIAL: Inox - MATERIAL: Inox - MATÉRIEL: Inox - MATERIAL: Inox - MATERIAL: Inox

VCS

CERNIERA MASCHIO STRETTA CON TESTINA SNODATA DIN648K

NARROW MALE HINGE WITH ARTICULATED HEAD DIN648K

SCHWENKBEFESTIGUNG MIT SCHMALEM GELENKKOPF NACH DIN 648K

TENON AVEC TÊTE ARTICULÉE SELON DIN 648K

CHARNELA MACHO ESTRECHA CON RÓTULA DIN648K

OSCILANTE TRASEIRA MACHO ARTICULADA PADRÃO DIN648K

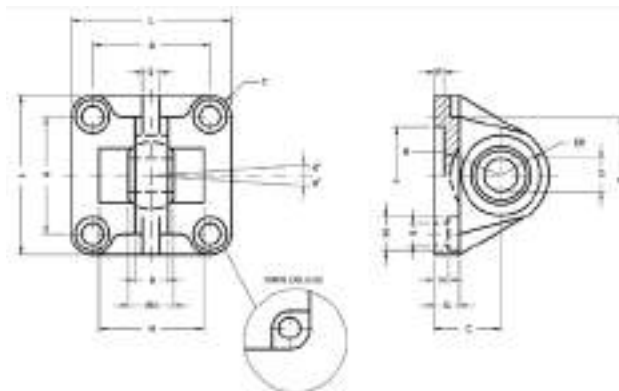

Code ●	Code ■	Code ◆	∅	A	B	C	D	EN	ER	F	G	E	L	M	N	P	H	R	S	Z	T
VCS 032	VCSI 032	VCSZ 032 NE	32	32.5	10.5	22	10	14	16	30	9	6.6	45	11	5.5	5	-	-	4	32.5	6.25
VCS 040	VCSI 040	VCSZ 040 NE	40	38	12	25	12	16	19	35	9	6.6	52	11	5.5	5	-	-	6	39	7
VCS 050	VCSI 050	VCSZ 050 NE	50	46.5	15	27	16	21	21	40	11	9	65	15	6.5	5	51	18	8	47	9.25
VCS 063	VCSI 063	VCSZ 063 NE	63	56.5	15	32	16	21	24	45	11	9	75	15	6.5	5	-	-	8	52	9.25
VCS 080	VCSI 080	VCSZ 080 NE	80	72	18	36	20	25	28.5	45	14	11	95	18	10	5	72	24	10	67	11.5
VCS 100	VCSI 100	VCSZ 100 NE	100	89	18	41	20	25	30	55	14	11	115	18	10	8	-	-	10	77	13
VCS 125	VCSI 125	VCSZ 125 NE	125	110	25	50	30	37	40	60	20	13.5	140	20	10	7	-	-	13	98	15
VCS 160	-	-	160	140	28	55	35	43	45	65	20	18	180	26	10	7	-	-	14	130	20
VCS 200	-	-	200	175	28	60	35	43	48	75	25	18	220	26	11	7	-	-	14	155	22.5

● **MATERIALE: Alluminio** - MATERIAL: Aluminium - MATERIAL: Aluminium - MATÉRIEL: Aluminium - MATERIAL: Aluminio - MATERIAL: Alumínio

■ **MATERIALE: Inox** - MATERIAL: Inox - MATERIAL: Inox - MATÉRIEL: Inox - MATERIAL: Inox - MATERIAL: Inox

◆ **MATERIALE: Ferro** - MATERIAL: Iron - MATERIAL: Eisen - MATÉRIEL: Fer - MATERIAL: Hierro - MATERIAL: Ferro

VADZ

ARTICOLAZIONE A SQUADRA CON TESTINA SNODATA DIN648K

SQUADRE JOINT WITH ARTICULATED HEAD DIN648K

SCHWENKBEFESTIGUNG MIT SCHMALEM GELENKKOPF NACH DIN 648K

TENON AVEC TÊTE ARTICULÉE SELON DIN 648K

ARTICULACIÓN A ESCUADRA CON RÓTULA DIN648K

JUNTA QUADRADA ARTICULADA PADRÃO DIN648K

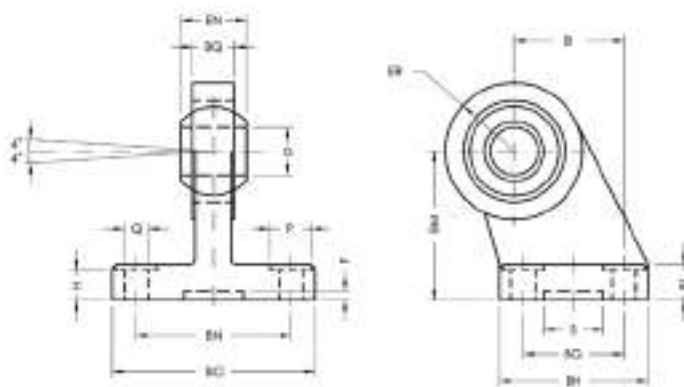

Code	∅	Q	P	BG	BH	BI	BL	BM	BN	BO	EN	ER	BQ	D	H	S	F
VADZ 032 NE	32	6.6	11	18	31	21	10	32	38	51	14	15	10.5	10	8.5	20	3
VADZ 040 NE	40	6.6	11	22	35	24	10	36	41	54	16	18	12	12	8.5	20	3
VADZ 050 NE	50	9	15	30	45	33	12	45	50	65	21	20	15	16	10.5	20	3
VADZ 063 NE	63	9	15	35	50	37	12	50	52	67	21	23	15	16	10.5	20	3
VADZ 080 NE	80	11	18	40	60	47	14	63	66	86	25	27	18	20	11.5	20	3
VADZ 100 NE	100	11	18	50	70	55	15	71	76	96	25	30	18	20	12.5	20	3
VADZ 125 NE	125	13.5	20	60	90	70	20	90	94	124	37	40	25	30	17	20	3

MATERIALE: Acciaio - MATERIAL: Steel - MATERIAL: Stahl - MATÉRIEL: Acier - MATERIAL: Acero - MATERIAL: Aço

TRATTAMENTO: Cataforesi nera - TREATMENT: Black Cataphoresis - BEHANDLUNG: Geschwärzt - TRAITEMENT: Noircissage

TRATAMIENTO: Cataforesis Negra - TRATAMENTO: Cataforesis Negra

XCN

CERNIERA INTERMEDIA

INTERMEDIATE HINGE
MITTELSCHWENKZAPFENBEFESTIGUNG
TOURILLON MÂLE
CHARNELA INTERMEDIA
OSILANTE INTERMEDIÁRIA

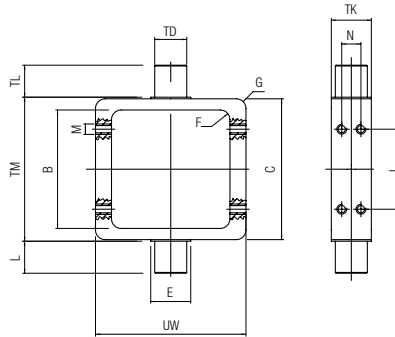

Code	Ø	UW	B	C	TD	E	F	G	TK	I	TL	M	N	TM
XCN 032	32	65	45	50	12	-	5	4	20	28	12	M5	7	50
XCN 040	40	75	53	62	16	20	5	5	20	32	16	M5	8	63
XCN 050	50	90	64	74	16	20	6	6	20	40	16	M6	8	75
XCN 063	63	100	74	88	20	25	6	6	25	50	20	M6	12	90
XCN 080	80	130	93	109	20	25	7	7	25	64	20	M8	12	110
XCN 100	100	140	110	130	25	30	8	8	30	80	25	M8	15	132
XCN 125	125	150	134	155	25	30	8	8	30	100	25	M10	15	160

MATERIALE: Acciaio - MATERIAL: Steel - MATERIAL: Stahl - MATÉRIEL: Acier - MATERIAL: Acero - MATERIAL: Aço

VCNT

CERNIERA INTERMEDIA

INTERMEDIATE HINGE
MITTELSCHWENKZAPFENBEFESTIGUNG
TOURILLON MÂLE
CHARNELA INTERMEDIA
OSILANTE INTERMEDIÁRIA

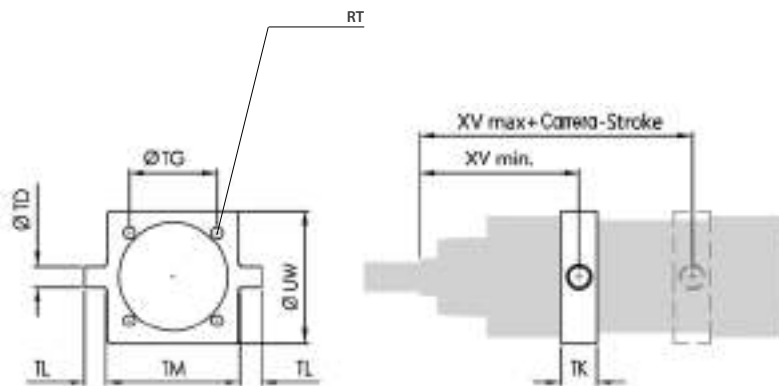

Code	Ø	TD	TG	TK	TL	TM	UW	XV min	XV max	RT
VCNT 032	32	12	32.5	15	12	50	46	61.5	84.5	M6
VCNT 040	40	16	38	20	16	63	59	71.5	93.5	M6
VCNT 050	50	16	46.5	20	16	75	69	78.5	101.5	M8
VCNT 063	63	20	56.5	25	20	90	84	84.5	110.5	M8
VCNT 080	80	20	72	25	20	110	102	94.5	125.5	M10
VCNT 100	100	25	89	30	25	132	125	107	133	M10
VCNT 125	125	25	110	32	25	160	155	126	163	M12
VCNT 160	160	32	140	40	32	200	190	149	191	M16
VCNT 200	200	32	175	40	32	250	240	164	206	M16
VCNT 250	250	40	220	50	40	320	296	187	223	M20

MATERIALE: Acciaio - MATERIAL: Steel - MATERIAL: Stahl - MATÉRIEL: Acier - MATERIAL: Acero - MATERIAL: Aço

VCNL

CERNIERA INTERMEDIA PER TIRANTI LISCI

INTERMEDIATE HINGE FOR SMOOTH TIE-RODS
 ZWISCHENSCHARNIER FÜR GLATTE ZUGSTANGEN
 CHARNIERE INTERMEDIAIRE POUR TIRANTS LISSES
 CHARNELA INTERMEDIA PARA TIRANTES LISOS
 MUNHÃO CENTRAL PARA TIRANTES LISOS

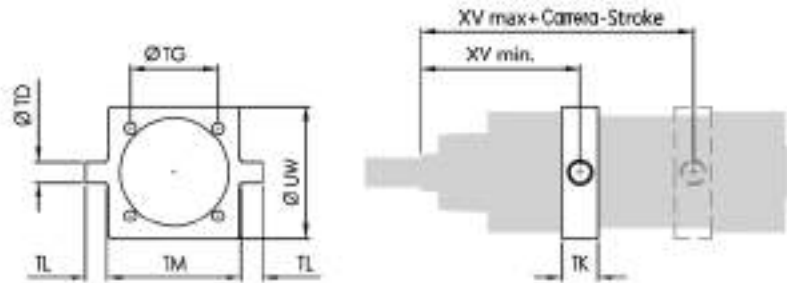

Code	Ø	TD	TG	TK	TL	TM	UW	XV min	XV max
VCNL 032	32	12	32.5	15	12	50	46	61.5	84.5
VCNL 040	40	16	38	20	16	63	59	71.5	93.5
VCNL 050	50	16	46.5	20	16	75	69	78.5	101.5
VCNL 063	63	20	56.5	25	20	90	84	84.5	110.5
VCNL 080	80	20	72	25	20	110	102	94.5	125.5
VCNL 100	100	25	89	30	25	132	125	107	133
VCNL 125	125	25	110	32	25	160	155	126	163
VCNL 160	160	32	140	40	32	200	190	149	191
VCNL 200	200	32	175	40	32	250	240	164	206

MATERIALE: Acciaio - MATERIAL: Steel - MATERIAL: Stahl - MATÉRIEL: Acier - MATERIAL: Acero - MATERIAL: Aço

VSI

SUPPORTO CERNIERA INTERMEDIA

SUPPORT FOR INTERMEDIATE HINGE
 GEGENLAGER FÜR MITTELSCHWENKZAPFENBEFESTIGUNG
 SUPPORT DE TOURILLON
 SOPORTE PARA CHARNELA INTERMEDIA
 SUPORTE PARA OSCILANTE INTERMEDIÁRIA

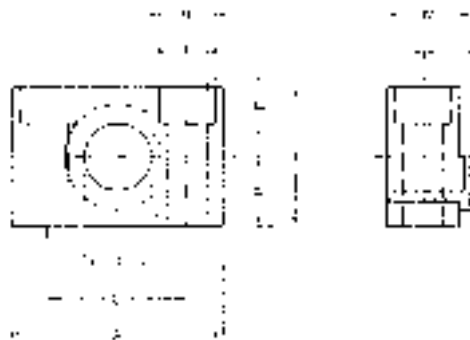

Code	Ø	A	M	R	P	C	S	L	U	T	E
VSI 032	32	46	18	30	15	32	12	10.5	11	6.6	7
VSI 040	40 - 50	55	21	36	18	36	16	12	15	9	9
VSI 063	63 - 80	65	23	40	20	42	20	13	18	11	11
VSI 100	100 - 125	75	28.5	50	25	50	25	16	20	14	13
VSI 160	160 - 200	92	40	60	30	60	32	22.5	26	18	17
VSI 250	250	140	56	70	35	90	40	31	33	22	20

MATERIALE: Acciaio - MATERIAL: Steel - MATERIAL: Stahl - MATÉRIEL: Acier - MATERIAL: Acero - MATERIAL: Aço

VAS

ARTICOLAZIONE A SQUADRA

SQUARE JOINT

LAGERBOCK

TENON AVEC PALIER

ARTICULACIÓN A ESCUADRA

ARTICULAÇÃO QUADRADA

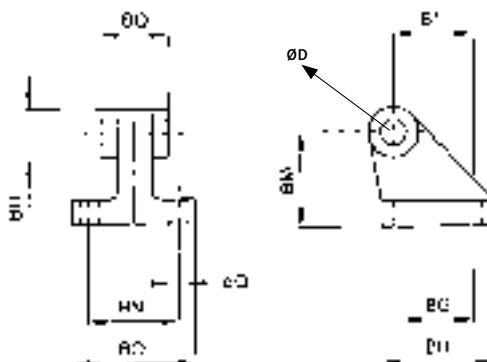

Code ●	Code ■	Ø	Q	BG	BH	BI	BM	BN	BO	BQ	BR	ØD
VAS 032	VASI 032	32	6.6	18	31	21	32	38	51	26	20	10
VAS 040	VASI 040	40	6.6	22	35	24	36	41	54	28	22	12
VAS 050	VASI 050	50	9	30	45	33	45	50	65	32	26	12
VAS 063	VASI 063	63	9	35	50	37	50	52	67	40	30	16
VAS 080	VASI 080	80	11	40	60	47	63	66	86	50	30	16
VAS 100	VASI 100	100	11	50	70	55	71	76	96	60	38	20
VAS 125	VASI 125	125	14	60	90	70	90	94	124	70	45	25
VAS 160	-	160	14	88	126	97	115	118	156	90	63	30
VAS 200	-	200	18	90	130	105	135	122	162	90	63	30

● **MATERIALE: Alluminio** - MATERIAL: Aluminium - MATERIAL: Aluminium - MATÉRIEL: Aluminium - MATERIAL: Aluminio - MATERIAL: Alumínio

■ **MATERIALE: Inox** - MATERIAL: Inox - MATERIAL: Inox - MATÉRIEL: Inox - MATERIAL: Inox - MATERIAL: Inox

VPE

PERNO PER CERNIERA CON SEEGER

PIN WITH SEEGER

BOLZEN INKL. SEEGERRINGE

AXE AVEC ANNEAUX CIRCLIPS

PERNO PARA CHARNELA CON SEEGER

PINO COM ANEL ELÁSTICO TIPO SEEGER

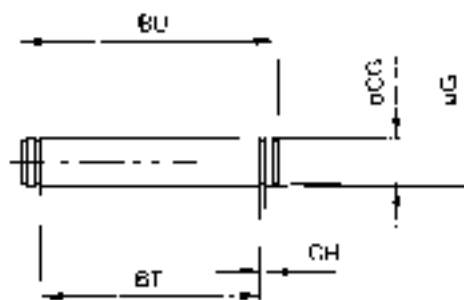

Code ●	Code ■	Ø	G	BT	BU	CG	CH
VPE 032	VPEI 032	32	10	46	53	9.6	1.1
VPE 040	VPEI 040	40	12	53	60	11.5	1.1
VPE 050	VPEI 050	50	12	61	68	11.5	1.1
VPE 063	VPEI 063	63	16	71	78	15.2	1.1
VPE 080	VPEI 080	80	16	91	98	15.2	1.1
VPE 100	VPEI 100	100	20	111	118	19	1.3
VPE 125	VPEI 125	125	25	132	139	23.9	1.3
VPE 160	VPEI 160	160 - 200	30	171.5	178	28.6	1.6
VPE 250	-	250	40	202	211	37.5	1.85
VPE 320	-	320	45	222	236	42.5	1.85

● **MATERIALE: Acciaio** - MATERIAL: Steel - MATERIAL: Stahl - MATÉRIEL: Acier - MATERIAL: Acero - MATERIAL: Aço

■ **MATERIALE: Inox** - MATERIAL: Inox - MATERIAL: Inox - MATÉRIEL: Inox - MATERIAL: Inox - MATERIAL: Inox

FC

FORCELLA CON CLIPS

YOKE WITH LOCABLE PIN
 GABELKOPF MIT SICHERUNGSCLIP
 CHAPE DE TIGE AVEC CLIP DE SÉCURITÉ
 HORQUILLA CON CLIPS
 GARFO COM CLIPS

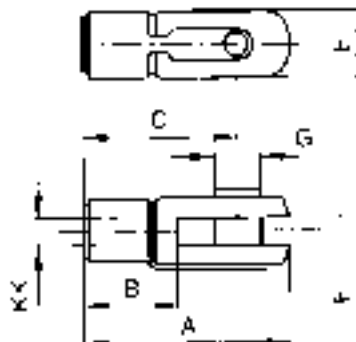

Code ●	Code ■	KK	A	B	C	E	F	G
FC 020	* FCI 020	M8x1.25	42	16	32	16	8	8
FC 025	* FCI 025	M10x1.25	52	20	40	20	10	10
FC 040	* FCI 040	M12x1.25	62	24	48	24	12	12
FC 050	* FCI 050	M16x1.5	83	32	64	32	16	16
FC 080	* FCI 080	M20x1.5	105	40	80	40	20	20
* FC 125	* FCI 125	M27x2	148	56	110	55	30	30
* FC 160	* FCI 160	M36x2	188	72	144	70	35	35
* FC 250	-	M42x2	232	84	168	85	42	42
* FC 320	-	M48x2	265	96	192	96	50	50

● **MATERIALE: Acciaio** - MATERIAL: Steel - MATERIAL: Stahl - MATÉRIEL: Acier - MATERIAL: Acero - MATERIAL: Aço

■ **MATERIALE: Inox** - MATERIAL: Inox - MATERIAL: Inox - MATÉRIEL: Inox - MATERIAL: Inox - MATERIAL: Inox

* **Con Perno e Seeger** - With pin and seeger - Mit Bolzen inkl. Seegering - Axe et annaux circlips inclus - Con perno y seeger - Com Pino e Seeger.

TF

TESTE DI BIELLA AUTOLUBRIFICANTI

ROD ENDS SELF-LUBRICATING
 GELENKKOPF SELBSTSCHMIEREND
 OEUILLÉTON A ROTULE AUTOLUBRIFIANT
 RÓTULA AUTOLUBRICANTE
 RÓTULA ESFÉRICA AUTO-LUBRIFICANTE

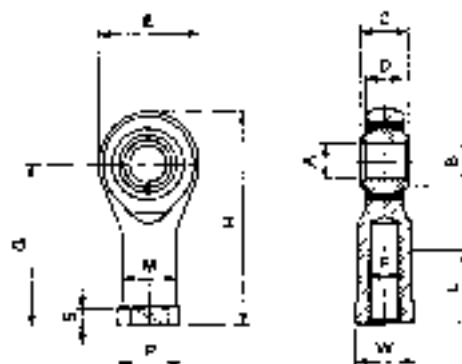

- | | |
|-------------------|------------------|
| D Dinamico | S Statico |
| Dynamic | Static |
| Dinamisch | Statisch |
| Dynamique | Statique |
| Dinámica | Estática |
| Dinâmico | Estático |

Code	F	A	B	C	Ø Sfera Sphere Kugel Sphère Esfera	D	E	G	H	L	M	P	S	W	Carico radiale Radial load Radiallast Charge radiale Carga radial Carga radial		Peso Weight Gewicht Poids Peso Peso
															D	S	
		0 H7	0	0 -0.13		± 0.13	± 0.5	± 0.5		± 0.7	± 0.7	± 0.5	± 0.7	± 0.25	kg	kg	g
TF 020	M8x1,25	8	10.4	12	15.88	9	24	36	48	12	12.5	16	5	14	780	1.900	36
TF 025	M10x1,25	10	12.9	14	19.05	11.5	30	43	58	15	15	19	6.5	16	1.200	3.100	88
TF 040	M12x1,25	12	15.4	16	22.23	12.5	34	50	67	18	17.5	22	6.5	18	1.400	3.700	120
TF 050	M16x1,5	16	19.3	21	28.58	15.5	42	64	85	24	22	27	8	24	2.500	6.300	240
TF 080	M20x1,5	20	24.4	25	34.93	18.5	50	77	102	30	27.5	34	10	30	3.700	8.300	430
TF 125/30	M27x2	30	34.8	37	-	25	70	110	146	51	40	50	15	41	-	10.800	1.120
TF 160	M36x2	35	-	43	-	-	-	125	-	56	-	58	-	-	-	-	1.600
TF 250	M42x2	40	-	49	-	-	-	142	-	60	-	65	-	-	-	-	2.800
TF 320	M48x2	50	-	60	-	-	-	162	-	65	-	75	-	-	-	-	5.000

MATERIALE: Acciaio - MATERIAL: Steel - MATERIAL: Stahl - MATÉRIEL: Acier - MATERIAL: Acero - MATERIAL: Aço

TS

SNODO ASSIALE

SNODABLE YOKE
AXIAL VERBINDUNG
ARTICULATION AXIALE
HORQUILLA AUTOALINEANTE
JUNTA FLUTUANTE

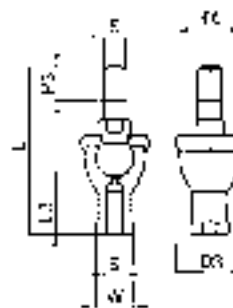

Code	S	L	L3	W	P3	D3	α°	(kN)
TS 020	M8x1.25	65	16	14	12	20	30°	3,5
TS 025	M10x1.25	74.5	18	17	15	28	30°	5
TS 040	M12x1.25	84	20	19	17	32	30°	6,7
TS 050	M16x1.5	112	27	22	23	40	22°	7,8
TS 080	M20x1.5	133	38	30	25	45	15°	10

MATERIALE: Acciaio - MATERIAL: Steel - MATERIAL: Stahl - MATÉRIEL: Acier - MATERIAL: Acero - MATERIAL: Aço

TM

TESTA DI BIELLA MASCHIO

MALE ROD ENDS
GELENKKOPF SELBSTSCHMIEREND
OEILLETON A ROTULE AUTOLUBRIFIANT
RÓTULA MACHO
RÓTULA ESFÉRICA MACHO

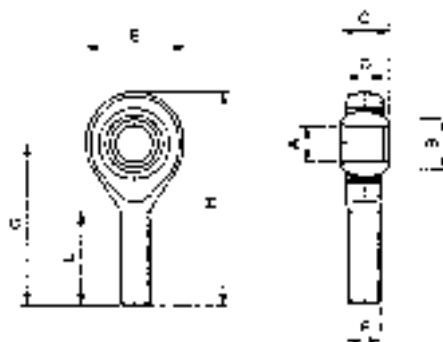

D : Dinamico
Dynamic
Dynamisch
Dynamique
Dinámica
Dinámico

S : Statico
Static
Statis
Statique
Estática
Estático

Code	F	A	B	C	Ø Sfera Sphere Kugel Sphère Esfera	D	E	G	H	L	Carico radiale Radial load Radiallast Charge radiale Carga radial Carga radial		Peso Weight Gewicht Poids Peso Peso
											D	S	
		0 H7	0	0 -0.13		± 0.13	± 0.5	± 0.5		± 0.7	kg	kg	g
TM 020	M5x0.8	5	7.5	8	11.11	7.5	18	33	42	19	430	1000	13
TM 032	M6x1	6	8.9	9	12.7	7.5	20	36	46	21	470	1100	15
TM 050	M8x1.25	8	10.4	12	15.88	9.5	24	42	54	25	780	1900	34
TM 080	M10x1.5	10	12.9	14	19.05	11.5	30	48	63	28	1200	3100	70
TM 100	M12x1.75	12	15.4	16	22.23	12.5	34	54	71	32	1400	3700	110

MATERIALE: Acciaio - MATERIAL: Steel - MATERIAL: Stahl - MATÉRIEL: Acier - MATERIAL: Acero - MATERIAL: Aço

DA

DADO PER STELI

NUT FOR RODS
MUTTER FÜR KOLBENSTANGE
ECROU POUR TIGE
TUERCA PARA VÁSTAGO
PORCA PARA HASTE

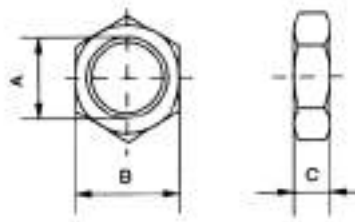

Code	A	B	C
0DA00 00 51 C3 ZI	M8x1.25	13	6.5
0DA00 00 51 C9 ZI	M10x1.25	17	8
0DA00 00 51 D5 ZI	M12x1.25	19	7
0DA00 00 51 E3 ZI	M16x1.5	22	6
0DA00 00 51 F2 ZI	M20x1.5	30	9
0DA00 00 51 G8 ZI	M27x2	41	12
EDA00 00 51 I6 ZI	M36x2	55	14
EDA00 00 51 L0 ZI	M42x2	65	20
EDA00 00 51 DG ZI	M48x2	75	24

MATERIALE: Acciaio - MATERIAL: Steel - MATERIAL: Stahl - MATÉRIEL: Acier - MATERIAL: Acero - MATERIAL: Aço