

UNITÀ DI GUIDA

GUIDE UNITS
FÜHRUNGSEINHEITEN
UNITÉS DE GUIDAGE
UNIDADES DE GUIADO
GUIA PARA CILINDROS



CARATTERISTICHE TECNICHE

TECHNICAL CHARACTERISTICS
TECHNISCHE ANGABEN
CARACTÉRISTIQUES TECHNIQUES
CARACTERÍSTICAS TÉCNICAS
CARACTERÍSTICAS TÉCNICAS



1907/2006
REACH ✓

2011/65/CE
RoHS ✓

PED
2014/68/UE

SILICON
FREE

ISO 6431 VDMA
(from 32 to 100)

ISO 6432
(from 20 to 25)

ISO 15552
(from 32 to 100)



Alesaggi

Bores

Durchmesser

Diamètres

Diámetros

Diámetros

12 - 20 - 25 - 32 - 40 - 50 - 63 - 80 mm



Corse

Strokes

Hub

Courses

Carreras

Cursos

from 50 to 500 mm



Tabella dei codici di ordinazione

Ordering codes

Bestellschlüssel

Code de commande

Tabla de codificación para pedidos

Tabela de codificação para compra

SERIE	Ø mm	Corsa Stroke Hub Course Carrera Curso mm
-------	---------	--

M L C U B

0 1 2

0 0 5 0

- ◆ **MLCUB** Unita' di guida ad "u" con bussole in bronzo
Guide unit "u" with self lubricating sintered bronze
Führungseinheiten "u" mit gleitlager aus bronze selbstschmierend
Unités de guidage "u" avec paliers en bronze autolubrifiants
Unidad de guiado tipo "u" con cojinetes de bronce
Guia em "u" com bucha de bronze
- **MLCHB** Unita' di guida ad "h" con bussole in bronzo
Guide unit "h" with self lubricating sintered bronze
Führungseinheiten "h" mit gleitlager aus bronze selbstschmierend
Unités de guidage "h" avec paliers en bronze autolubrifiants
Unidad de guiado tipo "h" con cojinetes de bronce
Guia em "h" com bucha de bronze
- **MLCHC** Unita' di guida ad "h" con cuscinetti a ricircolo di sfere
Guide unit "h" with recirculating ball sleeves
Führungseinheiten "h" mit kugellagerführungen
Unités de guidage "h" avec douilles à billes
Unidad de guiado tipo "h" con cojinetes de bolas
Guia em "h" com rolamento de esferas recirculante
- **VLCUB** Unita' di guida ad "u" con bussole in bronzo
Guide unit "u" with self lubricating sintered bronze
Führungseinheiten "u" mit kugellagerführungen
Unités de guidage "u" avec paliers en bronze autolubrifiants
Unidad de guiado tipo "u" con cojinetes de bronce
Guia em "u" com bucha de brone
- **VLCHB** Unita' di guida ad "h" con bussole in bronzo
Guide unit "h" with self lubricating sintered bronze
Führungseinheiten "h" mit gleitlager aus bronze selbstschmierend
Unités de guidage "h" avec paliers en bronze autolubrifiants
Unidad de guiado tipo "h" con cojinetes de bronce
Guia em "h" com bucha de bronze
- **VLCHC** Unita' di guida ad "h" con cuscinetti a ricircolo di sfere
Guide unit "h" with recirculating ball sleeves
Führungseinheiten "h" mit kugellagerführungen
Unités de guidage "h" avec douilles à billes
Unidad de guiado tipo "h" con cojinetes de bolas
Guia em "h" com rolament de esferas recirculantes

012
020
025
032
040
050
063
080
100

0050
0100
0160
0200
0250
0320
0400
0500

A richiesta corse intermedie o superiori.
Intermediate or higher strokes are available upon request.
Auf Anfrage Zwischenhübe.
Autres courses sur demande.
Bajo demanda carreras intermedias o superiores.
Cursos intermedíarios ou superiores sob encomenda.

Ø (mm)	Corse - Strokes - Hub - Courses - Carreras - Cursos							
	mm							
	50	100	160	200	250	320	400	500
12 - 16	◆○	◆○	◆○	◆○	○			
20	◆○	◆○	◆○	◆○	○			
25	◆○	◆○	◆○	◆○	○			
32	●	●	●	●	●	●	●	●
40	●	●	●	●	●	●	●	●
50	●	●	●	●	●	●	●	●
63	●	●	●	●	●	●	●	●
80	●	●	●	●	●	●	●	●
100	●	●	●	●	●	●	●	●

GRAFICI UNITÀ DI GUIDA

CHARTS GUIDE UNITS

GRAFIKEN DER FÜHRUNGSEINHEIT

GRAPHIQUES DE L'UNITÉ DE GUIDAGE

GRÁFICO UNIDADES DE GUIADO

GRÁFICOS DAS GUIAS

N	mm
Carico massimo F	Corsa
Max load	Stroke
Max. Belastung	Hub
Max. Charge	Course
Max carga	Carrera
Carga máxima	Curso

Art. MLCHB

Unità di guida con bussole in bronzo

Guide units with self lubricating sintered bush

Führungseinheiten mit Gleitlager aus Bronze

Unités de guidage avec palier en bronze

Unidad de guiado con cojinetes de bronce

Guias com bucha de bronze

- Ø20 - Ø25
- Ø12 - Ø16

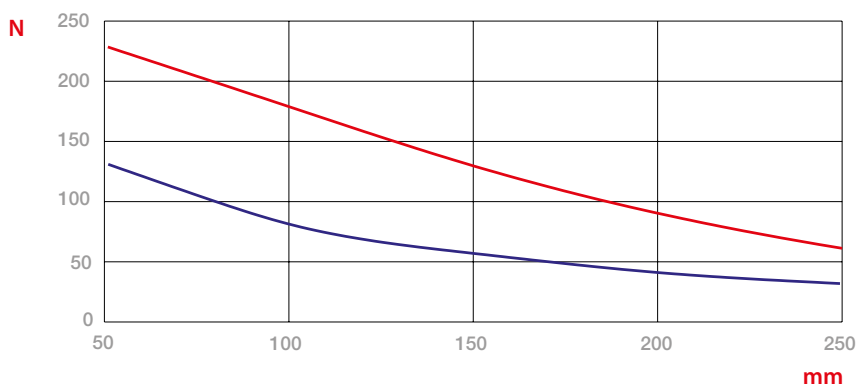

Art. VLCHB

Unità di guida con bussole in bronzo

Guide units with self lubricating sintered bush

Führungseinheiten mit Gleitlager aus Bronze

Unités de guidage avec palier en bronze

Unidad de guiado con cojinetes de bronce

Guias com bucha de bronze

- Ø80 - Ø100
- Ø63
- Ø50
- Ø40
- Ø32

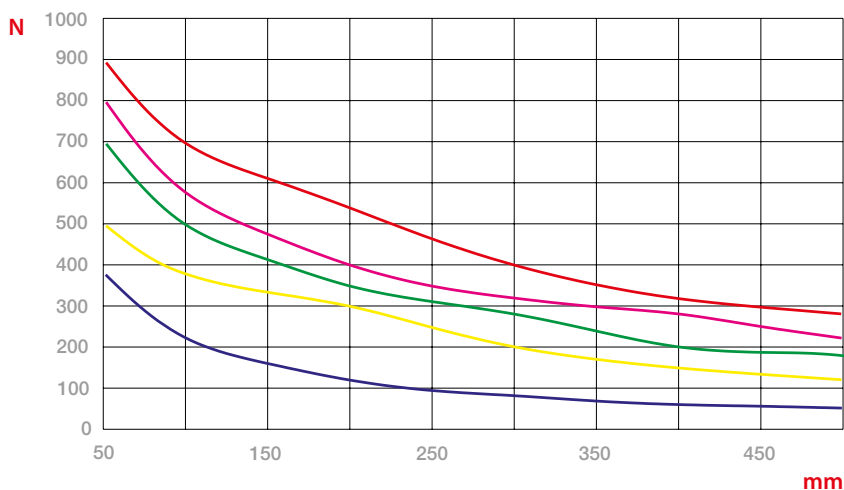

Art. MLCHC

Unità di guida con cuscinetti a ricircolo di sfere

Guide units with recirculating ball bearing

Führungseinheiten mit Kugellagerführungen

Unités de guidage avec douilles à billes

Unidad de guiado con cojinetes de bolas

- Ø20 - Ø25
- Ø12 - Ø16

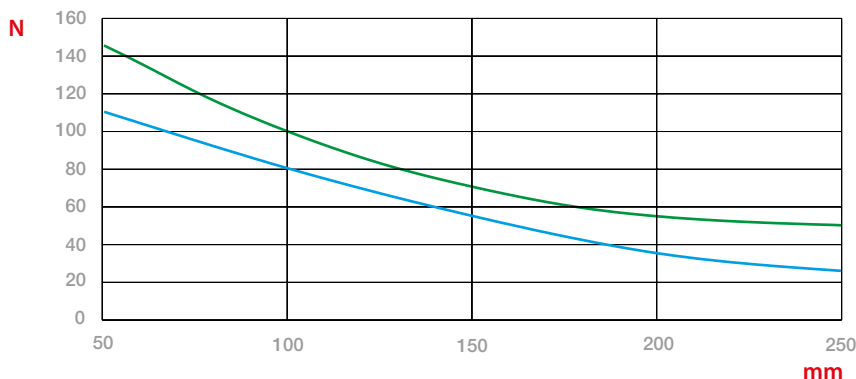

Art. VLCHC

Unità di guida con cuscinetti a ricircolo di sfere

Guide units with recirculating ball bearing

Führungseinheiten mit Kugellagerführungen

Unités de guidage avec douilles à billes

Unidad de guiado con cojinetes de bolas

Guias com rolamento de esferas recirculantes

- Ø80 - Ø100
- Ø63
- Ø50
- Ø40
- Ø32

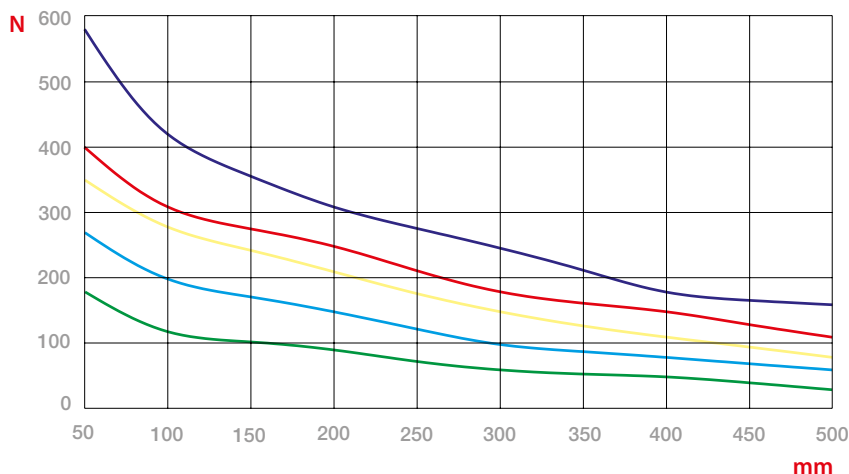

Art. VLCUB

Unità di guida con bussole in bronzo

Guide units with self lubricating sintered bush

Führungseinheiten mit Gleitlager aus Bronze

Unités de guidage avec palier en bronze

Unidad de guiado con cojinetes de bronce

Guias com bucha de bronze

- Ø100
- Ø80
- Ø63
- Ø50
- Ø40
- Ø20 - 25 - 32
- Ø16

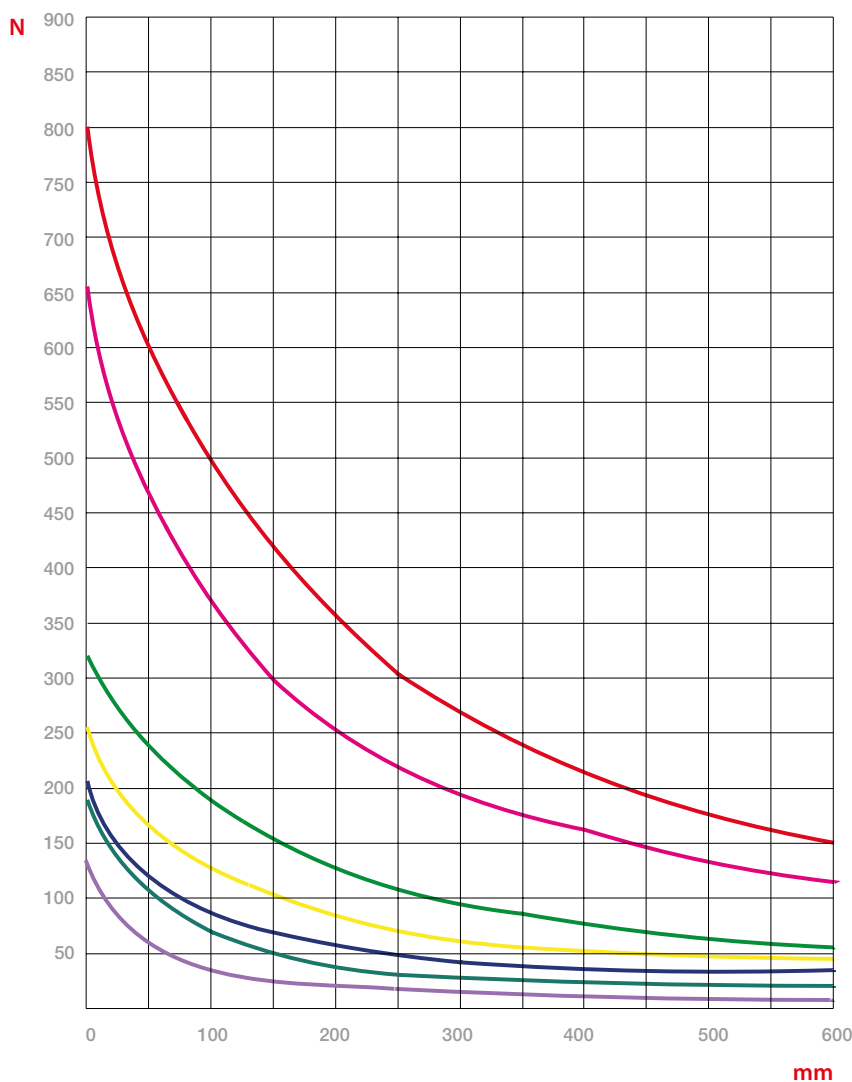

MLCUB

ISO 6432

UNITA' DI GUIDA AD "U" CON BUSSOLE IN BRONZO

GUIDE UNIT "U" WITH SELF LUBRICATING SINTERED BRONZE

FÜHRUNGSEINHEITEN "U" MIT GLEITLAGER AUS BRONZE SELBSTSCHMIEREND

UNITÉS DE GUIDAGE "U" AVEC PALIERS EN BRONZE AUTOLUBRIFIANTS

UNIDAD DE GUIADO TIPO "U" CON COJINETES DE BRONCE

GUIA EM "U" COM BUCHA DE BRONZE

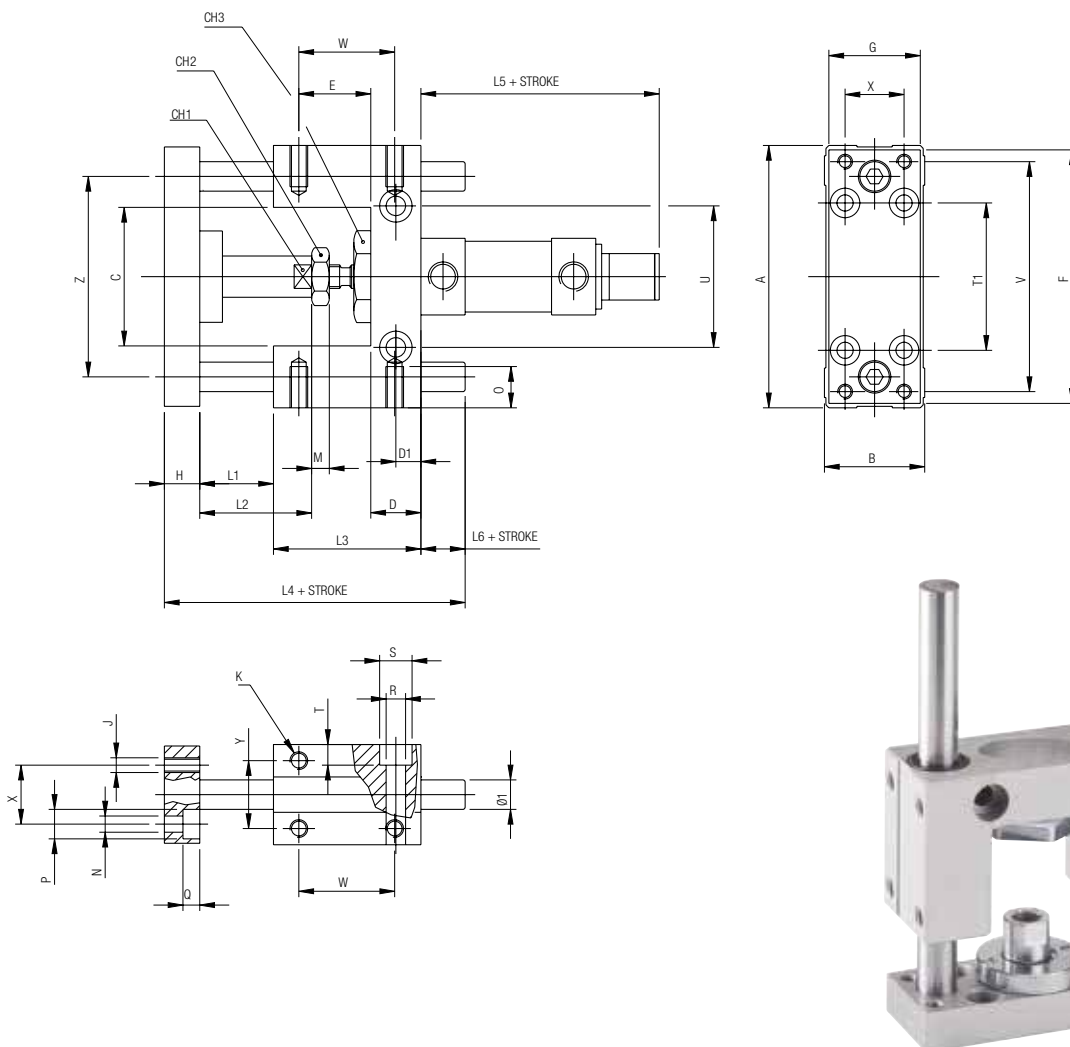

Ø	A	B	C	CH1	CH2	CH3	D	D1	E	F	G	H	Ø1	J	K	L1	L2	L3	L4	L5	L6
12 - 16	69	30	30	8	10	24	12	5.5	19.5	66	29	10	10	M4	M4	3	15	38	66.5	73	15.5
20	79	34	37	12	13	27	17	8.75	24.25	78	32	12	12	M5	M6	5	18	48	83	87	18
25	79	34	37	12	17	27	17	8.75	24.25	78	32	12	12	M5	M6	5	18	48	83	91	18

Ø	M	N	O	P	Q	R	S	T	T1	U	V	W	X	Y	Z
12 - 16	6	4.5	6	7.5	4.5	5.5	9	5.5	32	24	58	25	18	22	49.5
20	8	5.5	9	10	7.5	6.5	11	6.5	38	38	68	32.5	20	23	58
25	8	5.5	9	10	7.5	6.5	11	6.5	38	38	68	32.5	20	23	58

Ø mm	Corse - Strokes - Hub - Courses - Carreras - Cursos mm			
	50	100	160	200
12 - 16	▲	▲	▲	▲
20	▲	▲	▲	▲
25	▲	▲	▲	▲

MLCHB

ISO 6432

UNITA' DI GUIDA AD "H" CON BUSSOLE IN BRONZO

GUIDE UNIT "H" WITH SELF LUBRICATING SINTERED BRONZE

FÜHRUNGSEINHEITEN "H" MIT GLEITLAGER AUS BRONZE SELBSTSCHMIEREND

UNITÉS DE GUIDAGE "H" AVEC PALIERS EN BRONZE AUTOLUBRIFIANTS

UNIDAD DE GUIADO TIPO "H" CON COJINETES DE BRONCE

GUIA EM "H" COM BUCHA DE BRONZE

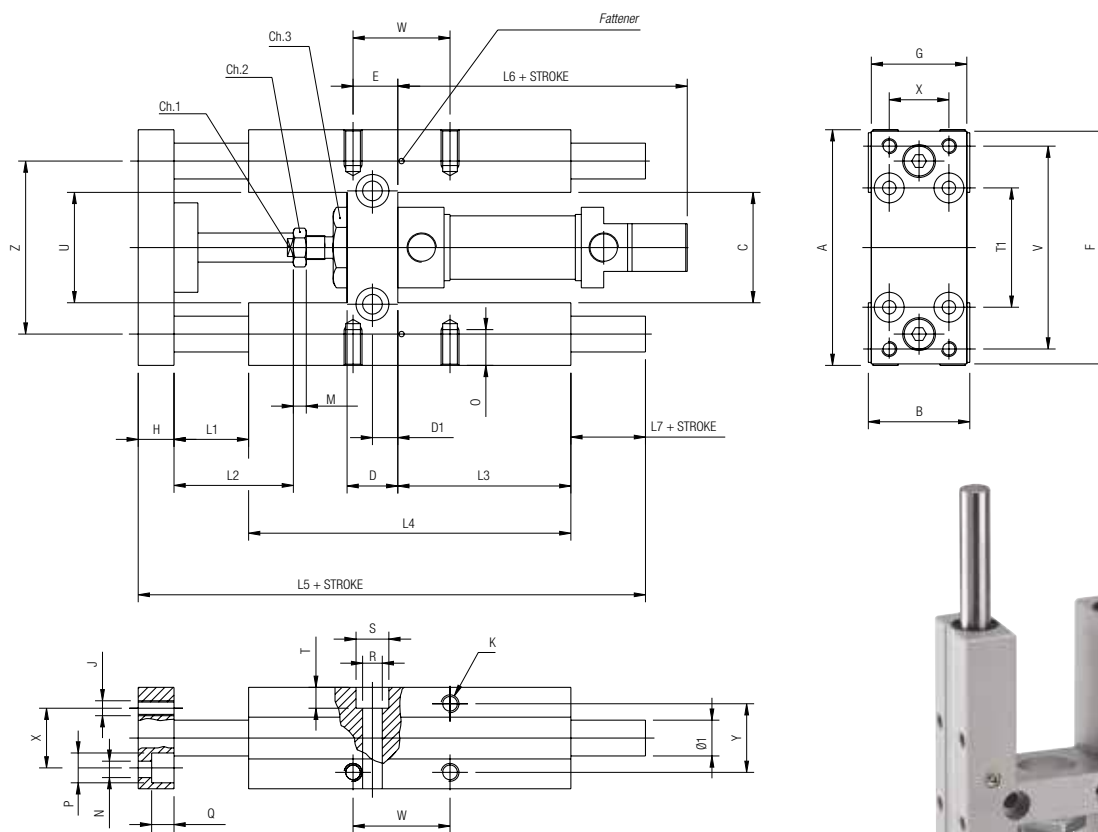

Ø	A	B	C	CH1	CH2	CH3	D	D1	E	F	G	H	Ø1	J	K	L1	L2	L3	L4	L5	L6
12 - 16	69	30	30	8	10	24	12	6	8	66	29	10	10	M4	M4	25	18	46	68	123.5	73
20	79	34	37	12	13	27	17	8.5	15	78	32	12	12	M5	M6	25	40	58	108	166	87
25	79	34	37	12	17	27	17	8.5	15	78	32	12	12	M5	M6	25	40	58	108	166	91

Ø	L7	M	N	O	P	Q	R	S	T	T1	U	V	W	X	Y	Z
12 - 16	12	6	4.5	6	8	4.5	5.5	9	5.5	32	24	58	18	18	22	49.5
20	10	8	5.5	9	10	7.5	6.5	11	6.5	38	38	68	32.5	20	23	58
25	10	8	5.5	9	10	7.5	6.5	11	6.5	38	38	68	32.5	20	23	58

Ø mm	Corse - Strokes - Hub - Courses - Carreras - Cursos mm				
	50	100	160	200	250
12 - 16	▲	▲	▲	▲	▲
20	▲	▲	▲	▲	▲
25	▲	▲	▲	▲	▲

MLCHC

ISO 6432

UNITA' DI GUIDA AD "H" CON CUSCINETTI A RICIRCOLO DI SFERE

GUIDE UNIT "H" WITH RECIRCULATING BALL SLEEVES
 FÜHRUNGSEINHEITEN "H" MIT KUGELLAGERFÜHRUNGEN
 UNITÉS DE GUIDAGE "H" AVEC DOUILLES À BILLES
 UNIDAD DE GUIADO TIPO "H" CON COJINETES DE BOLAS
 GUIA EM "H" COM ROLAMENTO DE ESFERAS RECIRCULANTE

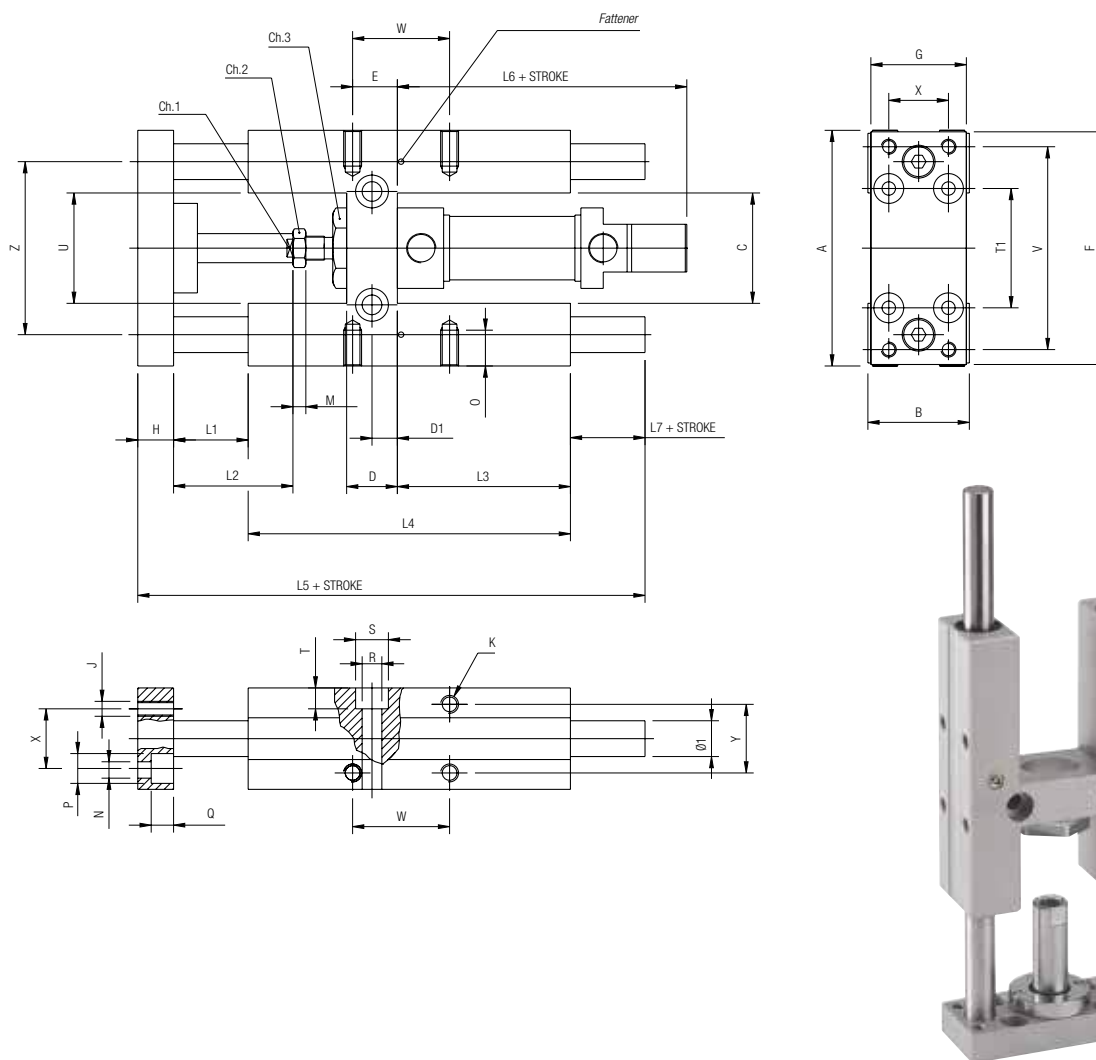

Ø	A	B	C	CH1	CH2	CH3	D	D1	E	F	G	H	Ø1	J	K	L1	L2	L3	L4	L5	L6
12 - 16	69	30	30	8	10	24	12	6	8	66	29	10	10	M4	M4	25	18	46	68	123.5	73
20	79	34	37	12	13	27	17	8.5	15	78	32	12	12	M5	M6	25	40	58	108	166	87
25	79	34	37	12	17	27	17	8.5	15	78	32	12	12	M5	M6	25	40	58	108	166	91

Ø	L7	M	N	O	P	Q	R	S	T	T1	U	V	W	X	Y	Z
12 - 16	12	6	4.5	6	8	4.5	5.5	9	5.5	32	24	58	18	18	22	49.5
20	10	8	5.5	9	10	7.5	6.5	11	6.5	38	38	68	32.5	20	23	58
25	10	8	5.5	9	10	7.5	6.5	11	6.5	38	38	68	32.5	20	23	58

Ø mm	Corse - Strokes - Hub - Courses - Carreras - Cursos mm				
	50	100	160	200	250
12 - 16	▲	▲	▲	▲	▲
20	▲	▲	▲	▲	▲
25	▲	▲	▲	▲	▲

VLCUB

ISO 15552

UNITA' DI GUIDA AD "U" CON BUSSOLE IN BRONZO

GUIDE UNIT "U" WITH SELF LUBRICATING SINTERED BRONZE

FÜHRUNGSEINHEITEN "U" MIT KUGELLAGERFÜHRUNGEN

UNITÉS DE GUIDAGE "U" AVEC PALIERS EN BRONZE AUTOLUBRIFIANTS

UNIDAD DE GUIADO TIPO "U" CON COJINETES DE BRONCE

GUIA EM "U" COM BUCHA DE BRONE

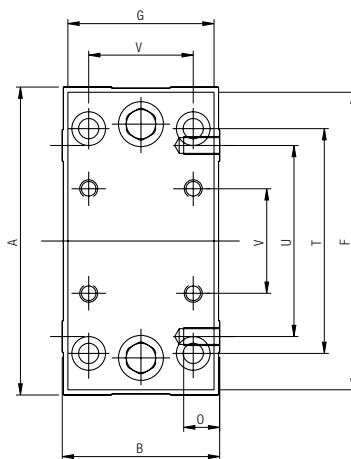
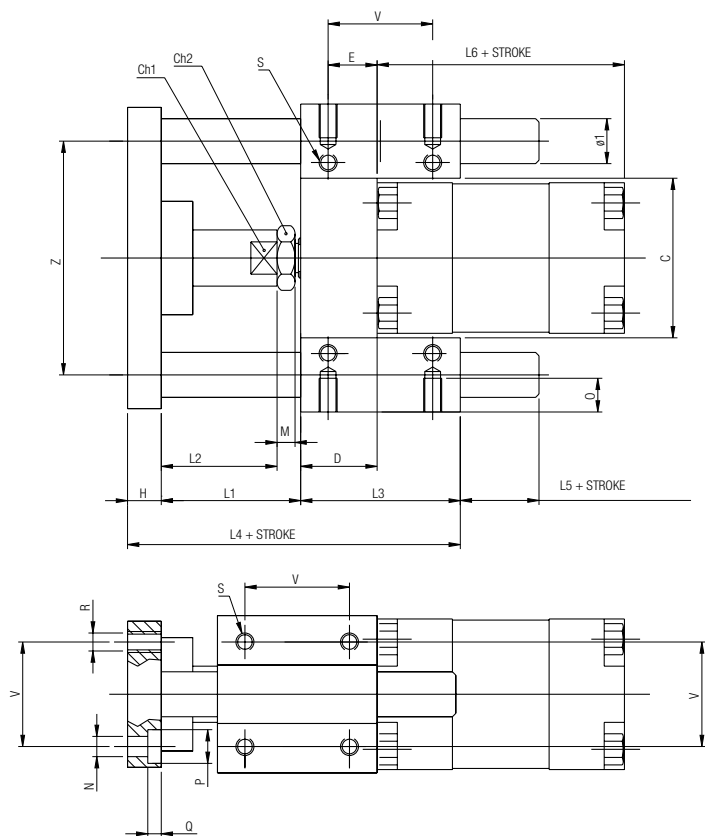

Ø	A	B	C	CH1	CH2	D	E	F	G	H	Ø1	L1	L2	L3	L4	L5	L6	M	N	O
32	97	49	51	15	17	17	9.25	93	45	12	12	42	25	48	102	18	97	8	6.6	12
40	115	58	58.5	15	19	21	11	112	55	12	16	43	24	58	113	17	109	7	6.6	12
50	137	70	70.2	20	24	25	18.8	134	65	15	20	49	30	59	123	20	110	6	9	16
63	152	85	85.2	20	24	25	15.3	147	80	15	20	49	30	76	140	21	125	6	9	16

Ø	P	Q	R	S	T	U	V	Z
32	11	6.5	M6	M6	78	61	32.5	74
40	11	6.5	M6	M6	84	69	38	87
50	15	8.5	M8	M8	100	85	46.5	104
63	15	9	M8	M8	105	100	56.5	119

Ø mm	Corse - Strokes - Hub - Courses - Carreras - Cursos mm							
	50	100	160	200	250	320	400	500
32	▲	▲	▲	▲	▲	▲	▲	▲
40	▲	▲	▲	▲	▲	▲	▲	▲
50	▲	▲	▲	▲	▲	▲	▲	▲
63	▲	▲	▲	▲	▲	▲	▲	▲

VLCHB

ISO 15552

UNITA' DI GUIDA AD "H" CON BUSSOLE IN BRONZO

GUIDE UNIT "H" WITH SELF LUBRICATING SINTERED BRONZE
 FÜHRUNGSEINHEITEN "H" MIT GLEITLAGER AUS BRONZE SELBSTSCHMIEREND
 UNITÉS DE GUIDAGE "H" AVEC PALIERS EN BRONZE AUTOLUBRIFIANTS
 UNIDAD DE GUIADO TIPO "H" CON COJINETES DE BRONCE
 GUIA EM "H" COM BUCHA DE BRONZE

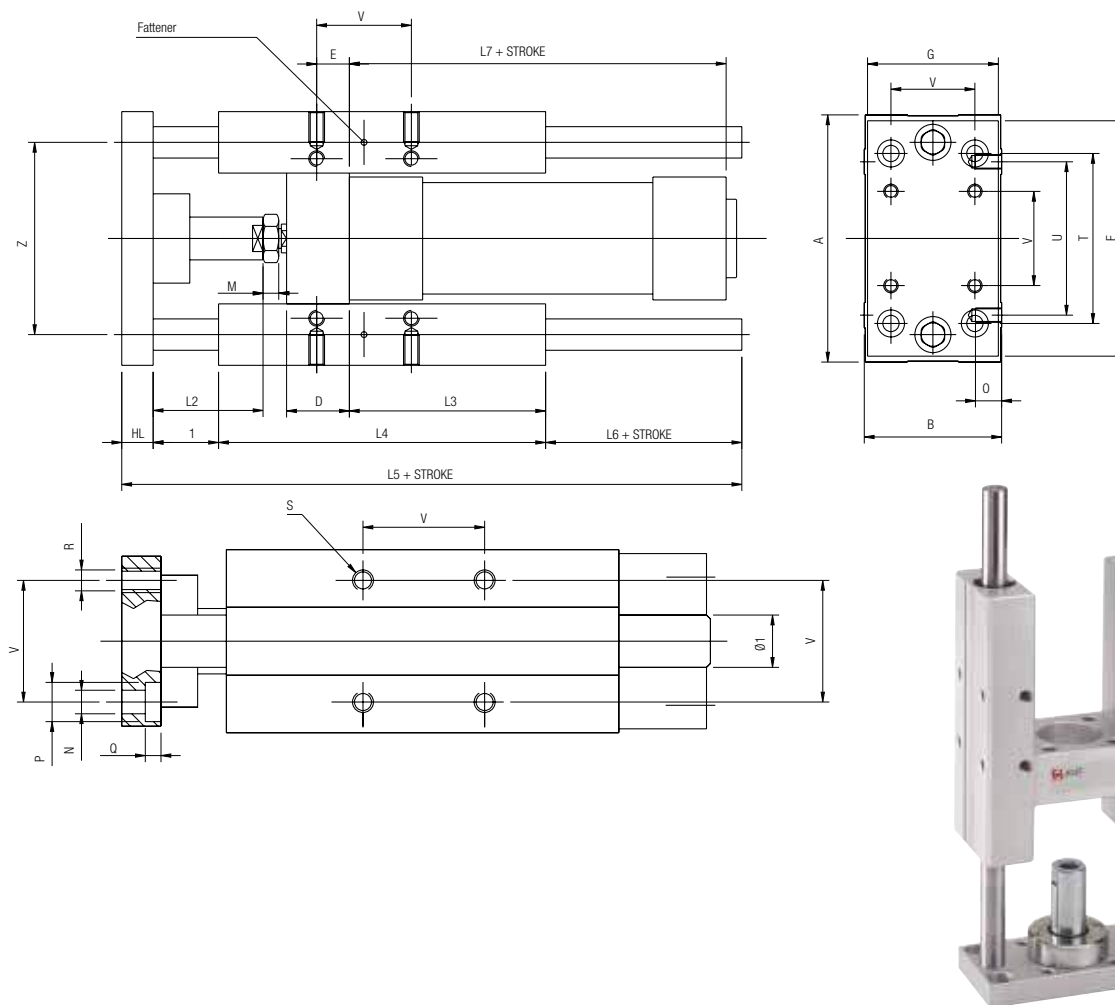

Ø	A	B	C	CH1	CH2	D	E	F	G	H	Ø1	L1	L2	L3	L4	L5	L6	L7	M	N	O
32	97	49	51	15	17	24	4.3	93	45	12	12	25	42	75	125	187	25	97	8	6.6	12
40	115	58	58.2	15	19	28	11	112	55	12	16	25	42	80	140	207	30	109	7	6.6	12
50	137	70	70.2	20	24	34	18.8	134	65	15	20	25	50	78	148	223	35	110	6	9	16
63	152	85	85.2	20	24	34	15.3	147	80	15	20	25	50	106	178	243	25	125	6	9	16
80	189	105	105.5	26	30	50	25	180	100	20	25	25	50	111	195	267	27	133	9	11	20
100	213	130	130.5	26	30	55	30	206	120	20	25	25	50	128	218	290	27	144	9	11	20

Ø	P	Q	R	S	T	U	V	Z
32	11	6.5	M6	M6	78	61	32.5	74
40	11	6.5	M6	M6	84	69	38	87
50	15	8.5	M8	M8	100	85	46.5	104
63	15	9	M8	M8	105	100	56.5	116
80	18	11	M10	M10	130	130	72	148
100	16.5	11	M10	M10	150	150	89	173

Ø mm	Corse - Strokes - Hub - Courses - Carreras - Cursos mm							
	50	100	160	200	250	320	400	500
32	▲	▲	▲	▲	▲	▲	▲	▲
40	▲	▲	▲	▲	▲	▲	▲	▲
50	▲	▲	▲	▲	▲	▲	▲	▲
63	▲	▲	▲	▲	▲	▲	▲	▲
80	▲	▲	▲	▲	▲	▲	▲	▲
100	▲	▲	▲	▲	▲	▲	▲	▲

VLCHC

ISO 15552

UNITA' DI GUIDA AD "H" CON CUSCINETTI A RICIRCOLO DI SFERE

GUIDE UNIT "H" WITH RECIRCULATING BALL SLEEVES

FÜHRUNGSEINHEITEN "H" MIT KUGELLAGERFÜHRUNGEN

UNITÉS DE GUIDAGE "H" AVEC DOUILLES À BILLES

UNIDAD DE GUIADO TIPO "H" CON COJINETES DE BOLAS

GUIA EM "H" COM ROLAMENT DE ESFERAS RECIRCULANTES

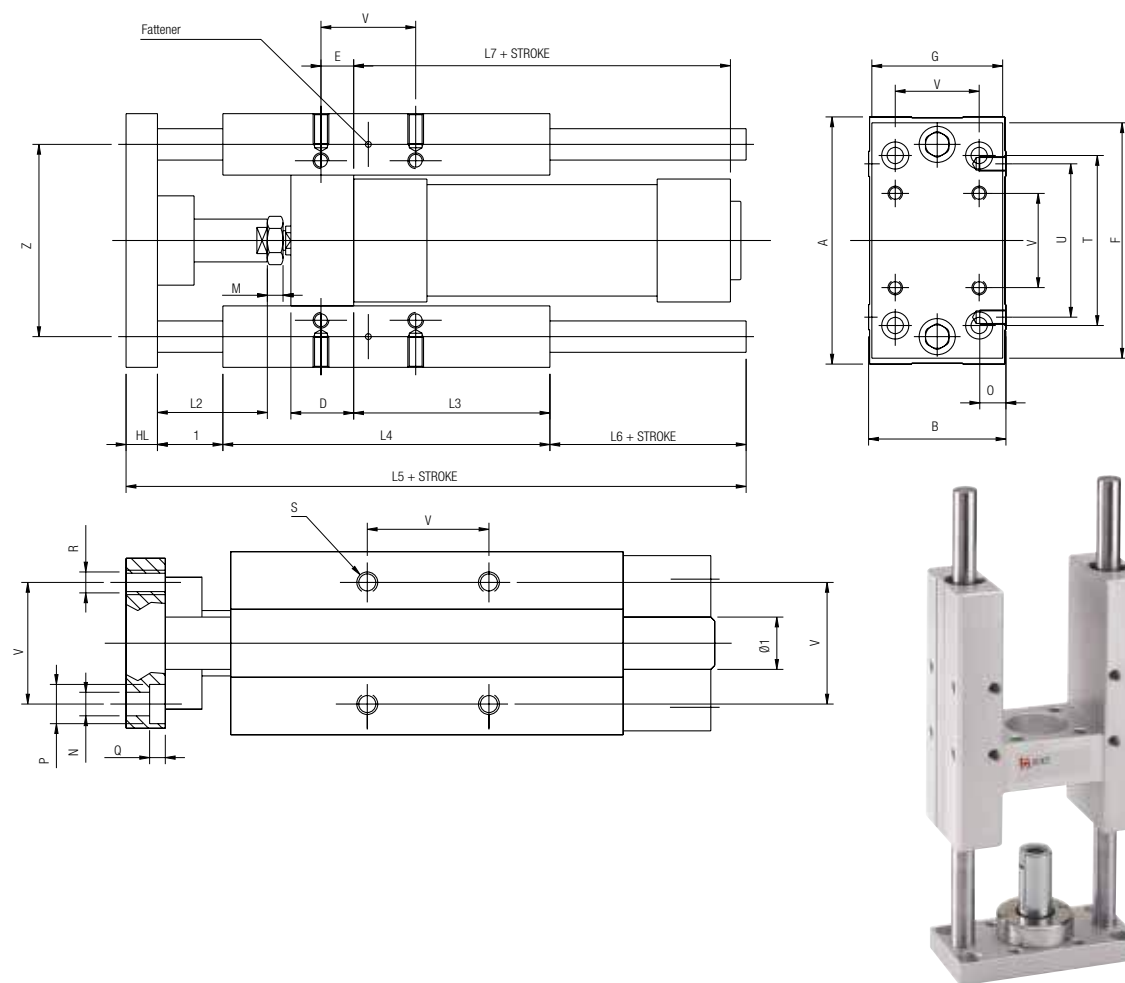

Ø	A	B	C	CH1	CH2	D	E	F	G	H	Ø1	L1	L2	L3	L4	L5	L6	L7	M	N	O
32	97	49	51	15	17	24	4.3	93	45	12	12	25	42	75	125	187	25	97	8	6.6	12
40	115	58	58.2	15	19	28	11	112	55	12	16	25	42	80	140	207	30	109	7	6.6	12
50	137	70	70.2	20	24	34	18.8	134	65	15	20	25	50	78	148	223	35	110	6	9	16
63	152	85	85.2	20	24	34	15.3	147	80	15	20	25	50	106	178	243	25	125	6	9	16
80	189	105	105.5	26	30	50	25	180	100	20	25	25	50	111	195	267	27	133	9	11	20
100	213	130	130.5	26	30	55	30	206	120	20	25	25	50	128	218	290	27	144	9	11	20

Ø	P	Q	R	S	T	U	V	Z
32	11	6.5	M6	M6	78	61	32.5	74
40	11	6.5	M6	M6	84	69	38	87
50	15	8.5	M8	M8	100	85	46.5	104
63	15	9	M8	M8	105	100	56.5	116
80	18	11	M10	M10	130	130	72	148
100	16.5	11	M10	M10	150	150	89	173

Ø mm	Corse - Strokes - Hub - Courses - Carreras - Cursos mm							
	50	100	160	200	250	320	400	500
32	▲	▲	▲	▲	▲	▲	▲	▲
40	▲	▲	▲	▲	▲	▲	▲	▲
50	▲	▲	▲	▲	▲	▲	▲	▲
63	▲	▲	▲	▲	▲	▲	▲	▲
80	▲	▲	▲	▲	▲	▲	▲	▲
100	▲	▲	▲	▲	▲	▲	▲	▲