

SERIE 190 MULTISOCKET



Un'unica presa per 4 tipi di innesti

IT

E' un dato di fatto che sul mercato esistono vari profili di innesti ben distinti sia nella forma che nelle dimensioni e generalmente necessitano di essere assemblati con specifiche prese che di norma non sono intercambiabili fra di loro.

Per poter ovviare a questa incompatibilità AIGNEP propone alla sua clientela una soluzione pratica ed economica, un'unica presa da utilizzare con 4 differenti tipi di profili garantendo per tutti una perfetta tenuta.

One socket for 4 different plugs

GB

It is a matter of fact that on the market are available various types of plugs well distinguished whether on the shape or on the dimensions, usually they need to be assembled with specific sockets which normally are not interchangeable.

To get round to this incompatibility AIGNEP is proud to offer to its customers a practical and cost-effective solution, a unique socket to be used with 4 different types of plugs, ensuring a perfect tightening.

1 Kupplung Für 4 Typen Von Steckern

DE

Es ist eine Tatsache, dass die auf dem Markt verfügbaren Kupplungen und Stecker mit verschiedenen, nicht kompatiblen Profilen in Form und Größe geliefert werden, d.h. sie können nicht untereinander ausgetauscht montiert werden.

Um diese Austauschbarkeit zu ermöglichen, bietet AIGNEP seinen Kunden eine praktische und kostengünstige Lösung an, wo mit einer Kupplung 4 verschiedene Profile (Stecker) verwendet werden können und dennoch eine perfekte Abdichtung gewährleistet ist.

1 Corps pour 4 Embouts

FR

Le marché met à disposition des utilisateurs des différents types de coupleurs qui varient selon les normes, la forme et les dimensions. Souvent il est nécessaire d'assembler plusieurs types de coupleurs qui ne sont pas interchangeables.

Pour contourner cette incompatibilité AIGNEP est fière d'offrir à ses clients une solution pratique, fiable et rentable où un corps unique pour être utilisé avec 4 embouts différents.

Un único enchufe para 4 tipos de adaptador

ES

Es un dato a remarcar que en el mercado existen varios tipos de adaptadores distintos, ya sea en la forma como en las dimensiones, que generalmente necesitan de enchufes específicos no intercambiables entre ellos.

Para solucionar este problema AIGNEP, propone una solución práctica y económica de intercambiabilidad con todos los adaptadores homologados en el mercado europeo, garantizando para todos una perfecta estanqueidad.

Um único soquete p/ 4 tipos de plugs

PT

É um fato que no mercado existem vários perfis de plug bem diferentes entre si, seja no seu formato ou com relação às suas medidas e que, por isto normalmente não são intercambiáveis, necessitando de um soquete específico para cada diferente tipo de plug.

Para fugir desta incompatibilidade de tipos de modelos a AIGNEP propõe a seus clientes uma solução prática e econômica: um único soquete para ser utilizado com 4 diferentes tipos de perfis, garantindo para todos uma vedação perfeita.

PROFIL SWISS
SERIE 270

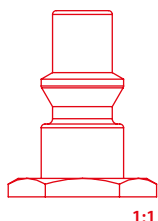

1:1

DN
5.5 mm

Pag. 15.45

PROFIL EUROPEAN
SERIE 260

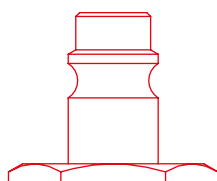

1:1

DN
7.5 - 7.8 mm

Pag. 15.39

PROFIL ITALIAN
SERIE 250

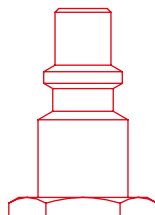

1:1

DN
5 mm

Pag. 15.23

PROFIL UNI ISO 6150 B-12
SERIE 220

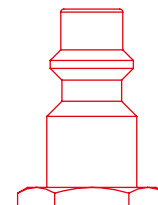

1:1

DN
5.5 mm

Pag. 15.17



CARATTERISTICHE TECNICHE

TECHNICAL CHARACTERISTICS
TECHNISCHE ANGABEN
CARACTÉRISTIQUES TECHNIQUES
CARACTERÍSTICAS TÉCNICAS
CARACTERÍSTICAS TÉCNICAS



Norma di Riferimento

Reference standard

Entspricht der Norm

Norme de référence

Normativa de referencia

Norma de referència

1907/2006

REACH ✓

2011/65/CE

RoHS ✓

PED
2014/68/UE

SILICON
FREE

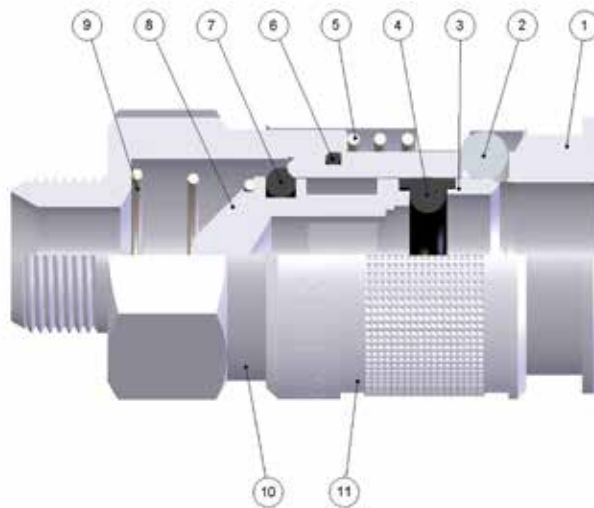

FKM A RICHIESTA
IF REQUESTED FKM
FKM AUF ANFRAGE
FKM SUR DEMANDE
FKM BAJO DEMANDA
FKM SOB ENCOMENDA

Materiali e Componenti

IT

- 1 Corpo in Ottone Nichelato
- 2 Sfera in Acciaio AISI 420
- 3 Anello Guida Innesto in Ottone Nichelato
- 4 Guarnizione O-Ring in NBR
- 5 Molla Ghiera in Acciaio AISI 302
- 6 Guarnizione O-Ring in NBR
- 7 Guarnizione O-Ring in NBR
- 8 Otturatore in Ottone Nichelato
- 9 Molla Otturatore in Acciaio AISI 302
- 10 Attacco Terminale in Ottone Nichelato
- 11 Ghiera in Ottone Nichelato

Component Parts and Materials

GB

- 1 Nickel-Plated Brass Body
- 2 Stainless Steel AISI 420 Balls
- 3 Nickel-Plated Brass Guide Ring Coupling
- 4 NBR O-Ring Seals
- 5 Stainless Steel AISI 302 Ring Nut Spring
- 6 NBR O-Ring Seals
- 7 NBR O-Ring Seals
- 8 Nickel-Plated Brass Shutter
- 9 Stainless Steel AISI 302 Shutter Spring
- 10 Nickel-Plated Brass Coupling Back Part
- 11 Nickel-Plated Brass Sleeve

Komponenten und Materialien

DE

- 1 Körper Messing Vernickelt
- 2 Kugel Edelstahl AISI 420
- 3 Ring Aus Messing
- 4 O-Ring NBR
- 5 Entriegelungsfeder Edelstahl AISI 302
- 6 O-Ring NBR
- 7 O-Ring NBR
- 8 Verschluss Messing Vernickelt
- 9 Verschlussfeder Edelstahl AISI 302
- 10 Einschraubkörper Messing Vernickelt
- 11 Entriegelungshülse Messing Vernickelt

Matériaux et Composants

FR

- 1 Corps: Laiton Nickelé
- 2 Bille: Acier Inoxydable AISI 420
- 3 Bague en Laiton
- 4 Joint Torique en NBR
- 5 Ressort de Bague: Acier Inoxydable AISI 302
- 6 Joint Torique en NBR
- 7 Joint Torique en NBR
- 8 Clapet en Laiton Nickelé
- 9 Ressort de Clapet: Acier Inoxydable AISI 302
- 10 Corps: Laiton Nickelé
- 11 Bague: Laiton Nickelé

Materiales y Componentes

ES

- 1 Cuerpo en latón niquelado
- 2 Esfera en acero AISI 420
- 3 Anillo guía enchufe en latón niquelado
- 4 Junta tórica en NBR
- 5 Muelle tuerca en acero AISI 302
- 6 Junta tórica en NBR
- 7 Junta tórica en NBR
- 8 Obturador en latón niquelado
- 9 Muelle obturador en acero AISI 302
- 10 Conexión terminal en latón niquelado
- 11 Tuerca en latón niquelado

Materiais e Componentes

PT

- 1 Corpo em latão niquelado
- 2 Esfera em aço AISI 420
- 3 Anel guia do plug em latão niquelado
- 4 Vedação O-Ring em NBR
- 5 Mola de porca em aço AISI 302
- 6 Vedação O-Ring em NBR
- 7 Vedação O-Ring em NBR
- 8 Obturador em latão niquelado
- 9 Mola do obturador em aço AISI 302
- 10 Conexão terminal em latão niquelado
- 11 Porca em latão niquelado



Temperature

Temperatures

Temperatur

Températures

Temperaturas

Temperaturas

- 20 °C

+ 80 °C

Con O-ring in FKM
With FKM O-ring
Mit O-ring in FKM
Avec Joints en FKM
Con Junta tórica en FKM
Com O-ring em FKM

- 10 °C
+ 200 °C



Fluidi compatibili

Aria compressa

Fluids

Compressed air

Geeignete Medien

Druckluft

Fluides compatibles

Air comprimé

Fluidos compatibles

Aire comprimido

Fluidos compatíveis

Ar comprimido

Per altri fluidi, consultare l'ufficio tecnico Aignep.

For other fluids, consult the technical department Aignep.

Für andere Flüssigkeiten, kontaktieren Sie uns.

Pour d'autres fluides, veuillez nous consulter.

Para otros fluidos póngase en contacto con el departamento técnico Aignep.

Para outros fluidos consulte o departamento técnico da Aignep.



Pressione d'esercizio

Working Pressures

Betriebsdruck

Pression de service

Presión de Ejercicio

Pressão de Trabalho

0 bar

16 bar



Max pressione statica (no pulsazioni)

Maximum static pressure (no pulsations)

Maximaler statischer Betriebsdruck (ohne pulsations)

Pression statique maximale (sans pulsation)

Presión estática máxima (sin pulsaciones)

Pressão estática máxima (sem pulsações)

35 bar



Portata

NI/min

Flow Rate

Durchflusswerte

Débit

Caudal de Flujo

Vazão

Innesto Plug Stecker Embout Adaptador Plug	6 bar Δ 1	6 bar Δ 0.5	6 bar Δ 0*
220	900	700	1450
250	800	700	1300
260	1350	1000	2150
260	1510	1200	2250
270	1100	750	1600

* Scarico libero - Exhaust Free - Kostenlose Auspuff - Échappement libre - Escape Libre - Descarga libre.



Filettatura

IT

Threads

GB

Gewindearten

DE

Gas cilindrica conforme ISO 228 Classe A.

Parallel gas in conformity with ISO 228 Class A.

Zylindrisches Gewinde nach Norm ISO 228 Classe A.

Filetages

FR

Roscas

ES

Roscas

PT

Filetage cylindrique conforme: ISO 228 Class A.

Gas cilíndrica conforme ISO 228 Clase A.

Gas paralela conforme ISO 228 Classe A.

191

PRESA CON ATTACCO MASCHIO

MALE SOCKET

VERSCHLUSS-KUPPLUNG MIT AUSSENGEWINDE

COUPLEUR MÂLE

ENCHUFE MACHO

SOQUETE COM ROSCA MACHO

Code	A	B	C	D	CH	Pack.
00191 00 001	1/4	8	49	24	21	10
00191 00 002	3/8	9	50	24	21	10
00191 00 003	1/2	10	51	24	24	10

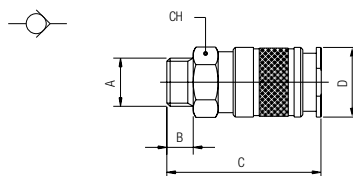

192

PRESA CON ATTACCO FEMMINA

FEMALE SOCKET

VERSCHLUSS-KUPPLUNG MIT INNENGEWINDE

COUPLEUR FEMELLE

ENCHUFE HEMBRA

SOQUETE COM ROSCA FÊMEA

Code	A	B	C	D	CH	Pack.
00192 00 001	1/4	11	51	24	21	10
00192 00 002	3/8	11.5	51	24	21	10
00192 00 003	1/2	14	55	24	24	10

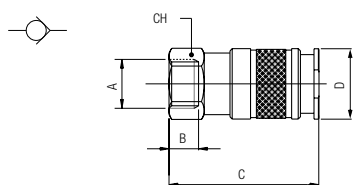

193**PRESA CON ATTACCO A CALZAMENTO CON MOLLA**

COMPRESSION SOCKET WITH SPRING

VERSCHLUSS-KUPPLUNG MIT KNICKSCHUTZFEDER

COUPLEUR AVEC RESSORT DE PROTECTION

ENCHUFE TUBO CON MUELLE

SOQUETE COM CONEXÃO PUSH-ON COM MOLLA

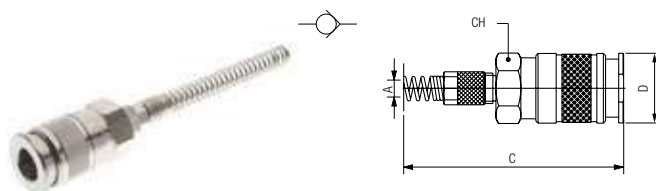

Code	A	B	C	D	CH	Pack.
00193 00 001	6/4	-	138	24	21	10
00193 00 002	8/6	-	144.5	24	21	10
00193 00 004	10/6.5	-	153.5	24	21	10
00193 00 003	10/8	-	153.5	24	21	10
00193 00 005	12/10	-	159	24	21	10

194**PRESA CON ATTACCO A CALZAMENTO**

COMPRESSION SOCKET

VERSCHLUSS-KUPPLUNG MIT ÜBERWURFVERSCHRAUBUNG

COUPLEUR RACCORD À COIFFE

ENCHUFE TUBO

SOQUETE COM CONEXÃO PUSH-ON

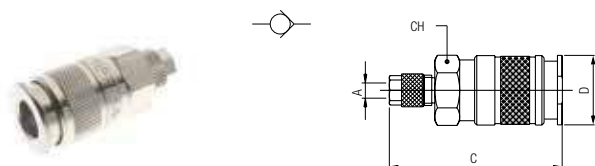

Code	A	B	C	D	CH	Pack.
00194 00 001	6/4	-	55	24	21	10
00194 00 002	8/6	-	55	24	21	10
00194 00 003	10/8	-	55	24	21	10
00194 00 007	12/10	-	57.5	24	21	10

195**PRESA CON PORTAGOMMA A RESCA**

SOCKET WITH REST FOR RUBBER HOSE

VERSCHLUSS-KUPPLUNG MIT SCHLAUCHTÜLLE

COUPLEUR À DOUILLE ANNELÉE POUR TUBE

ENCHUFE EPIGA

SOQUETE COM EPIGÃO PARA MANGUEIRA DE BORRACHA

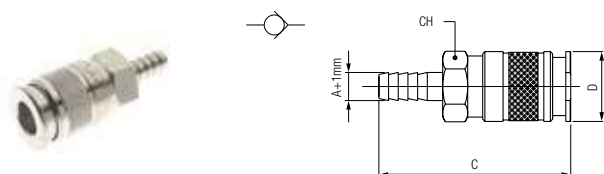

Code	A	B	C	D	CH	Pack.
00195 00 001	6	-	61	24	21	10
00195 00 002	8	-	61	24	21	10
00195 00 003	10	-	61	24	21	10
00195 00 004	12	-	61	24	21	10

196**PRESA CON PORTAGOMMA**

SOCKET FOR RUBBER HOSE

VERSCHLUSS-KUPPLUNG FÜR GUMMISCHLAUCH

COUPLEUR À DOUILLE ANNELÉE POUR TUBE

ENCHUFE CON PORTAGOMA

SOQUETE COM EPIGÃO PARA TUBO DE BORRACHA

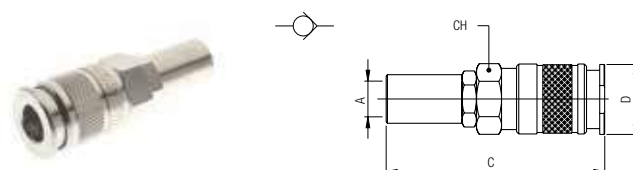

Code	A	B	C	D	CH	Pack.
00196 00 001	14/6	-	71	24	21	10
00196 00 002	17/8	-	71	24	21	10
00196 00 003	19/10	-	71	24	21	10