

GIUNTI AD INNESTO RAPIDO PER RAFFREDDAMENTO STAMPI

QUICK COUPLINGS FOR MOLDING COOLING

SCHNELLKUPPLUNGEN FÜR SPRITZGUSSANWENDUNGEN

COUPLEURS POUR REFROIDISSEMENT EAU DES MOULES D'INJECTION

ENCHUFES RÁPIDOS PARA REFRIGERACIÓN DE MOLDES

CONEXÕES DE ENGATE RÁPIDO PARA RESFRIAMENTO DE MOLDES

Serie French



SERIE 410 - 420 FRENCH PROFILE



CARATTERISTICHE TECNICHE

TECHNICAL CHARACTERISTICS
TECHNISCHE ANGABEN
CARACTÉRISTIQUES TECHNIQUES
CARACTERÍSTICAS TÉCNICAS
CARACTERÍSTICAS TÉCNICAS



Norma di Riferimento

Reference standard
Entspricht der Norm
Norme de référence
Normativa de referencia
Norma de referència

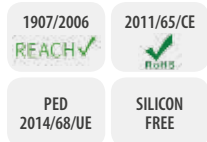

DN 8 - DN12

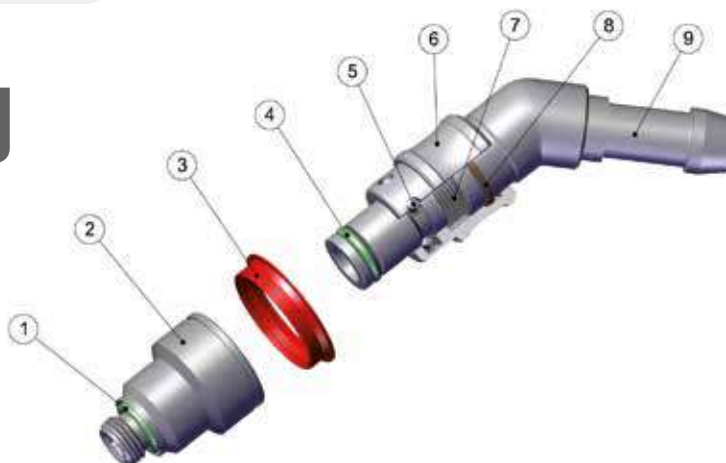

Materiali e Componenti	IT	Component Parts and Materials	GB	Komponenten und Materialien	DE
1 Guarnizione O-Ring in FKM		1 FKM O-Ring seal		1 O-Ring FKM	
2 Presa in ottone nichelato		2 Nickel-plated brass socket		2 Kupplung Messing vernickelt	
3 Anello in PA66		3 PA66 ring		3 Ring PA66	
4 Guarnizione O-Ring in FKM		4 FKM O-Ring seal		4 O-Ring FKM	
5 Sfera in acciaio AISI 420		5 Steel AISI 420 ball		5 Kugel Edelstahl AISI 420	
6 Ghiera in ottone nichelato		6 Nickel-plated brass sleeve		6 Entriegelungshülse Messing vernickelt	
7 Molla in acciaio AISI 302		7 Steel AISI 302 spring		7 Feder Edelstahl AISI 302	
8 Seeger in bronzo		8 Bronze seeger		8 Seegerring Bronze	
9 Corpo in ottone nichelato		9 Nickel-plated brass body		9 Körper Messing vernickelt	

Matériaux et Composants	FR	Materiales y Componentes	ES	Materiais e Componentes	PT
1 Joint torrique: FKM		1 Junta tórica en FKM		1 Vedação O-Ring em FKM	
2 Coupleur: laiton nickelé		2 Enchufe en latón niquelado		2 Soquete em Latão Niquelado	
3 Bague: PA66		3 Anillo en PA66		3 Anel em PA66	
4 Joint torrique: FKM		4 Junta tórica en FKM		4 Vedação O-Ring em FKM	
5 Bille: acier inoxydable AISI 420		5 Esfera en acero AISI 420		5 Esfera em aço AISI 420	
6 Douille: laiton nickelé		6 Tuerca en latón niquelado		6 Porca em Latão Niquelado	
7 Ressort: acier inoxydable AISI 302		7 Muelle en acero AISI 302		7 Mola em aço AISI 302	
8 Circlips : bronze		8 Seeger en bronze		8 Anel de retenção tipo Seeger em bronze	
9 Corps: laiton nickelé		9 Cuerpo en latón niquelado		9 Corpo em Latão Niquelado	



La particolare struttura comporta ingombri ridotti e consente l'innestaggio con una sola mano.

The particular structure that assures reduced size and allows coupling using a single hand.

Die besondere struktur umfasst reduzierte abmessungen und erlaubt ein einkoppeln mit einer hand.

La structure comprenant des dimensions réduites permet un couplage avec une main.

La estructura particular de la línea ofrece dimensiones reducidas y consiente la conexión con una sola mano.

Possui um estrutura particular que garante tamanho reduzido e permite o acoplamento usando apenas uma mão.

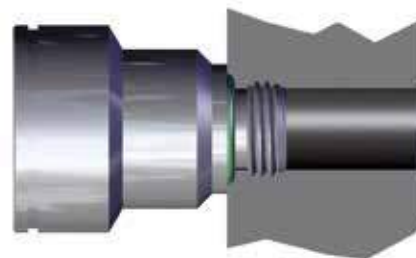

Pressioni e Temperature

IT

Pressioni e temperature sono determinate dal tipo di tubo impiegato, pertanto tali valori sono da definirsi in base alle caratteristiche del tubo stesso.

I valori riguardano quindi esclusivamente i componenti da noi prodotti.

Pressures and Temperatures

GB

The working pressures and working temperatures depend on which type of tube is used, for this reason, the values must be determined in accordance with the tube's features.

The following values apply only to our products.

Druckbereich und Temperatur

DE

Drücke und Temperaturen sind definiert durch die verwendete Ausführung der Leitung, d.h. die Werte der eingesetzten Rohre sind zu beachten.

Die angegebenen Werte beziehen sich nur auf die Teile, die von uns produziert sind.

Pressions et Températures

FR

Les pressions et les températures sont à définir en accord avec les caractéristiques techniques des tubes utilisés.

Les valeurs mentionnées ne concernent que nos produits.

Presiones y Temperaturas

ES

Presión y temperaturas vienen determinadas según el tipo de tubo empleado, por lo tanto estos valores se definen en base a las características del tubo mismo.

Los valores se refieren exclusivamente a los componentes de nuestra producción.

Pressões e Temperaturas

PT

Pressões e temperaturas são determinadas de acordo com o tipo de tubo empregado, portanto tais valores devem ser definidos com base nas características do tubo em questão.

Os valores mostrados a seguir se referem apenas aos componentes de nossos produtos.

**Pressione d'esercizio**

Working Pressures

Betriebsdruck

Pression de service

Presión de Ejercicio

Pressão de Trabalho

15 bar (1.5 MPa)**Temperature**

Temperatures

Temperatur

Températures

Temperaturas

Temperaturas

- 15 °C**+ 200 °C**

con anello di riconoscimento art. 513 - 523

with identification ring art. 513 - 523

Mit Kennzeichnungsring art. 513 - 523

Avec bague d'identification art. 513 - 523

Con anillo de identificación art. 513 - 523

Com anel de identificação cód. 513 - 523

+ 110 °C**Fluidi compatibili**

Acqua / Acqua refrigerata / Olio

Fluids

Water / Cooling water / Oil

Geeignete Medien

Wasser / Kühlwasser / Öl

Fluides compatibles

Eau / Eau de refroidissement / Huile

Fluidos compatibles

Agua / Agua refrigerada / Aceite

Fluidos compatíveis

Água / Água refrigerada / Óleo

**Filettatura**

IT

Gas cilindrica conforme ISO 228 Classe A.

Gas conica conforme ISO 7.1, BS 21, DIN 2999.

Threads

GB

Parallel gas in conformity with ISO 228 Class A.

Tapered gas in conformity with ISO 7.1, BS 21, DIN 2999.

Gewindearten

DE

Zylindrisches Gewinde nach Norm ISO 228 Klasse A.

Konisches Gewinde nach Norm ISO 7.1, BS 21, DIN 2999.

Filetages

FR

Filetage cylindrique conforme: ISO 228 Classe A.

Filetage conique conforme: ISO 7.1, BS 21, DIN 2999.

Roscas

ES

Gas cilíndrica conforme ISO 228 Clase A.

Gas cónica conforme ISO 7.1, BS 21, DIN 2999.

Roscas

PT

Gas paralela conforme ISO 228 Classe A.

Gas cónica conforme ISO 7.1, BS 21, DIN 2999.

SERIE 410 - 510 FRENCH PROFILE DN8

412

INNESTO CON ATTACCO FEMMINA

FEMALE PLUG
STECKER MIT INNENGEWINDE
EMBOUT FEMELLE
ADAPTADOR HEMBRA
PLUG COM ROSCA FÊMEA

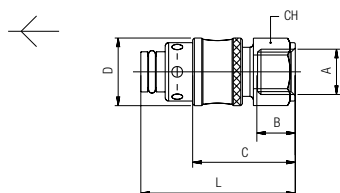

Code	A	B	C	D	L	CH	Pack.
00412 00 001	1/4	11	30	20	47	17	10

415

INNESTO CON PORTAGOMMA DIRITTO

STRAIGHT PLUG WITH REST FOR RUBBER HOSE
STECKER MIT SCHLAUCHTÜLLE
EMBOUT À DOUILLE ANNELÉE
ADAPTADOR CON PORTAGOMA RECTO
PLUG COM ESPIGÃO PARA TUBO DE BORRACHA RETO

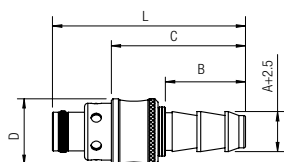
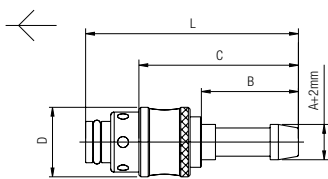

Code	A	B	C	D	L	Pack.
00415 00 001	8	27.5	45	20	62.5	10
00415 00 002	10	27.5	45	20	62.5	10
00415 00 003	12	33	50.5	20	68	10

Code	A	B	C	D	L	Pack.
00415 00 004	3/8	24	48	20	60	10
00415 00 005	1/2	28	54.5	20	66	10

416

INNESTO CON PORTAGOMMA A 135°

PLUG WITH REST FOR RUBBER HOSE TO 135°
STECKER MIT SCHLAUCHTÜLLE VON 135°
EMBOUT À 135°, À DOUILLE ANNELÉE
ADAPTADOR CON PORTAGOMA A 135°
PLUG COM ESPIGÃO PARA TUBO DE BORRACHA A 135°

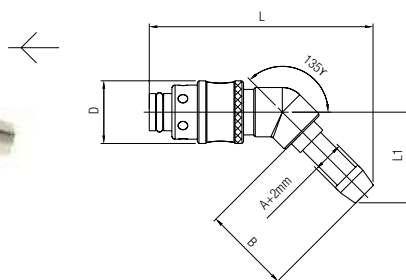

Code	A	B	C	L	L1	Pack.
00416 00 001	8	27.5	20	72.5	28.5	10
00416 00 002	10	27.5	20	73	29	10
00416 00 003	12	33	20	77.5	33.5	10

418

INNESTO CON PORTAGOMMA A 90°

PLUG WITH REST FOR RUBBER HOSE TO 90°

STECKER MIT SCHLAUCHTÜLLE VON 90°

EMBOUT À 90°, À DOUILLE ANNELÉE

ADAPTADOR CON PORTAGOMA A 90°

PLUG COM ESPIGÃO PARA TUBO DE BORRACHA A 90°

Code	A	B	C	D	L	L1	Pack.
00418 00 001	8	27.5	39.5	20	57	49	10
00418 00 002	10	27.5	39.5	20	57	49	10
00418 00 003	12	33	39.5	20	57	55	10

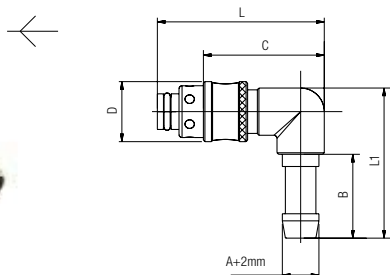

511

PRESA CON ATTACCO MASCHIO

MALE SOCKET

VERSCHLUSS-KUPPLUNG MIT AUSSENGEWINDE

COUPLEUR MÂLE

ENCHUFE MACHO

SOQUETE COM ROSCA MACHO

Code	A	B	C	L	CH	Pack.
00511 00 001	1/8	6	21	27.5	5	10
00511 00 002	1/4	8	21	29	8	10
00511 00 003	3/8	9	21	30	10	10

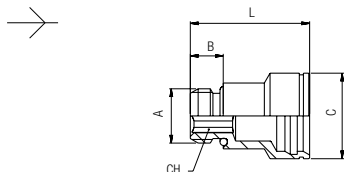

512

PRESA PROLUNGATA CON ATTACCO MASCHIO

EXTENDED MALE SOCKET

SCHNELLKUPPLUNG MIT VERLÄNGERTEM AUSSENGEWINDE

COUPLEUR MÂLE RALLONGÉ

ENCHUFE PROLONGADO MACHO

SOQUETE COM ROSCA MACHO PROLONGADA

Code	A	B	C	D	L	CH	Pack.
00512 00 01 NU NT	1/8	27	21	21	50	5	10
00512 00 01 NV NT	1/8	60	21	21	100	5	10
00512 00 01 NW NT	1/8	60	21	21	150	5	10
00512 00 01 NX NT	1/8	60	21	21	200	5	10
00512 00 01 NY NT	1/4	27	21	20	50	8	10
00512 00 01 NZ NT	1/4	60	21	20	100	8	10
00512 00 01 PA NT	1/4	60	21	20	150	8	10
00512 00 01 PB NT	1/4	60	21	20	200	8	10
00512 00 01 PC NT	3/8	35	21	11	50	10	10
00512 00 01 PD NT	3/8	60	21	11	100	10	10
00512 00 01 PE NT	3/8	60	21	11	150	10	10
00512 00 01 PF NT	3/8	60	21	11	200	10	10

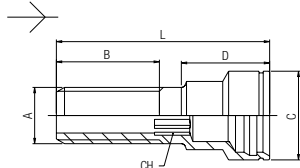

514

PRESA CON ATTACCO MASCHIO CONICO

MALE SOCKET TAPER

VERSCHLUSS-KUPPLUNG MIT AUSSENGEWINDE KONISCH

COUPLEUR MÂLE CONIQUE

ENCHUFE MACHO CÓNICO

SOQUETE COM ROSCA MACHO

Code	A	B	C	L	CH	Pack.
00514 00 01 02 TF	1/8	7.5	21	28	5	10
00514 00 01 03 TF	1/4	11	21	31	8	10
00514 00 01 04 TF	3/8	11.5	21	31	10	10

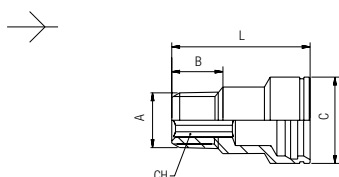



FILETTO PRE SIGILLATO
 PRE-COATING THREAD
 GEWINDE BESCHICHTET
 PRÉ-COATING
 ROSCA PRESELLADA
 ROSCA TEFLONADA

513

ANELLO DI RICONOSCIMENTO

IDENTIFICATION RING
KENNZEICHNUNGSRING
ANNEAU D'IDENTIFICATION
ANILLO DE IDENTIFICACIÓN
ANEL DE IDENTIFICAÇÃO

Code	Color	A	B	C	Pack.
00513 RO		4.5	22	24.5	10
00513 BL		4.5	22	24.5	10

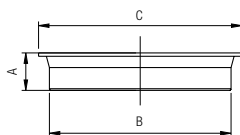

Dimensioni sede per presa 511
Seat dimensions for 511 socket
Einbaumasse für Kupplung 511
Dimensions pour coupleur 511
Dimensiones para la sede enchufe 511
Dimensões da sede para soquete 511

Size	D	P	F
1/8	22	22	6
1/4	22	21.5	8
3/8	22	21.5	9

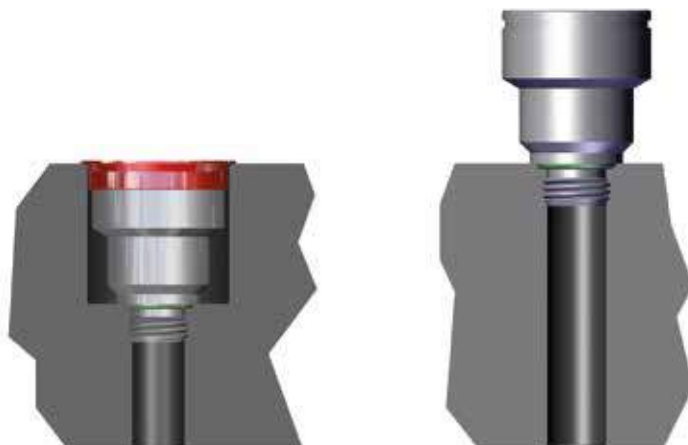

SERIE 420-520 FRENCH PROFILE DN12

422

INNESTO CON ATTACCO FEMMINA

FEMALE PLUG
 STECKER MIT INNENGEWINDE
 EMBOUT FEMELLE
 ADAPTADOR HEMBRA
 PLUG COM ROSCA FÊMEA

Code	A	B	C	D	L	CH	Pack.
00422 00 001	1/2	15	38.5	28	58	24	10

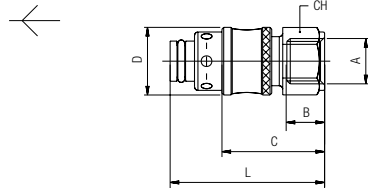

425

INNESTO CON PORTAGOMMA DIRITTO

STRAIGHT PLUG WITH REST FOR RUBBER HOSE
 STECKER MIT SCHLAUCHTÜLLE
 EMBOUT À DOUILLE ANNELÉE
 ADAPTADOR CON PORTAGOMA RECTO
 PLUG COM ESPIGÃO PARA TUBO DE BORRACHA RETO

Code	A	B	C	D	L	Pack.
00425 00 001	13	33	55	28	75	10
00425 00 002	16	33	55	28	75	10

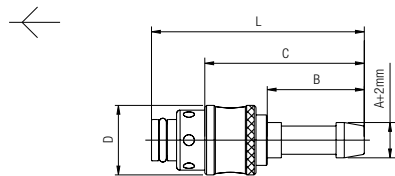

521

PRESA CON ATTACCO MASCHIO

MALE SOCKET
 VERSCHLUSS-KUPPLUNG MIT AUSSENGEWINDE
 COUPLEUR MÂLE
 ENCHUFE MACHO
 SOQUETE COM ROSCA MACHO

Code	A	B	C	L	CH	Pack.
00521 00 001	3/8	9	32	37.5	10	10
00521 00 002	1/2	10	32	38	12	10

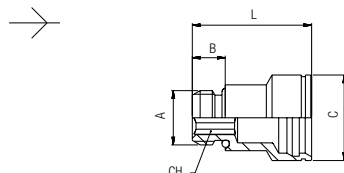

522

PRESA CON ATTACCO MASCHIO CONICO

MALE SOCKET TAPER
 VERSCHLUSS-KUPPLUNG MIT AUSSENGEWINDE KONISCH
 COUPLEUR MALE CONIQUE
 ENCHUFE MACHO CÓNICO
 SOQUETE COM ROSCA MACHO

Code	A	B	C	L	CH	Pack.
00522 00 01 04 TF	3/8	11.5	32	39.5	10	10
00522 00 01 05 TF	1/2	14	32	41	12	10

FILETTO PRE SIGILLATO
 PRE-COATING THREAD
 GEWINDE BESCHICHTET
 PRÉ-COATING
 ROSCA PRESELLADA
 ROSCA TEFLONADA

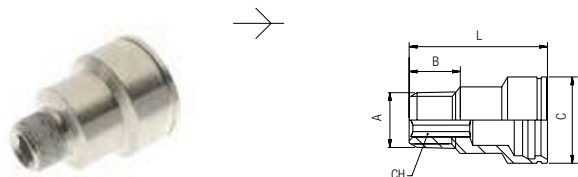

523

ANELLO DI RICONOSCIMENTO

IDENTIFICATION RING
 KENNZEICHNUNGSRING
 ANNEAU D'IDENTIFICATION
 ANILLO DE IDENTIFICACIÓN
 ANEL DE IDENTIFICAÇÃO

Code	Color	A	B	C	Pack.
00523 RO	Red	4.5	33	36	10
00523 BL	Blue	4.5	33	36	10



Dimensioni sede per presa 521
 Seat dimensions for 521 socket
 Einbaumasse für Kupplung 521
 Dimensions pour coupleur 521
 Dimensiones para la sede enchufe 521
 Dimensões da sede para soquete 521

Size	D	P	F
3/8	33	29	9
1/2	33	28.5	10

