

## REGOLATORI DI PORTATA ORIENTABILI

ORIENTING FLOW REGULATOR  
 DURCHFLUSSREGLER (DREHBAR)  
 RÉGLEURS DE DÉBIT ORIENTABLES  
 REGULADORES DE CAUDAL ORIENTABLES  
 REGULADORAS DE VAZÃO ORIENTÁVEL



## CARATTERISTICHE TECNICHE

TECHNICAL CHARACTERISTICS  
 TECHNISCHE ANGABEN  
 CARACTÉRISTIQUES TECHNIQUES  
 CARACTERÍSTICAS TÉCNICAS  
 CARACTERÍSTICAS TÉCNICAS



## Norma di Riferimento

Reference Standard

Entspricht Der Norm

Conforme à La Norme

Normativa de Referencia

Norma de Referència

1907/2006

REACH

2011/65/CE

RoHS

PED  
2014/68/UESILICON  
FREE

## Pressioni

Pressures

Druckbereich

Pressions

Presiones

Pressões

1 bar (0.1 MPa)

10 bar (1 MPa)



## Temperature

Temperatures

Temperatur

Températures

Temperaturas

Temperaturas

- 20 °C

+ 80 °C



## Fluidi compatibili

Aria compressa

Fluids

Compressed air

Geeignete Medien

Druckluft

Fluides compatibles

Air comprimé

Fluidos compatibles

Aire comprimido

Fluidos compatíveis

Ar comprimido



## Tubi di Collegamento

IT

Tubi in materiale plastico:

PA6, PA11, PA12, Polietilene, \*Poliuretano, PTFE, FEP.

\*Per tubi in Poliuretano è consigliata una durezza di 98 shore.

## Connection Tubes

GB

Plastic tubes:

PA6, PA11, PA12, Polyethylene, \*Polyurethane, PTFE, FEP.

\*For Polyurethane hoses it is required a minimum hardness of 98 shore.

## Geeignete Rohre

DE

Kunststoffrohre:

PA6, PA11, PA12, Polyethylene, \*Polyurethan, PTFE, FEP.

\*Für Polyurethan Rohre ist eine Härte von 98 Shore empfohlen.

## Tubes Conseillés

FR

Tubes plastiques:

PA6, PA11, PA12, Polyéthylène, \*Polyuréthane, PTFE, FEP.

\*Pour les tubes en polyuréthane, il est conseillé une dureté de 98 Shore.

## Tubos de Conexión

ES

Tubos en material plástico:

PA6, PA11, PA12, Polietileno, \*Poliuretano, PTFE, FEP.

\*Para tubos en poliuretano es aconsejada una dureza de 98 shore.

## Tubos de Conexão

PT

Tubos em material plástico:

PA6, PA11, PA12, Polietileno, \*Poliuretano, PTFE, FEP.

\*Para tubos em Poliuretano é requerida uma dureza de 98 shore.

**C**

**UNIDIREZIONALE PER CILINDRO**

UNI-DIRECTIONAL FOR CYLINDER

DROSSELUNG FÜR ZYLINDER (ABLUFT)

UNIDIRECTIONNEL À L'ÉCHAPPEMENT

UNIDIRECCIONAL PARA CILINDRO

UNIDIRECCIONAL PARA CILINDRO

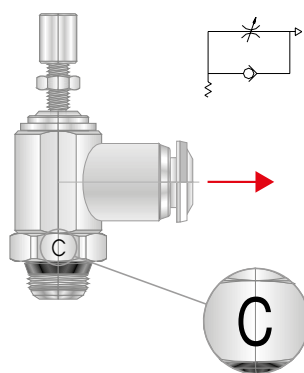

**CODE:**

50901 - 55900 - 56900 - 57901

50905 - 55905 - 56905 - 57905

55902

55906

**V**

**UNIDIREZIONALE PER VAVOLA**

UNI-DIRECTIONAL FOR VALVE

DROSSELUNG FÜR VENTILE (ZULUFT)

UNIDIRECTIONNEL À L'ADMISSION

UNIDIRECCIONAL PARA VÁLVULA

UNIDIRECCIONAL PARA VÁLVULA

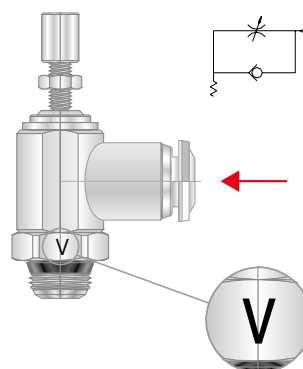

**CODE:**

50910 - 55910 - 56910 - 57910

50915 - 55915 - 56915 - 57915

55912

55916

**B**

**BIDIREZIONALE**

BI-DIRECTIONAL

BI-DIREKTIONAL (OHNE RÜCKSCHLAG)

BI-DIRECTIONNEL

BIDIRECCIONAL

BI-DIRECCIONAL

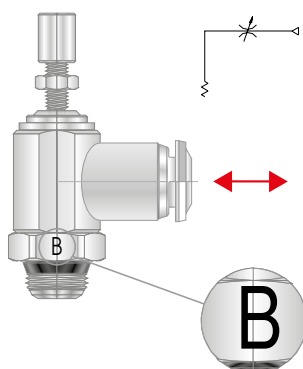

**CODE:**

50920 - 55920 - 56920 - 57920

50925 - 55925 - 56925 - 57925

55922

55926

LEGENDA  
KEY  
LEGENDE  
LEGENDE  
LEYENDA  
LEGENDA



Regolazione a cacciavite - Screwdriver regulation - Einstellbar mit schraubenzieher  
A vis noyée - Regulación a destornillador - Regulagem por parafuso



Regolazione manuale - Manual regulation - Einstellbar von hand  
Réglage manuel - Regulación manual - Regulagem manual



<b>Filettatura</b> <b>IT</b> Filettatura "UNIVERSAL SHORT". Metrica conforme ISO R/262. Gas cilindrica conforme ISO 228 Classe A.	<b>Threads</b> <b>GB</b> "UNIVERSAL SHORT" Threads. Metric in conformity with ISO R/262. Parallel gas in conformity with ISO 228 Class A.	<b>Gewindearten</b> <b>DE</b> Gewinde "UNIVERSAL SHORT". Metrisches Gewinde nach Norm ISO R/262. Zylindrisches Gewinde nach Norm ISO 228 Classe A.
<b>Filetages</b> <b>FR</b> Filetage "UNIVERSAL SHORT". Filetage métrique conforme ISO R/262. Filetage cylindrique conforme ISO 228 Class A.	<b>Roscas</b> <b>ES</b> Rosca "UNIVERSAL SHORT". Métrica conforme ISO R/262. Gas cilíndrica conforme ISO 228 Clase A.	<b>Roscas</b> <b>PT</b> Rosca "UNIVERSAL SHORT". Métrica conforme ISO R/262. Gas paralela conforme ISO 228 Classe A.



**UNIVERSAL SHORT**

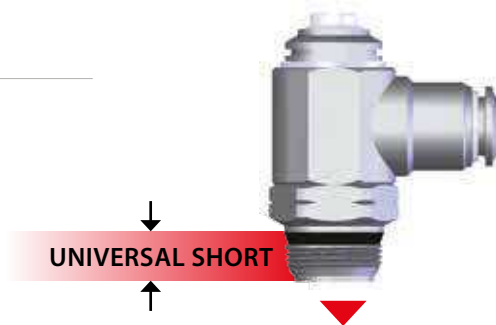

 <b>NPT</b> <b>NPTF</b> Conica Tapered Konisch Conique Cónica Cônica	 <b>ISO 7</b> <b>BSPP</b> Cilindrica Parallell Zylindrisch Cylindrique Cilindrica Paralela	 <b>ISO 7</b> <b>BSPT</b> <b>PT</b> Conica Tapered Konisch Conique Cónica Cônica	 <b>ISO 228</b> <b>BSP</b> <b>PF</b> Cilindrica Parallell Zylindrisch Cylindrique Cilindrica Paralela
--	--	---	--

<b>"UNIVERSAL SHORT"</b> <b>IT</b> La filettatura conica "UNIVERSAL SHORT" è progettata per soddisfare le seguenti caratteristiche: <ul style="list-style-type: none"> <li>• ridurre la lunghezza d'ingombro;</li> <li>• ridurre la chiave rispetto ad alcuni regolatori con filettature cilindriche;</li> <li>• consentire l'accoppiamento con diversi standard di filettature femmina sia coniche che cilindriche.</li> </ul>	<b>"UNIVERSAL SHORT"</b> <b>GB</b> The "UNIVERSAL SHORT" taper thread has been designed to offer the following advantages to the users: <ul style="list-style-type: none"> <li>• reduced overall length;</li> <li>• smaller hex dimensions compared to the parallel threads;</li> <li>• to allow the assembly with different female threads both taper as well as parallel.</li> </ul>	<b>"UNIVERSAL SHORT"</b> <b>DE</b> Das konische Gewinde "UNIVERSAL SHORT" ist so konzipiert, dass folgende Vorteile erzielt werden: <ul style="list-style-type: none"> <li>• Reduzierung der Länge des Gewindes - kürzere Montagezeit;</li> <li>• Reduzierung der Schlüsselweite im Vergleich von Durchflussregler mit zylindrischen Gewinden - geringerer Lochabstand</li> <li>• Ermöglicht den Einsatz in verschiedene Gewindearten, sowie in konische- und zylindrische Innengewinde.</li> </ul>
---	--	---

<b>"UNIVERSAL SHORT"</b> <b>FR</b> Le filetage conique "UNIVERSAL SHORT" a été conçu pour satisfaire les exigences suivantes: <ul style="list-style-type: none"> <li>• réduire la longueur d'encombrement;</li> <li>• réduire les dimensions hexagonales par rapport au filetage cylindrique;</li> <li>• permettre le montage avec divers taraudages standards soit coniques soit cylindriques.</li> </ul>	<b>"UNIVERSAL SHORT"</b> <b>ES</b> La rosca cónica "UNIVERSAL SHORT" ha sido proyectada para satisfacer las siguientes características: <ul style="list-style-type: none"> <li>• reducir la longitud;</li> <li>• reducir la llave respecto a algunos reguladores con rosca cilíndrica;</li> <li>• consentir el acoplamiento con diferentes standard de rosca hembra sean cónicas o cilíndricas.</li> </ul>	<b>"UNIVERSAL SHORT"</b> <b>PT</b> A rosca cônica "UNIVERSAL SHORT" é projetada para satisfazer às seguintes características: <ul style="list-style-type: none"> <li>• reduzir o comprimento da conexão;</li> <li>• reduzir o dimensional com relação às rosca paralelas;</li> <li>• permitir o acoplamento da conexão a diferentes tipos de rosca fêmea, sejam elas cónicas ou paralelas.</li> </ul>
--	--	---



**Inclinate**  
 Inclined  
 Geneigt  
 Incliné  
 Inclinada  
 Inclinadas



**Concave**  
 Concave  
 Konkav  
 Concave  
 Cóncava  
 Côncavas



**Convexe**  
 Convex  
 Konvex  
 Convexe  
 Convexa  
 Convexas

<b>IT</b> Consentire una completa tenuta anche su superfici non perfettamente piane, concave, convesse o inclinate, con diversi smussi o raggi.	<b>GB</b> To ensure the right tightening also with surfaces not perfectly flat, without spot-facing, concave convex and with different kinds of chamfers or radius.	<b>DE</b> Eine vollständige Abdichtung ist auch auf unebenen Flächen, wie geneigt, konkav oder konvex und mit unterschiedlichen Radien oder Fasen gewährleistet.
--	--	---

<b>FR</b> Pour permettre une parfaite étanchéité même sur des surfaces non planes, concaves, convexas ou inclinées et avec différents chanfreins ou rayons.	<b>ES</b> Consentir una completa estanqueidad incluso en superficies no perfectamente planas, cóncavas, convexas o inclinadas, con diferentes ángulos o radios.	<b>PT</b> Permite um aperto correto em superfícies não perfeitamente planas, cóncavas, convexas ou inclinadas, com diferentes chanfros ou raios.
--	--	---

## 50901

## REGOLATORE UNIDIREZIONALE ORIENTABILE PER CILINDRO "UNIVERSAL SHORT"

ORIENTING FLOW REGULATOR FOR CYLINDER "UNIVERSAL SHORT"

DURCHFLOSSREGLER ABLUFTDROSSELUNG (DREHBAR) "UNIVERSAL SHORT"

RÉGLEUR DE DÉBIT À L'ÉCHAPPEMENT FILETAGE (ORIENTABLE) "UNIVERSAL SHORT"

REGULADOR UNIDIRECCIONAL ORIENTABLE PARA CILINDRO "UNIVERSAL SHORT"

REGULADORA UNIDIRECCIONAL ORIENTÁVEL PARA CILINDRO ROSCA "UNIVERSAL SHORT"

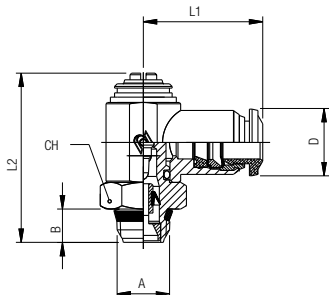
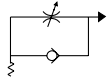

Code	Tube	A	B	L1	L2	CH	D	Pack.
50901 00 001	3	M5	4	19	29.5	8	10	10
50901 00 002	4	M5	4	19	29.5	8	10	10
50901 00 003	4	1/8	5.5	21	31	14	10	10
50901 00 004	5	M5	4	20	29.5	8	12.5	10
50901 00 005	5	1/8	5.5	21.5	31	14	12.5	10
50901 00 006	5	1/4	7	24.5	36.5	17	12.5	10
50901 00 007	6	M5	4	20.5	29.5	8	12.5	10
50901 00 008	6	1/8	5.5	22.5	31	14	12.5	10
50901 00 009	6	1/4	7	25	36.5	17	12.5	10
50901 00 010	8	1/8	5.5	24	31	14	14	10
50901 00 011	8	1/4	7	26	36.5	17	14	10
50901 00 016	8	3/8	7.5	28.5	42.5	20	14	10
50901 00 017	10	1/4	7	28.5	36.5	17	17	10
50901 00 012	10	3/8	7.5	30.5	42.5	20	17	10
50901 00 013	12	3/8	7.5	32.5	42.5	20	21.5	10
50901 00 014	12	1/2	9	35	47	24	21.5	10
50901 00 015	14	1/2	9	35.5	47	24	21.5	10

## 50910

## REGOLATORE UNIDIREZIONALE ORIENTABILE PER VALVOLA "UNIVERSAL SHORT"

ORIENTING FLOW REGULATOR FOR VALVE "UNIVERSAL SHORT"

DURCHFLOSSREGLER ZULUFTDROSSELUNG (DREHBAR) "UNIVERSAL SHORT"

RÉGLEUR DE DÉBIT À L'ADMISSION FILETAGE (ORIENTABLE) "UNIVERSAL SHORT"

REGULADOR UNIDIRECCIONAL ORIENTABLE PARA VÁLVULA "UNIVERSAL SHORT"

REGULADORA UNIDIRECCIONAL ORIENTÁVEL PARA VÁLVULA ROSCA "UNIVERSAL SHORT"

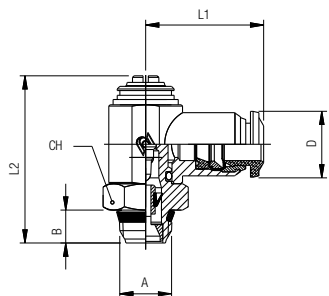
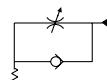

Code	Tube	A	B	L1	L2	CH	D	Pack.
50910 00 001	3	M5	4	19	29.5	8	10	10
50910 00 002	4	M5	4	19	29.5	8	10	10
50910 00 003	4	1/8	5.5	21	31	14	10	10
50910 00 004	5	M5	4	20	29.5	8	12.5	10
50910 00 005	5	1/8	5.5	21.5	31	14	12.5	10
50910 00 006	5	1/4	7	24.5	36.5	17	12.5	10
50910 00 007	6	M5	4	20.5	29.5	8	12.5	10
50910 00 008	6	1/8	5.5	22.5	31	14	12.5	10
50910 00 009	6	1/4	7	25	36.5	17	12.5	10
50910 00 010	8	1/8	5.5	24	31	14	14	10
50910 00 011	8	1/4	7	26	36.5	17	14	10
50910 00 016	8	3/8	7.5	28.5	42.5	20	14	10
50910 00 017	10	1/4	7	28.5	36.5	17	17	10
50910 00 012	10	3/8	7.5	30.5	42.5	20	17	10
50910 00 013	12	3/8	7.5	32.5	42.5	20	21.5	10
50910 00 014	12	1/2	9	35	47	24	21.5	10
50910 00 015	14	1/2	9	35.5	47	24	21.5	10

## 50920

## REGOLATORE BIDIREZIONALE ORIENTABILE "UNIVERSAL SHORT"

ORIENTING BI-DIRECTIONAL FLOW REGULATOR "UNIVERSAL SHORT"

DURCHFLOSSREGLER BI-DIREKTIONAL (DREHBAR) "UNIVERSAL SHORT"

RÉGLEUR DE DÉBIT BI-DIRECTIONNEL FILETAGE (ORIENTABLE) "UNIVERSAL SHORT"

REGULADOR BIDIRECCIONAL ORIENTABLE "UNIVERSAL SHORT"

REGULADORA BI-DIRECCIONAL ORIENTÁVEL ROSCA "UNIVERSAL SHORT"

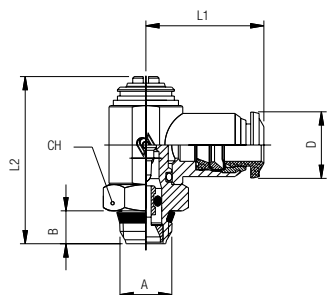

Code	Tube	A	B	L1	L2	CH	D	Pack.
50920 00 001	3	M5	4	19	29.5	8	10	10
50920 00 002	4	M5	4	19	29.5	8	10	10
50920 00 003	4	1/8	5.5	21	31	14	10	10
50920 00 004	5	M5	4	20	29.5	8	12.5	10
50920 00 005	5	1/8	5.5	21.5	31	14	12.5	10
50920 00 006	5	1/4	7	24.5	36.5	17	12.5	10
50920 00 007	6	M5	4	20.5	29.5	8	12.5	10
50920 00 008	6	1/8	5.5	22.5	31	14	12.5	10
50920 00 009	6	1/4	7	25	36.5	17	12.5	10
50920 00 010	8	1/8	5.5	24	31	14	14	10
50920 00 011	8	1/4	7	26	36.5	17	14	10
50920 00 016	8	3/8	7.5	28.5	42.5	20	14	10
50920 00 017	10	1/4	7	28.5	36.5	17	17	10
50920 00 012	10	3/8	7.5	30.5	42.5	20	17	10
50920 00 013	12	3/8	7.5	32.5	42.5	20	21.5	10
50920 00 014	12	1/2	9	35	47	24	21.5	10
50920 00 015	14	1/2	9	35.5	47	24	21.5	10

## 50905

## REGOLATORE UNIDIREZIONALE ORIENTABILE PER CILINDRO "UNIVERSAL SHORT"

ORIENTING FLOW REGULATOR FOR CYLINDER "UNIVERSAL SHORT"

DURCHFLOSSREGLER ABLUFTDROSSELUNG (DREHBAR) "UNIVERSAL SHORT"

RÉGLEUR DE DÉBIT À L'ÉCHAPPEMENT FILETAGE (ORIENTABLE) "UNIVERSAL SHORT"

REGULADOR UNIDIRECCIONAL ORIENTABLE PARA CILINDRO "UNIVERSAL SHORT"

REGULADORA UNIDIRECCIONAL ORIENTÁVEL PARA CILINDRO ROSCA "UNIVERSAL SHORT"

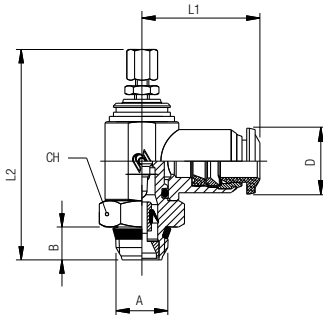
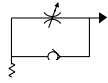

Code	Tube	A	B	L1	L2 min	L2 max	CH	D	Pack.
50905 00 001	3	M5	4	19	39.5	43.5	8	10	10
50905 00 002	4	M5	4	19	39.5	43.5	8	10	10
50905 00 003	4	1/8	5.5	21	44	49	14	10	10
50905 00 004	5	M5	4	20	39.5	43.5	8	12.5	10
50905 00 005	5	1/8	5.5	21.5	44	49	14	12.5	10
50905 00 006	5	1/4	7	24.5	48.5	55	17	12.5	10
50905 00 007	6	M5	4	20.5	39.5	43.5	8	12.5	10
50905 00 008	6	1/8	5.5	22.5	44	49	14	12.5	10
50905 00 009	6	1/4	7	25	48.5	55	17	12.5	10
50905 00 010	8	1/8	5.5	24	44	49	14	14	10
50905 00 011	8	1/4	7	26	48.5	55	17	14	10
50905 00 016	8	3/8	7.5	28.5	56	65	20	14	10
50905 00 017	10	1/4	7	28.5	48.5	55	17	17	10
50905 00 012	10	3/8	7.5	30.5	56	65	20	17	10
50905 00 013	12	3/8	7.5	32.5	56	65	20	21.5	10
50905 00 014	12	1/2	9	35	62	69	24	21.5	10
50905 00 015	14	1/2	9	35.5	62	69	24	21.5	10

## 50915

## REGOLATORE UNIDIREZIONALE ORIENTABILE PER VALVOLA "UNIVERSAL SHORT"

ORIENTING FLOW REGULATOR FOR VALVE "UNIVERSAL SHORT"

DURCHFLOSSREGLER ZULUFTDROSSELUNG (DREHBAR) "UNIVERSAL SHORT"

RÉGLEUR DE DÉBIT À L'ADMISSION FILETAGE (ORIENTABLE) "UNIVERSAL SHORT"

REGULADOR UNIDIRECCIONAL ORIENTABLE PARA VÁLVULA "UNIVERSAL SHORT"

REGULADORA UNIDIRECCIONAL ORIENTÁVEL PARA VÁLVULA ROSCA "UNIVERSAL SHORT"

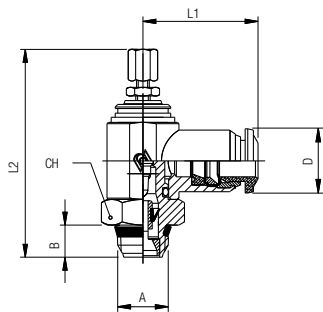
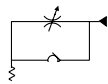

Code	Tube	A	B	L1	L2 min	L2 max	CH	D	Pack.
50915 00 001	3	M5	4	19	39.5	43.5	8	10	10
50915 00 002	4	M5	4	19	39.5	43.5	8	10	10
50915 00 003	4	1/8	5.5	21	44	49	14	10	10
50915 00 004	5	M5	4	20	39.5	43.5	8	12.5	10
50915 00 005	5	1/8	5.5	21.5	44	49	14	12.5	10
50915 00 006	5	1/4	7	24.5	48.5	55	17	12.5	10
50915 00 007	6	M5	4	20.5	39.5	43.5	8	12.5	10
50915 00 008	6	1/8	5.5	22.5	44	49	14	12.5	10
50915 00 009	6	1/4	7	25	48.5	55	17	12.5	10
50915 00 010	8	1/8	5.5	24	44	49	14	14	10
50915 00 011	8	1/4	7	26	48.5	55	17	14	10
50915 00 016	8	3/8	7.5	28.5	56	65	20	14	10
50915 00 017	10	1/4	7	28.5	48.5	55	17	17	10
50915 00 012	10	3/8	7.5	30.5	56	65	20	17	10
50915 00 013	12	3/8	7.5	32.5	56	65	20	21.5	10
50915 00 014	12	1/2	9	35	62	69	24	21.5	10
50915 00 015	14	1/2	9	35.5	62	69	24	21.5	10

## 50925

## REGOLATORE BIDIREZIONALE ORIENTABILE "UNIVERSAL SHORT"

ORIENTING BI-DIRECTIONAL FLOW REGULATOR "UNIVERSAL SHORT"

DURCHFLOSSREGLER BI-DIREKTIONAL (DREHBAR) "UNIVERSAL SHORT"

RÉGLEUR DE DÉBIT BI-DIRECTIONNEL FILETAGE (ORIENTABLE) "UNIVERSAL SHORT"

REGULADOR BIDIRECCIONAL ORIENTABLE "UNIVERSAL SHORT"

REGULADORA BI-DIRECCIONAL ORIENTÁVEL ROSCA "UNIVERSAL SHORT"

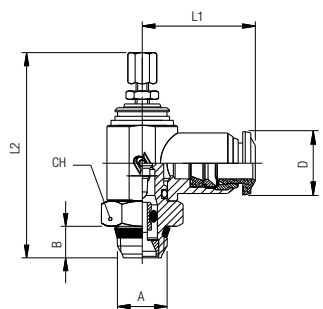

Code	Tube	A	B	L1	L2 min	L2 max	CH	D	Pack.
50925 00 001	3	M5	4	19	39.5	43.5	8	10	10
50925 00 002	4	M5	4	19	39.5	43.5	8	10	10
50925 00 003	4	1/8	5.5	21	44	49	14	10	10
50925 00 004	5	M5	4	20	39.5	43.5	8	12.5	10
50925 00 005	5	1/8	5.5	21.5	44	49	14	12.5	10
50925 00 006	5	1/4	7	24.5	48.5	55	17	12.5	10
50925 00 007	6	M5	4	20.5	39.5	43.5	8	12.5	10
50925 00 008	6	1/8	5.5	22.5	44	49	14	12.5	10
50925 00 009	6	1/4	7	25	48.5	55	17	12.5	10
50925 00 010	8	1/8	5.5	24	44	49	14	14	10
50925 00 011	8	1/4	7	26	48.5	55	17	14	10
50925 00 016	8	3/8	7.5	28.5	56	65	20	14	10
50925 00 017	10	1/4	7	28.5	48.5	55	17	17	10
50925 00 012	10	3/8	7.5	30.5	56	65	20	17	10
50925 00 013	12	3/8	7.5	32.5	56	65	20	21.5	10
50925 00 014	12	1/2	9	35	62	69	24	21.5	10
50925 00 015	14	1/2	9	35.5	62	69	24	21.5	10



## 55900

## REGOLATORE UNIDIREZIONALE ORIENTABILE PER CILINDRO "UNIVERSAL SHORT"

ORIENTING FLOW REGULATOR FOR CYLINDER "UNIVERSAL SHORT"

DURCHFLOSSREGLER ABLUFTDROSSELUNG (DREHBAR) "UNIVERSAL SHORT"

RÉGLEUR DE DÉBIT À L'ÉCHAPPEMENT FILETAGE (ORIENTABLE) "UNIVERSAL SHORT"

REGULADOR UNIDIRECCIONAL ORIENTABLE PARA CILINDRO "UNIVERSAL SHORT"

REGULADORA UNIDIRECCIONAL ORIENTÁVEL PARA CILINDRO ROSCA "UNIVERSAL SHORT"

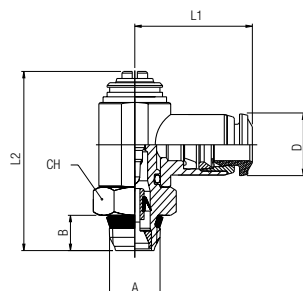
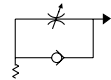

Code	Tube	A	B	L1	L2	CH	D	Pack.
55900 00 002	4	M5	5.5	19.5	29.5	8	10	10
55900 00 003	4	1/8	5.5	21.5	31	14	10	10
55900 00 004	5	M5	5.5	20.5	29.5	8	12.5	10
55900 00 005	5	1/8	5.5	22.5	31	14	12.5	10
55900 00 006	5	1/4	7	25	36.5	17	12.5	10
55900 00 007	6	M5	5.5	21	29.5	8	12.5	10
55900 00 008	6	1/8	5.5	23	31	14	12.5	10
55900 00 009	6	1/4	7	25.5	36.5	17	12.5	10
55900 00 010	8	1/8	5.5	23.5	31	14	14	10
55900 00 011	8	1/4	7	26	36.5	17	14	10
55900 00 012	8	3/8	8.5	27.5	42.5	20	14	10
55900 00 013	10	3/8	8.5	30.5	42.5	20	17	10
55900 00 014	12	3/8	8.5	32.5	42.5	20	21.5	10
55900 00 015	12	1/2	10	35	47	24	21.5	10

## 55910

## REGOLATORE UNIDIREZIONALE ORIENTABILE PER VALVOLA "UNIVERSAL SHORT"

ORIENTING FLOW REGULATOR FOR VALVE "UNIVERSAL SHORT"

DURCHFLOSSREGLER ZULUFTDROSSELUNG (DREHBAR) "UNIVERSAL SHORT"

RÉGLEUR DE DÉBIT À L'ADMISSION FILETAGE (ORIENTABLE) "UNIVERSAL SHORT"

REGULADOR UNIDIRECCIONAL ORIENTABLE PARA VÁLVULA "UNIVERSAL SHORT"

REGULADORA UNIDIRECCIONAL ORIENTÁVEL PARA VÁLVULA ROSCA "UNIVERSAL SHORT"

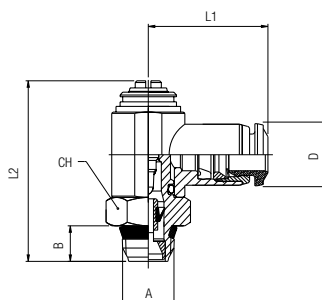
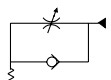

Code	Tube	A	B	L1	L2	CH	D	Pack.
55910 00 002	4	M5	4	19.5	29.5	8	10	10
55910 00 003	4	1/8	5.5	21.5	31	14	10	10
55910 00 004	5	M5	4	20.5	29.5	8	12.5	10
55910 00 005	5	1/8	5.5	22.5	31	14	12.5	10
55910 00 006	5	1/4	7	25	36.5	17	12.5	10
55910 00 007	6	M5	4	21	29.5	8	12.5	10
55910 00 008	6	1/8	5.5	23	31	14	12.5	10
55910 00 009	6	1/4	7	25.5	36.5	17	12.5	10
55910 00 010	8	1/8	5.5	23.5	31	14	14	10
55910 00 011	8	1/4	7	26	36.5	17	14	10
55910 00 012	8	3/8	8.5	27.5	42.5	20	14	10
55910 00 013	10	3/8	8.5	30.5	42.5	20	17	10
55910 00 014	12	3/8	8.5	32.5	42.5	20	21.5	10
55910 00 015	12	1/2	10	35	47	24	21.5	10

## 55920

## REGOLATORE BIDIREZIONALE ORIENTABILE "UNIVERSAL SHORT"

ORIENTING BI-DIRECTIONAL FLOW REGULATOR "UNIVERSAL SHORT"

DURCHFLOSSREGLER BI-DIREKTIONAL (DREHBAR) "UNIVERSAL SHORT"

RÉGLEUR DE DÉBIT BI-DIRECTIONNEL FILETAGE (ORIENTABLE) "UNIVERSAL SHORT"

REGULADOR BIDIRECCIONAL ORIENTABLE "UNIVERSAL SHORT"

REGULADORA BI-DIRECCIONAL ORIENTÁVEL ROSCA "UNIVERSAL SHORT"

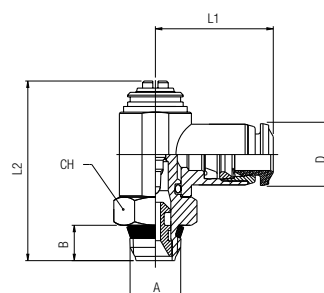

Code	Tube	A	B	L1	L2	CH	D	Pack.
55920 00 002	4	M5	4	19.5	29.5	8	10	10
55920 00 003	4	1/8	5.5	21.5	31	14	10	10
55920 00 004	5	M5	4	20.5	29.5	8	12.5	10
55920 00 005	5	1/8	5.5	22.5	31	14	12.5	10
55920 00 006	5	1/4	7	25	36.5	17	12.5	10
55920 00 007	6	M5	4	21	29.5	8	12.5	10
55920 00 008	6	1/8	5.5	23	31	14	12.5	10
55920 00 009	6	1/4	7	25.5	36.5	17	12.5	10
55920 00 010	8	1/8	5.5	23.5	31	14	14	10
55920 00 011	8	1/4	7	26	36.5	17	14	10
55920 00 012	8	3/8	8.5	27.5	42.5	20	14	10
55920 00 013	10	3/8	8.5	30.5	42.5	20	17	10
55920 00 014	12	3/8	8.5	32.5	42.5	20	21.5	10
55920 00 015	12	1/2	10	35	47	24	21.5	10

## 55905

## REGOLATORE UNIDIREZIONALE ORIENTABILE PER CILINDRO "UNIVERSAL SHORT"

ORIENTING FLOW REGULATOR FOR CYLINDER "UNIVERSAL SHORT"

DURCHFLOSSREGLER ABLUFTDROSSELUNG (DREHBAR) "UNIVERSAL SHORT"

RÉGLEUR DE DÉBIT À L'ÉCHAPPEMENT FILETAGE (ORIENTABLE) "UNIVERSAL SHORT"

REGULADOR UNIDIRECCIONAL ORIENTABLE PARA CILINDRO "UNIVERSAL SHORT"

REGULADORA UNIDIRECCIONAL ORIENTÁVEL PARA CILINDRO ROSCA "UNIVERSAL SHORT"

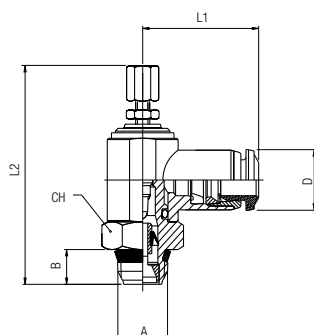
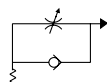

Code	Tube	A	B	L1	L2 min	L2 max	CH	D	Pack.
55905 00 002	4	M5	4	19.5	39.5	43.5	8	10	10
55905 00 003	4	1/8	5.5	21.5	44	49	14	10	10
55905 00 004	5	M5	4	20.5	39.5	43.5	8	12.5	10
55905 00 005	5	1/8	5.5	22.5	44	49	14	12.5	10
55905 00 006	5	1/4	7	25	48.5	55	17	12.5	10
55905 00 007	6	M5	4	21	39.5	43.5	8	12.5	10
55905 00 008	6	1/8	5.5	23	44	49	14	12.5	10
55905 00 009	6	1/4	7	25.5	48.5	55	17	12.5	10
55905 00 010	8	1/8	5.5	23.5	44	49	14	14	10
55905 00 011	8	1/4	7	26	48.5	55	17	14	10
55905 00 012	8	3/8	8.5	27.5	56	65	20	14	10
55905 00 013	10	3/8	8.5	30.5	56	65	20	17	10
55905 00 014	12	3/8	8.5	32.5	56	65	20	21.5	10
55905 00 015	12	1/2	10	35	62	69	24	21.5	10

## 55915

## REGOLATORE UNIDIREZIONALE ORIENTABILE PER VALVOLA "UNIVERSAL SHORT"

ORIENTING FLOW REGULATOR FOR VALVE "UNIVERSAL SHORT"

DURCHFLOSSREGLER ZULUFTDROSSELUNG (DREHBAR) "UNIVERSAL SHORT"

RÉGLEUR DE DÉBIT À L'ADMISSION FILETAGE (ORIENTABLE) "UNIVERSAL SHORT"

REGULADOR UNIDIRECCIONAL ORIENTABLE PARA VÁLVULA "UNIVERSAL SHORT"

REGULADORA UNIDIRECCIONAL ORIENTÁVEL PARA VÁLVULA ROSCA "UNIVERSAL SHORT"

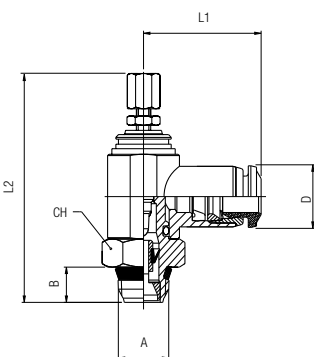
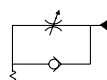

Code	Tube	A	B	L1	L2 min	L2 max	CH	D	Pack.
55915 00 002	4	M5	4	19.5	39.5	43.5	8	10	10
55915 00 003	4	1/8	5.5	21.5	44	49	14	10	10
55915 00 004	5	M5	4	20.5	39.5	43.5	8	12.5	10
55915 00 005	5	1/8	5.5	22.5	44	49	14	12.5	10
55915 00 006	5	1/4	7	25	48.5	55	17	12.5	10
55915 00 007	6	M5	4	21	39.5	43.5	8	12.5	10
55915 00 008	6	1/8	5.5	23	44	49	14	12.5	10
55915 00 009	6	1/4	7	25.5	48.5	55	17	12.5	10
55915 00 010	8	1/8	5.5	23.5	44	49	14	14	10
55915 00 011	8	1/4	7	26	48.5	55	17	14	10
55915 00 012	8	3/8	8.5	27.5	56	65	20	14	10
55915 00 013	10	3/8	8.5	30.5	56	65	20	17	10
55915 00 014	12	3/8	8.5	32.5	56	65	20	21.5	10
55915 00 015	12	1/2	10	35	62	69	24	21.5	10

## 55925

## REGOLATORE BIDIREZIONALE ORIENTABILE "UNIVERSAL SHORT"

ORIENTING BI-DIRECTIONAL FLOW REGULATOR "UNIVERSAL SHORT"

DURCHFLOSSREGLER BI-DIREKTIONAL (DREHBAR) "UNIVERSAL SHORT"

RÉGLEUR DE DÉBIT BI-DIRECTIONNEL FILETAGE (ORIENTABLE) "UNIVERSAL SHORT"

REGULADOR BIDIRECCIONAL ORIENTABLE "UNIVERSAL SHORT"

REGULADORA BI-DIRECCIONAL ORIENTÁVEL ROSCA "UNIVERSAL SHORT"

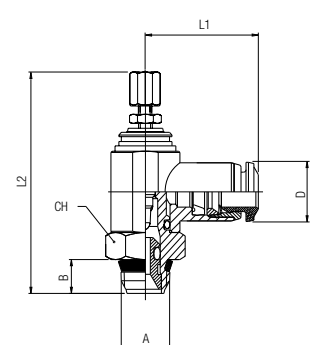
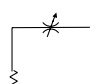

Code	Tube	A	B	L1	L2 min	L2 max	CH	D	Pack.
55925 00 002	4	M5	4	19.5	39.5	43.5	8	10	10
55925 00 003	4	1/8	5.5	21.5	44	49	14	10	10
55925 00 004	5	M5	4	20.5	39.5	43.5	8	12.5	10
55925 00 005	5	1/8	5.5	22.5	44	49	14	12.5	10
55925 00 006	5	1/4	7	25	48.5	55	17	12.5	10
55925 00 007	6	M5	4	21	39.5	43.5	8	12.5	10
55925 00 008	6	1/8	5.5	23	44	49	14	12.5	10
55925 00 009	6	1/4	7	25.5	48.5	55	17	12.5	10
55925 00 010	8	1/8	5.5	23.5	44	49	14	14	10
55925 00 011	8	1/4	7	26	48.5	55	17	14	10
55925 00 012	8	3/8	8.5	27.5	56	65	20	14	10
55925 00 013	10	3/8	8.5	30.5	56	65	20	17	10
55925 00 014	12	3/8	8.5	32.5	56	65	20	21.5	10
55925 00 015	12	1/2	10	35	62	69	24	21.5	10

**55902****REGOLATORE UNIDIREZIONALE ORIENTABILE PER CILINDRO FILETTO CILINDRICO**

ORIENTING FLOW REGULATOR FOR CYLINDER (PARALLEL)

DURCHFLOUSSREGLER ABLUFTDROSSELUNG (DREHBAR) MIT ZYL. GEWINDE

RÉGLEUR A L'ÉCHAPPEMENT FILETAGE CYLINDRIQUE

REGULADOR UNIDIRECCIONAL ORIENTABLE PARA CILINDRO ROSCA CILÍNDRICA

REGULADORA PARA CILINDRO UNIDIRECCIONAL ORIENTÁVEL COM ROSCA PARALELA

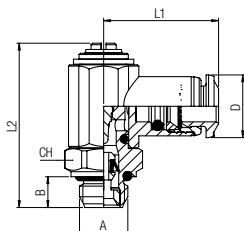
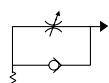

Code	Tube	A	B	L1	L2	CH	D	Pack.
55902 00 003	4	1/8	5,5	21,5	31	14	10	10
55902 00 008	6	1/8	5,5	23	31	14	12,5	10
55902 00 009	6	1/4	5,5	25,5	36,5	17	12,5	10
55902 00 010	8	1/8	5,5	23,5	31	14	14	10
55902 00 011	8	1/4	7	26	36,5	17	14	10
55902 00 012	8	3/8	8	27	42,5	20	14	10
55902 00 013	10	3/8	8	30	42,5	20	17	10
55902 00 014	12	3/8	8	32	42,5	20	21,5	10
55902 00 015	12	1/2	9,5	34,5	47	24	21,5	10

**New****55912****REGOLATORE UNIDIREZIONALE ORIENTABILE PER VALVOLA FILETTO CILINDRICO**

ORIENTING FLOW REGULATOR FOR VALVE (PARALLEL)

DURCHFLOUSSREGLER ZULUFTDROSSELUNG (DREHBAR) MIT ZYL. GEWINDE

RÉGLEUR A L'ADMISSION FILETAGE CYLINDRIQUE

REGULADOR UNIDIRECCIONAL ORIENTABLE PARA VÁLVULA ROSCA CILÍNDRICA

REGULADORA PARA VÁLVULA UNIDIRECCIONAL ORIENTÁVEL COM ROSCA PARALELA

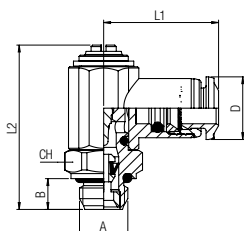
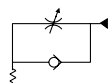

Code	Tube	A	B	L1	L2	CH	D	Pack.
55912 00 003	4	1/8	5,5	21,5	31	14	10	10
55912 00 008	6	1/8	5,5	23	31	14	12,5	10
55912 00 009	6	1/4	5,5	25,5	36,5	17	12,5	10
55912 00 010	8	1/8	5,5	23,5	31	14	14	10
55912 00 011	8	1/4	7	26	36,5	17	14	10
55912 00 012	8	3/8	8	27	42,5	20	14	10
55912 00 013	10	3/8	8	30	42,5	20	17	10
55912 00 014	12	3/8	8	32	42,5	20	21,5	10
55912 00 015	12	1/2	9,5	34,5	47	24	21,5	10

**New****55922****REGOLATORE BIDIREZIONALE ORIENTABILE FILETTO CILINDRICO**

ORIENTING BI-DIRECTIONAL FLOW REGULATOR (PARALLEL)

DURCHFLOUSSREGLER BI-DIREKTIONAL (DREHBAR) MIT ZYL. GEWINDE

RÉGLEUR BI-DIRECTIONNEL FILETAGE CYLINDRIQUE

REGULADOR BIDIRECCIONAL ORIENTABLE ROSCA CILÍNDRICA

REGULADORA BI-DIRECCIONAL ORIENTÁVEL COM ROSCA PARALELA

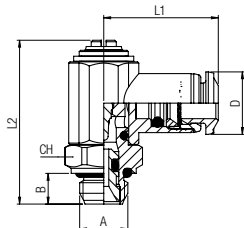

Code	Tube	A	B	L1	L2	CH	D	Pack.
55922 00 003	4	1/8	5,5	21,5	31	14	10	10
55922 00 008	6	1/8	5,5	23	31	14	12,5	10
55922 00 009	6	1/4	5,5	25,5	36,5	17	12,5	10
55922 00 010	8	1/8	5,5	23,5	31	14	14	10
55922 00 011	8	1/4	7	26	36,5	17	14	10
55922 00 012	8	3/8	8	27	42,5	20	14	10
55922 00 013	10	3/8	8	30	42,5	20	17	10
55922 00 014	12	3/8	8	32	42,5	20	21,5	10
55922 00 015	12	1/2	9,5	34,5	47	24	21,5	10

**New**



**55906****REGOLATORE UNIDIREZIONALE ORIENTABILE PER CILINDRO FILETTO CILINDRICO**

ORIENTING FLOW REGULATOR FOR CYLINDER (PARALLEL)

DURCHFLUSSREGLER ABLUFTDROSSELUNG (DREHBAR) MIT ZYL. GEWINDE

RÉGLEUR A L'ÉCHAPPEMENT FILETAGE CYLINDRIQUE

REGULADOR UNIDIRECCIONAL ORIENTABLE PARA CILINDRO ROSCA CILÍNDRICA

REGULADORA PARA CILINDRO UNIDIRECCIONAL ORIENTÁVEL COM ROSCA PARALELA

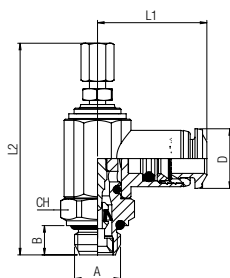
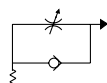
**New**

Code	Tube	A	B	L1	L2	CH	D	Pack.
55906 00 009	6	1/4	5,5	25,5	36,5	17	12,5	10
55906 00 010	8	1/8	5,5	23,5	31	14	14	10
55906 00 011	8	1/4	7	26	36,5	17	14	10
55906 00 012	8	3/8	8	27	42,5	20	14	10
55906 00 013	10	3/8	8	30	42,5	20	17	10
55906 00 014	12	3/8	8	32	42,5	20	21,5	10
55906 00 015	12	1/2	9,5	34,5	47	24	21,5	10

**55916****REGOLATORE UNIDIREZIONALE ORIENTABILE PER VALVOLA FILETTO CILINDRICO**

ORIENTING FLOW REGULATOR FOR VALVE (PARALLEL)

DURCHFLUSSREGLER ZULUFTDROSSELUNG (DREHBAR) MIT ZYL. GEWINDE

RÉGLEUR A L'ADMISSION FILETAGE CYLINDRIQUE

REGULADOR UNIDIRECCIONAL ORIENTABLE PARA VÁLVULA ROSCA CILÍNDRICA

REGULADORA PARA VÁLVULA UNIDIRECCIONAL ORIENTÁVEL COM ROSCA PARALELA

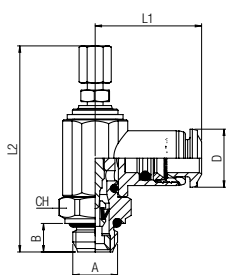
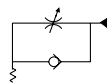
**New**

Code	Tube	A	B	L1	L2	CH	D	Pack.
55916 00 009	6	1/4	5,5	25,5	36,5	17	12,5	10
55916 00 010	8	1/8	5,5	23,5	31	14	14	10
55916 00 011	8	1/4	7	26	36,5	17	14	10
55916 00 012	8	3/8	8	27	42,5	20	14	10
55916 00 013	10	3/8	8	30	42,5	20	17	10
55916 00 014	12	3/8	8	32	42,5	20	21,5	10
55916 00 015	12	1/2	9,5	34,5	47	24	21,5	10

**55926****REGOLATORE BIDIREZIONALE ORIENTABILE FILETTO CILINDRICO**

ORIENTING BI-DIRECTIONAL FLOW REGULATOR (PARALLEL)

DURCHFLUSSREGLER BI-DIREKTIONAL (DREHBAR) MIT ZYL. GEWINDE

RÉGLEUR BI-DIRECTIONNEL FILETAGE CYLINDRIQUE

REGULADOR BIDIRECCIONAL ORIENTABLE ROSCA CILÍNDRICA

REGULADORA BI-DIRECCIONAL ORIENTÁVEL COM ROSCA PARALELA

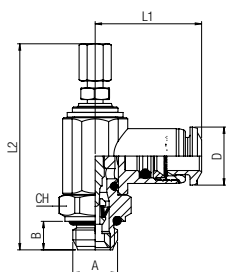
**New**

Code	Tube	A	B	L1	L2	CH	D	Pack.
55926 00 009	6	1/4	5,5	25,5	36,5	17	12,5	10
55926 00 010	8	1/8	5,5	23,5	31	14	14	10
55926 00 011	8	1/4	7	26	36,5	17	14	10
55926 00 012	8	3/8	8	27	42,5	20	14	10
55926 00 013	10	3/8	8	30	42,5	20	17	10
55926 00 014	12	3/8	8	32	42,5	20	21,5	10
55926 00 015	12	1/2	9,5	34,5	47	24	21,5	10

**56900****REGOLATORE UNIDIREZIONALE ORIENTABILE PER CILINDRO FILETTO CILINDRICO**

ORIENTING FLOW REGULATOR FOR CYLINDER (PARALLEL)

DURCHFLUSSREGLER ABLUFTDROSSELUNG (DREHBAR) MIT ZYL. GEWINDE

RÉGLEUR A L'ÉCHAPPEMENT FILETAGE CYLINDRIQUE

REGULADOR UNIDIRECCIONAL ORIENTABLE PARA CILINDRO ROSCA CILÍNDRICA

REGULADORA PARA CILINDRO UNIDIRECCIONAL ORIENTÁVEL COM ROSCA PARALELA

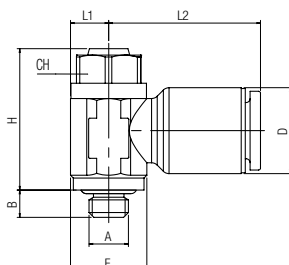
**New**

Code	Tube	A	B	H	E	L1	L2	D	CH	Pack.
56900 00 001	4	M5	3,6	18	9,5	4,5	16,5	8,5	8	10
56900 00 002	6	M5	3,6	18	9,5	4,5	19	10,5	8	10

**56910****REGOLATORE UNIDIREZIONALE ORIENTABILE PER VALVOLA FILETTO CILINDRICO**

ORIENTING FLOW REGULATOR FOR VALVE (PARALLEL)

DURCHFLUSSREGLER ZULUFTDROSSELUNG (DREHBAR) MIT ZYL. GEWINDE

RÉGLEUR A L'ADMISSION FILETAGE CYLINDRIQUE

REGULADOR UNIDIRECCIONAL ORIENTABLE PARA VÁLVULA ROSCA CILÍNDRICA

REGULADORA PARA VÁLVULA UNIDIRECCIONAL ORIENTÁVEL COM ROSCA PARALELA

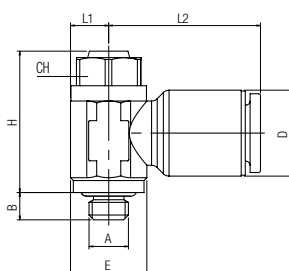
**New**

Code	Tube	A	B	H	E	L1	L2	D	CH	Pack.
56910 00 001	4	M5	3,6	18	9,5	4,5	16,5	8,5	8	10
56910 00 002	6	M5	3,6	18	9,5	4,5	19	10,5	8	10

**56920****REGOLATORE BIDIREZIONALE ORIENTABILE FILETTO CILINDRICO**

ORIENTING BI-DIRECTIONAL FLOW REGULATOR (PARALLEL)

DURCHFLUSSREGLER BI-DIREKTIONAL (DREHBAR) MIT ZYL. GEWINDE

RÉGLEUR BI-DIRECTIONNEL FILETAGE CYLINDRIQUE

REGULADOR BIDIRECCIONAL ORIENTABLE ROSCA CILÍNDRICA

REGULADORA BI-DIRECCIONAL ORIENTÁVEL COM ROSCA PARALELA

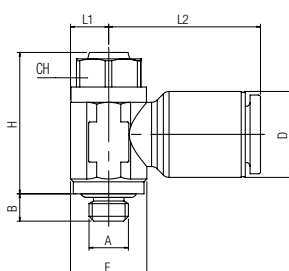
**New**

Code	Tube	A	B	H	E	L1	L2	D	CH	Pack.
56920 00 001	4	M5	3,6	18	9,5	4,5	16,5	8,5	8	10
56920 00 002	6	M5	3,6	18	9,5	4,5	19	10,5	8	10

**56935****REGOLATORE UNIDIREZIONALE ORIENTABILE PER CILINDRO FILETTO CILINDRICO**

ORIENTING FLOW REGULATOR FOR CYLINDER (PARALLEL)

DURCHFLOSSREGLER ABLUFTDROSSELUNG (DREHBAR) MIT ZYL. GEWINDE

RÉGLEUR A L'ÉCHAPPEMENT FILETAGE CYLINDRIQUE

REGULADOR UNIDIRECCIONAL ORIENTABLE PARA CILINDRO ROSCA CILÍNDRICA

REGULADORA PARA CILINDRO UNIDIRECCIONAL ORIENTÁVEL COM ROSCA PARALELA

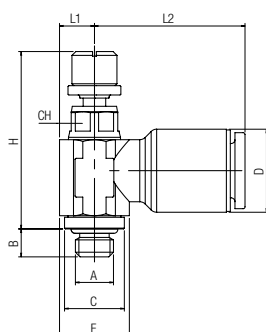
**New**

Code	Tube	A	B	H	E	C	L1	L2	D	CH	Pack.
56935 00 001	4	M5	3,6	21,5÷24,5	9	7,5	4,5	17	8,5	6	10
56935 00 002	6	M5	3,6	21,5÷24,5	9	7,5	4,5	19,5	10,5	6	10
56935 00 003	4	1/8	5	24÷27,5	11,5	13,5	6,5	17	8,5	7	10
56935 00 004	6	1/8	5	24÷27,5	11,5	13,5	6,5	19,5	10,5	7	10

**56945****REGOLATORE UNIDIREZIONALE ORIENTABILE PER VALVOLA FILETTO CILINDRICO**

ORIENTING FLOW REGULATOR FOR VALVE (PARALLEL)

DURCHFLOSSREGLER ZULUFTDROSSELUNG (DREHBAR) MIT ZYL. GEWINDE

RÉGLEUR A L'ADMISSION FILETAGE CYLINDRIQUE

REGULADOR UNIDIRECCIONAL ORIENTABLE PARA VÁLVULA ROSCA CILÍNDRICA

REGULADORA PARA VÁLVULA UNIDIRECCIONAL ORIENTÁVEL COM ROSCA PARALELA

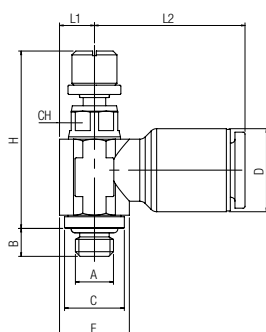
**New**

Code	Tube	A	B	H	E	C	L1	L2	D	CH	Pack.
56945 00 001	4	M5	3,6	21,5÷24,5	9	7,5	4,5	17	8,5	6	10
56945 00 002	6	M5	3,6	21,5÷24,5	9	7,5	4,5	19,5	10,5	6	10
56945 00 003	4	1/8	5	24÷27,5	11,5	13,5	6,5	17	8,5	7	10
56945 00 004	6	1/8	5	24÷27,5	11,5	13,5	6,5	19,5	10,5	7	10

**56955****REGOLATORE BIDIREZIONALE ORIENTABILE**

ORIENTING BI-DIRECTIONAL FLOW REGULATOR

DURCHFLOSSREGLER BI-DIREKTIONAL (DREHBAR)

RÉGLEUR DE DÉBIT BI-DIRECTIONNEL FILETAGE (ORIENTABLE)

REGULADOR BIDIRECCIONAL ORIENTABLE

REGULADORA BI-DIRECCIONAL ORIENTÁVEL

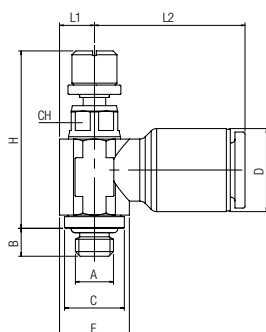
**New**

Code	Tube	A	B	H	E	C	L1	L2	D	CH	Pack.
56955 00 001	4	M5	3,6	21,5÷24,5	9	7,5	4,5	17	8,5	6	10
56955 00 002	6	M5	3,6	21,5÷24,5	9	7,5	4,5	19,5	10,5	6	10
56955 00 003	4	1/8	5	24÷27,5	11,5	13,5	6,5	17	8,5	7	10
56955 00 004	6	1/8	5	24÷27,5	11,5	13,5	6,5	19,5	10,5	7	10

## 57901

## REGOLATORE UNIDIREZIONALE ORIENTABILE PER CILINDRO "UNIVERSAL SHORT"

ORIENTING FLOW REGULATOR FOR CYLINDER "UNIVERSAL SHORT"

DURCHFLOSSREGLER ABLUFTDROSSELUNG (DREHBAR) "UNIVERSAL SHORT"

RÉGLEUR DE DÉBIT À L'ÉCHAPPEMENT FILETAGE (ORIENTABLE) "UNIVERSAL SHORT"

REGULADOR UNIDIRECCIONAL ORIENTABLE PARA CILINDRO "UNIVERSAL SHORT"

REGULADORA UNIDIRECCIONAL ORIENTÁVEL PARA CILINDRO ROSCA "UNIVERSAL SHORT"

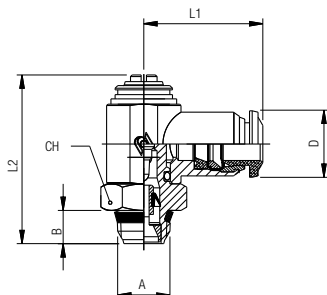
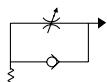

Code	Tube	A	B	L1	L2	CH	D	Pack.
57901 00 002	4	M5	4	19	29.5	8	10	10
57901 00 003	4	1/8	5.5	21	31	14	10	10
57901 00 004	5	M5	4	20	29.5	8	12.5	10
57901 00 005	5	1/8	5.5	21.5	31	14	12.5	10
57901 00 006	5	1/4	7	24.5	36.5	17	12.5	10
57901 00 007	6	M5	4	20.5	29.5	8	12.5	10
57901 00 008	6	1/8	5.5	22.5	31	14	12.5	10
57901 00 009	6	1/4	7	25	36.5	17	12.5	10
57901 00 010	8	1/8	5.5	24	31	14	14	10
57901 00 011	8	1/4	7	26	36.5	17	14	10
57901 00 016	8	3/8	7.5	28.5	42.5	20	14	10
57901 00 017	10	1/4	7	28.5	36.5	17	17	10
57901 00 012	10	3/8	7.5	30.5	42.5	20	17	10
57901 00 013	12	3/8	7.5	32.5	42.5	20	21.5	10
57901 00 014	12	1/2	9	35	47	24	21.5	10
57901 00 015	14	1/2	9	35.5	47	24	21.5	10

## 57910

## REGOLATORE UNIDIREZIONALE ORIENTABILE PER VALVOLA "UNIVERSAL SHORT"

ORIENTING FLOW REGULATOR FOR VALVE "UNIVERSAL SHORT"

DURCHFLOSSREGLER ZULUFTDROSSELUNG (DREHBAR) "UNIVERSAL SHORT"

RÉGLEUR DE DÉBIT À L'ADMISSION FILETAGE (ORIENTABLE) "UNIVERSAL SHORT"

REGULADOR UNIDIRECCIONAL ORIENTABLE PARA VÁLVULA "UNIVERSAL SHORT"

REGULADORA UNIDIRECCIONAL ORIENTÁVEL PARA VÁLVULA ROSCA "UNIVERSAL SHORT"

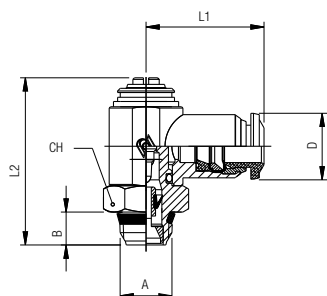
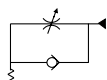

Code	Tube	A	B	L1	L2	CH	D	Pack.
57910 00 002	4	M5	4	19	29.5	8	10	10
57910 00 003	4	1/8	5.5	21	31	14	10	10
57910 00 004	5	M5	4	20	29.5	8	12.5	10
57910 00 005	5	1/8	5.5	21.5	31	14	12.5	10
57910 00 006	5	1/4	7	24.5	36.5	17	12.5	10
57910 00 007	6	M5	4	20.5	29.5	8	12.5	10
57910 00 008	6	1/8	5.5	22.5	31	14	12.5	10
57910 00 009	6	1/4	7	25	36.5	17	12.5	10
57910 00 010	8	1/8	5.5	24	31	14	14	10
57910 00 011	8	1/4	7	26	36.5	17	14	10
57910 00 016	8	3/8	7.5	28.5	42.5	20	14	10
57910 00 017	10	1/4	7	28.5	36.5	17	17	10
57910 00 012	10	3/8	7.5	30.5	42.5	20	17	10
57910 00 013	12	3/8	7.5	32.5	42.5	20	21.5	10
57910 00 014	12	1/2	9	35	47	24	21.5	10
57910 00 015	14	1/2	9	35.5	47	24	21.5	10

## 57920

## REGOLATORE BIDIREZIONALE ORIENTABILE "UNIVERSAL SHORT"

ORIENTING BI-DIRECTIONAL FLOW REGULATOR "UNIVERSAL SHORT"

DURCHFLOSSREGLER BI-DIREKTIONAL (DREHBAR) "UNIVERSAL SHORT"

RÉGLEUR DE DÉBIT BI-DIRECTIONNEL FILETAGE (ORIENTABLE) "UNIVERSAL SHORT"

REGULADOR BIDIRECCIONAL ORIENTABLE "UNIVERSAL SHORT"

REGULADORA BI-DIRECCIONAL ORIENTÁVEL ROSCA "UNIVERSAL SHORT"

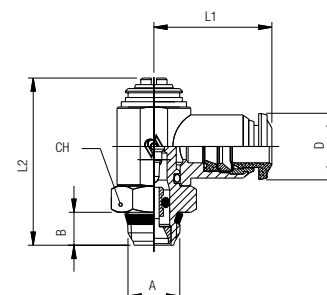

Code	Tube	A	B	L1	L2	CH	D	Pack.
57920 00 002	4	M5	4	19	29.5	8	10	10
57920 00 003	4	1/8	5.5	21	31	14	10	10
57920 00 004	5	M5	4	20	29.5	8	12.5	10
57920 00 005	5	1/8	5.5	21.5	31	14	12.5	10
57920 00 006	5	1/4	7	24.5	36.5	17	12.5	10
57920 00 007	6	M5	4	20.5	29.5	8	12.5	10
57920 00 008	6	1/8	5.5	22.5	31	14	12.5	10
57920 00 009	6	1/4	7	25	36.5	17	12.5	10
57920 00 010	8	1/8	5.5	24	31	14	14	10
57920 00 011	8	1/4	7	26	36.5	17	14	10
57920 00 016	8	3/8	7.5	28.5	42.5	20	14	10
57920 00 017	10	1/4	7	28.5	36.5	17	17	10
57920 00 012	10	3/8	7.5	30.5	42.5	20	17	10
57920 00 013	12	3/8	7.5	32.5	42.5	20	21.5	10
57920 00 014	12	1/2	9	35	47	24	21.5	10
57920 00 015	14	1/2	9	35.5	47	24	21.5	10

## 57905

## REGOLATORE UNIDIREZIONALE ORIENTABILE PER CILINDRO "UNIVERSAL SHORT"

ORIENTING FLOW REGULATOR FOR CYLINDER "UNIVERSAL SHORT"

DURCHFLOSSREGLER ABLUFTDROSSELUNG (DREHBAR) "UNIVERSAL SHORT"

RÉGLEUR DE DÉBIT À L'ÉCHAPPEMENT FILETAGE (ORIENTABLE) "UNIVERSAL SHORT"

REGULADOR UNIDIRECCIONAL ORIENTABLE PARA CILINDRO "UNIVERSAL SHORT"

REGULADORA UNIDIRECCIONAL ORIENTÁVEL PARA CILINDRO ROSCA "UNIVERSAL SHORT"

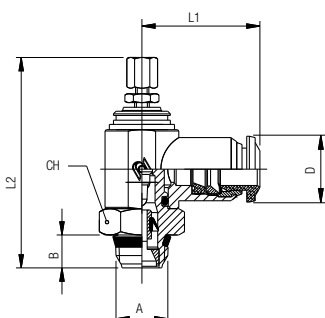
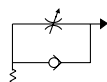

Code	Tube	A	B	L1	L2 min	L2 max	CH	D	Pack.
57905 00 002	4	M5	4	19	39.5	43.5	8	10	10
57905 00 003	4	1/8	5.5	21	44	49	14	10	10
57905 00 004	5	M5	4	20	39.5	43.5	8	12.5	10
57905 00 005	5	1/8	5.5	21.5	44	49	14	12.5	10
57905 00 006	5	1/4	7	24.5	48.5	55	17	12.5	10
57905 00 007	6	M5	4	20.5	39.5	43.5	8	12.5	10
57905 00 008	6	1/8	5.5	22.5	44	49	14	12.5	10
57905 00 009	6	1/4	7	25	48.5	55	17	12.5	10
57905 00 010	8	1/8	5.5	24	44	49	14	14	10
57905 00 011	8	1/4	7	26	48.5	55	17	14	10
57905 00 016	8	3/8	7.5	28.5	56	65	20	14	10
57905 00 017	10	1/4	7	28.5	48.5	55	17	17	10
57905 00 012	10	3/8	7.5	30.5	56	65	20	17	10
57905 00 013	12	3/8	7.5	32.5	56	65	20	21.5	10
57905 00 014	12	1/2	9	35	62	69	24	21.5	10
57905 00 015	14	1/2	9	35.5	62	69	24	21.5	10

## 57915

## REGOLATORE UNIDIREZIONALE ORIENTABILE PER VALVOLA "UNIVERSAL SHORT"

ORIENTING FLOW REGULATOR FOR VALVE "UNIVERSAL SHORT"

DURCHFLOSSREGLER ZULUFTDROSSELUNG (DREHBAR) "UNIVERSAL SHORT"

RÉGLEUR DE DÉBIT À L'ADMISSION FILETAGE (ORIENTABLE) "UNIVERSAL SHORT"

REGULADOR UNIDIRECCIONAL ORIENTABLE PARA VÁLVULA "UNIVERSAL SHORT"

REGULADORA UNIDIRECCIONAL ORIENTÁVEL PARA VÁLVULA ROSCA "UNIVERSAL SHORT"

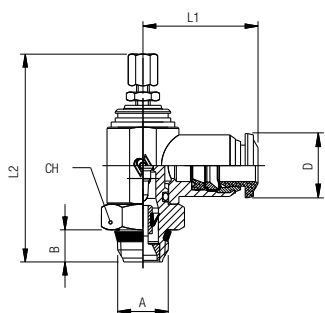
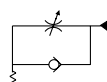

Code	Tube	A	B	L1	L2 min	L2 max	CH	D	Pack.
57915 00 002	4	M5	4	19	39.5	43.5	8	10	10
57915 00 003	4	1/8	5.5	21	44	49	14	10	10
57915 00 004	5	M5	4	20	39.5	43.5	8	12.5	10
57915 00 005	5	1/8	5.5	21.5	44	49	14	12.5	10
57915 00 006	5	1/4	7	24.5	48.5	55	17	12.5	10
57915 00 007	6	M5	4	20.5	39.5	43.5	8	12.5	10
57915 00 008	6	1/8	5.5	22.5	44	49	14	12.5	10
57915 00 009	6	1/4	7	25	48.5	55	17	12.5	10
57915 00 010	8	1/8	5.5	24	44	49	14	14	10
57915 00 011	8	1/4	7	26	48.5	55	17	14	10
57915 00 016	8	3/8	7.5	28.5	56	65	20	14	10
57915 00 017	10	1/4	7	28.5	48.5	55	17	17	10
57915 00 012	10	3/8	7.5	30.5	56	65	20	17	10
57915 00 013	12	3/8	7.5	32.5	56	65	20	21.5	10
57915 00 014	12	1/2	9	35	62	69	24	21.5	10
57915 00 015	14	1/2	9	35.5	62	69	24	21.5	10

## 57925

## REGOLATORE BIDIREZIONALE ORIENTABILE "UNIVERSAL SHORT"

ORIENTING BI-DIRECTIONAL FLOW REGULATOR "UNIVERSAL SHORT"

DURCHFLOSSREGLER ABLUFTDROSSELUNG (DREHBAR) "UNIVERSAL SHORT"

RÉGLEUR DE DÉBIT BI-DIRECTIONNEL FILETAGE (ORIENTABLE) "UNIVERSAL SHORT"

REGULADOR BIDIRECCIONAL ORIENTABLE "UNIVERSAL SHORT"

REGULADORA BI-DIRECCIONAL ORIENTÁVEL ROSCA "UNIVERSAL SHORT"

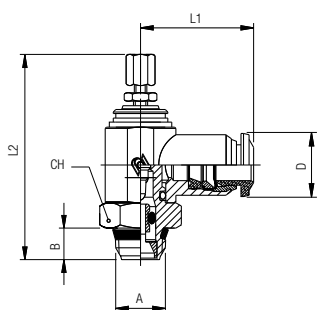

Code	Tube	A	B	L1	L2 min	L2 max	CH	D	Pack.
57925 00 002	4	M5	4	19	39.5	43.5	8	10	10
57925 00 003	4	1/8	5.5	21	44	49	14	10	10
57925 00 004	5	M5	4	20	39.5	43.5	8	12.5	10
57925 00 005	5	1/8	5.5	21.5	44	49	14	12.5	10
57925 00 006	5	1/4	7	24.5	48.5	55	17	12.5	10
57925 00 007	6	M5	4	20.5	39.5	43.5	8	12.5	10
57925 00 008	6	1/8	5.5	22.5	44	49	14	12.5	10
57925 00 009	6	1/4	7	25	48.5	55	17	12.5	10
57925 00 010	8	1/8	5.5	24	44	49	14	14	10
57925 00 011	8	1/4	7	26	48.5	55	17	14	10
57925 00 016	8	3/8	7.5	28.5	56	65	20	14	10
57925 00 017	10	1/4	7	28.5	48.5	55	17	17	10
57925 00 012	10	3/8	7.5	30.5	56	65	20	17	10
57925 00 013	12	3/8	7.5	32.5	56	65	20	21.5	10
57925 00 014	12	1/2	9	35	62	69	24	21.5	10
57925 00 015	14	1/2	9	35.5	62	69	24	21.5	10