



## 12.3 DOUBLE ROW SELF ALIGNING BALL BEARINGS

### Design

Bearings are designed with two rows of balls and round raceway on the outer ring, which enables certain tilting of the inner ring towards the outer ring around the bearing centre without impeding bearing function (fig. 12.3.1). Bearings are made with a cylindrical (a) or tapered (b) bore and are non-detachable. The self-aligning ability, while maintaining functionality, determines the bearing application in cases, where certain misalignment of bores in the bearing hubs or deflection and oscillation of the shaft are expected. Due to the small contact angle and imperfect adherence of the balls to the raceways, they are unsuitable for capturing greater axial forces.

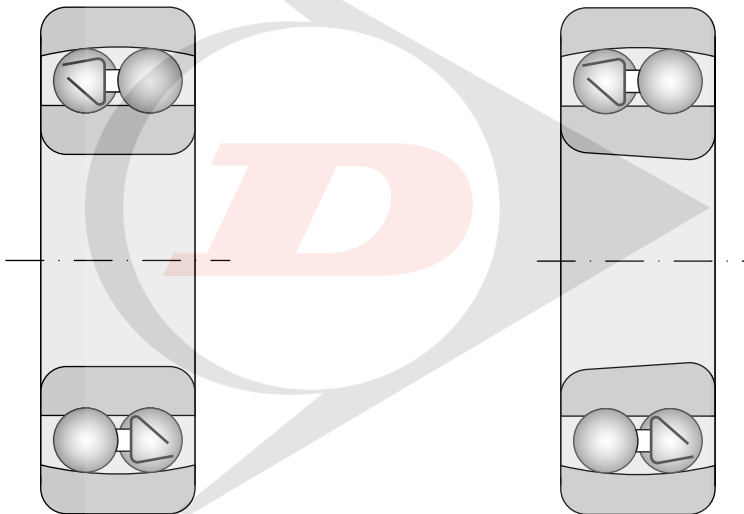

Fig. 12.3.1a

Fig. 12.3.1b

Due to the small adherence of balls on the outer ring spherical surface, self-aligning ball bearings elicit little friction in comparison to other types of bearings and the heat generated is thus also less. The Dunlop BTL product line includes only standard uncovered bearings.

#### Standard design

Dunlop BTL double row self-aligning ball bearings, manufactured to NEW FORCE standards, are designated as \*\* in the tables. Standard self-aligning ball bearings are designed with a cylindrical bore. They are also alternatively



designed with a tapered bore (with a 1:12 taper ratio).

Certain series 12 and 13 bearings contain overlapping balls even in the basic non-tilted ring position of the face of both rings. The size of the overlap is specified in the catalogue tables.

## Accessories

Adapter sleeves are a basic accessory to self aligning ball bearings. They serve to fasten bearings with a tapered bore onto the cylindrical shaft. Adapter sleeves are described in the chapter "Bearing accessories." The assignment of adapter sleeves is specified in the catalogue tables.

## Main dimensions

The main dimensions of bearings are consistent with standard ISO 15 and are listed for individual bearings in the tables of the publication.

## Precision

Bearings are currently produced at a normal degree of precision P0, which is not marked. Bearings for more demanding loadings and higher degree of precision P6 are also supplied.

The dimensional and operational precision tolerances are listed in tables 7.2 to 7.4b and are consistent with standard ISO 492.

## Self-alignment ability

Table 12.3.1

Bearing type	Permissible tilt $\alpha$
d<10mm; series 126; series 13; series 23	$\pm 3^\circ$
series 12; series 22	$\pm 2^\circ 30'$

Self aligning ball bearings enable, within certain limits, the mutual alignment of rings without negatively affecting the bearing function (fig. 4.9a)

Permissible alignment values of bearing rings, while maintaining functionality, are listed in table 12.3.1.

## Internal clearance

Commonly manufactured bearings have a normal internal radial clearance, which is not labelled. Bearings with a reduced clearance C2 or increased radial clearance C3 are supplied for special conditions. The supplier must be consulted for delivery of bearings with C4 and C5 clearance.

Clearance values that conform to standard ISO 5753 are listed in table 7.18. Values apply to bearings prior to installation and without the use of a measuring load.



Table 12.3.2

Bearings with steel sheet or brass cage	Bearings with massive brass or steel cage
d < 10mm; series 126	-
1200 to 1222	1224 až 1230
2200 to 2222	-
1300 to 1322	1324
2304 to 2320 <sup>1)</sup>	2322

<sup>1)</sup> Bearing 2305 is manufactured with a massive plastic cage with filler (TNGN)

## Cages

Bearings, in their standard design, general have cages as listed in table 12.3.2 (the symbol characterizing the material and cage design is usually not specified).

Note:

TNGN cages can work in bearings for normal operating conditions, i.e. up to +120 °C.

## Axial loading capacity

The ability of self aligning ball bearings, installed on adapter sleeves on a shaft without shoulder, to carry axial loads depends on the friction between the sleeve and the shaft. The permissible axial loading capacity can be roughly determined by the relationship

$$F_{ap} = 0.003 \cdot B \cdot d$$

$F_{ap}$  . . . . . maximum permissible axial loading capacity [kN]

$B$  . . . . . bearing width [mm]

$d$  . . . . . bearing bore diameter [mm]

## Minimal load

A certain minimal load must act on all single-point contact or line contact bearings to ensure their satisfactory operation. This also applies for self aligning ball bearings, especially when they must operate at high speeds, with high acceleration, or when the direction of the acting load suddenly changes. Under such conditions, the inertial forces of balls, cages, and friction in the lubricant can have a negative effect on the rolling conditions and can cause harmful slippage between the balls and the raceways.

The requisite minimal load for self aligning ball bearings can be estimated using the relationship

$$P_m = 0.01 \cdot C_o$$



$P_m$  . . . . . minimal equivalent load [kN]

$C_0$  . . . . . static load capacity [kN]

A higher minimum load may be required when starting under low temperatures or when using a high visco-sity lubricant. The weight of components associated with the bearing together with external forces is often greater than the requisite minimal load. If not, then an auxiliary axial load may act on the bearing, which is elicited e.g. by increased tension of a belt, etc.

### Equivalent dynamic radial load of bearing

$$P_r = F_r + Y_1 F_a \quad \text{for } F_a/F_r \leq e \quad [\text{kN}]$$

$$P_r = 0.65 F_r + Y_2 F_a \quad \text{for } F_a/F_r > e \quad [\text{kN}]$$

The values of coefficients  $e$ ,  $Y_1$  and  $Y_2$  for individual bearings are listed in the tables of the publication.

### Equivalent static radial load of bearing

$$P_{or} = F_r + Y_0 F_a \quad [\text{kN}]$$

The values of coefficients  $Y_0$  for individual bearings are listed in the tables of the publication.

### Additional markings

Markings of standard bearings and of bearings with a tapered bore are listed in the tables of the publication. Divergence from the standard design is marked by the additional characters provided below:

C2 . . . . . Radial internal clearance less than Normal

C3 . . . . . Radial internal clearance greater than Normal

K . . . . . Tapered bore with 1:12 taper ratio

TNGN. . . . . Injected open cage from fibreglass reinforced polyamide 6.6, ball-guided

### Installation of bearings with tapered bore



Bearings with a tapered bore have a taper size of 1:12. Bearings with a tapered bore are fastened on a cylindrical shaft using adapter sleeves. Sleeve designations belonging to individual bearings are listed in the tables of the publication.

Self aligning ball bearings with tapered bore are always installed with an overlap on the conical journal or on the adapter or withdrawal sleeve. A decrease in the internal radial bearing clearance or in the axial shift of the internal ring on the conical journal can be used to measure the overlap size. Suitable methods for checking correct installation of self aligning ball bearings with a tapered bore are provided below:

- Measuring the decrease of clearance.
- Measuring the lock nut tightening angle.
- Measuring the axial displacement.

### Measuring the decrease of clearance

When installing self aligning ball bearings in standard design with a relatively small Normal radial internal clearance, it generally suffices to check the decrease in clearance during installation by turning and tilting the outer bearing ring. If the bearing is properly installed, then the outer ring can easily be turned; however, you must feel slight resistance when tilting the bearing outer ring. In such a case, the bearing is installed with a correct overlap.

In certain cases, however, the resulting internal clearance for the give application may be too small. Consequently, a bearing with an internal radial clearance of C3 should be used.

### Measuring the torque of lock nuts

Measuring the tightening angle of the lock nut presents an easy method of installing self aligning ball bearings with a tapered bore. Recommended tightening angles and lock nut torques are specified in table 12.3.3.

The bearing must be pushed onto the conical journal or sleeve prior to final nut tightening so that it touches the contact surfaces along its entire perimeter (i.e. so it cannot be turned). By tightening the nut by the given angle  $\alpha$ , move the bearing on the tapered surface the correct distance. The resulting clearance in the bearing must be checked by turning and tilting the outer bearing ring.

Then unscrew the nut and carefully install the lock washer and re-tighten the nut. Secure the nut by bending the lock washer tab so the tab fits into the slot on the lock nut.

### Measuring axial displacement

Installation of bearings with a tapered bore can also be based on measuring the axial displacement of the inner ring on the tapered contact surface. The recommended values of requisite axial displacement "s" are listed in the following table.



Table 12.3.3

Bore diameter	Tightening angle	Axial displacement
d	$\alpha$	s
mm	degrees	mm
20	80	0,22
25	55	0,22
30	55	0,22
35	70	0,3
40	70	0,3
45	80	0,35
50	80	0,35
55	75	0,4
60	75	0,4
65	80	0,4
70	80	0,4
75	85	0,45
80	85	0,45
85	110	0,6
90	110	0,6
95	110	0,6
100	110	0,6
110	125	0,7
120	125	0,7

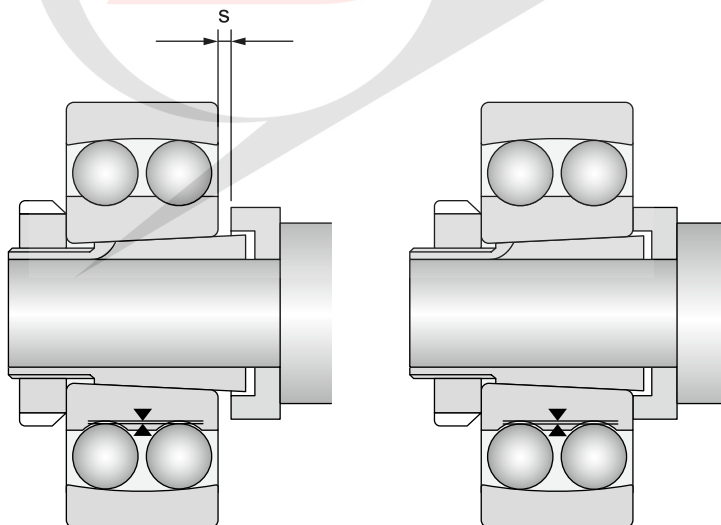
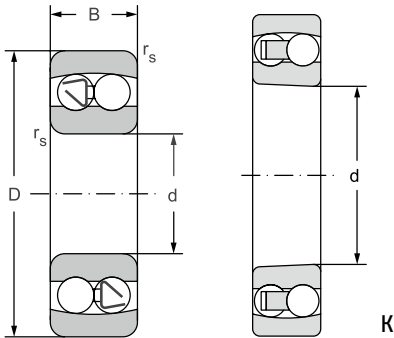

Fig. 12.3.2



Double row self aligning ball bearings d = 10 to 150 mm

d = 10 to 50 mm



12.3.1

Main dimensions					Basic load rating		Fatigue load limit	Limiting speed for lubrication with		Bearing designation	
d	D	B	B <sub>i</sub> <sup>1)</sup>	r <sub>s</sub>	dynamic	static	P <sub>u</sub>	Grease	Oil	with cylindrical bore	with tapered bore
mm					C <sub>r</sub>	C <sub>or</sub>					
					kN		kN				
10	30	14	-	0,6	7,28	1,58	0,07	25 000	30 000	<b>2200</b>	-
12	32	10	-	0,6	5,59	1,26	0,06	24 000	28 000	<b>1201</b>	-
15	35	11	-	0,6	7,41	1,74	0,08	21 000	25 000	<b>1202</b>	-
	35	14	-	0,6	7,61	1,81	0,08	21 000	25 000	<b>2202</b>	-
17	40	12	-	0,6	8,14	2,03	0,09	17 000	20 000	<b>1203**</b>	<b>1203K**</b>
20	47	14	-	1,0	10,20	2,66	0,12	14 000	17 000	<b>1204**</b>	<b>1204K**</b>
25	52	15	-	1,0	12,50	3,35	0,15	12 600	15 000	<b>1205**</b>	<b>1205K**</b>
	52	18	-	1,0	12,90	3,48	0,16	12 600	15 000	<b>2205**</b>	<b>2205K**</b>
	62	17	-	1,1	18,50	5,01	0,23	10 000	13 000	<b>1305**</b>	<b>1305K**</b>
	62	24	-	1,1	25,20	6,56	0,30	10 000	12 000	<b>2305TNGN**</b>	<b>2305KTNGN**</b>
30	62	16	-	1,0	16,70	4,73	0,22	11 000	13 000	<b>1206**</b>	<b>1206K**</b>
	62	20	-	1,0	15,80	4,55	0,21	11 000	13 000	<b>2206**</b>	<b>2206K**</b>
	72	19	-	1,1	22,00	6,31	0,29	9 400	11 000	<b>1306**</b>	<b>1306K**</b>
	72	27	-	1,1	32,30	8,74	0,40	8 400	10 000	<b>2306**</b>	<b>2306K**</b>
35	72	17	-	1,1	16,30	5,11	0,23	9 400	11 000	<b>1207**</b>	<b>1207K**</b>
	72	23	-	1,1	22,40	6,68	0,30	9 400	11 000	<b>2207**</b>	<b>2207K**</b>
	80	31	-	1,5	39,50	11,20	0,51	7 200	8 800	<b>2307</b>	<b>2307K</b>
40	80	18	-	1,1	19,90	6,56	0,30	7 900	9 400	<b>1208**</b>	<b>1208K**</b>
	90	23	-	1,5	29,90	9,81	0,45	7 100	8 400	<b>1308**</b>	<b>1308K**</b>
	90	33	-	1,5	46,10	13,30	0,60	6 700	7 900	<b>2308**</b>	<b>2308K**</b>
45	85	19	-	1,1	22,60	7,36	0,33	7 500	8 900	<b>1209**</b>	<b>1209K**</b>
	85	23	-	1,1	24,00	8,10	0,37	7 500	8 900	<b>2209**</b>	<b>2209K**</b>
	100	25	-	1,5	39,10	12,80	0,58	6 300	7 500	<b>1309**</b>	<b>1309K**</b>
	100	36	-	1,5	55,40	16,50	0,75	6 000	7 100	<b>2309**</b>	<b>2309K**</b>
50	90	20	-	1,1	23,40	8,10	0,37	7 100	8 400	<b>1210**</b>	<b>1210K**</b>
	90	23	-	1,1	24,00	8,41	0,38	7 100	8 400	<b>2210**</b>	<b>2210K**</b>
	110	27	-	2,0	44,60	14,10	0,64	5 600	6 700	<b>1310**</b>	<b>1310K**</b>
	110	40	-	2,0	64,50	19,80	0,90	5 300	6 300	<b>2310</b>	<b>2310K</b>

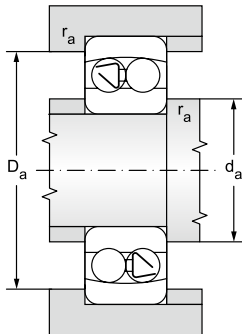

\*\* Bearings in the new standard NEW FORCE  
1) The dimension B1 indicates the bearing width measured over balls if they protrude from the bearing side faces

Abutment and Fillet Dimensions				Weight		Respective adapter sleeve	Coefficients			
d	d <sub>a</sub> min	D <sub>a</sub> max	r <sub>a</sub> max	-	K		e	Y <sub>1</sub>	Y <sub>2</sub>	Y <sub>0</sub>
mm				kg						
10	14	26	0,6	0,0	-	-	0,65	1,0	1,5	1
12	16	18	0,6	0,0	-	-	0,34	1,9	2,9	2,0
15	19	31	0,6	0,0	-	-	0,33	1,9	2,9	2,0
	19	31	0,6	0,1	-	-	0,49	1,3	2,0	1,3
17	21	36	0,6	0,1	0,1	H203	0,31	2,1	3,2	2,2
20	25	42	1,0	0,1	0,1	H204	0,27	2,3	3,6	2,4
25	30	47	1,0	0,1	0,1	H205	0,27	2,3	3,6	2,4
	30	47	1,0	0,2	0,2	H305	0,43	1,5	2,3	1,5
	32	55	1,0	0,3	0,3	H305	0,28	2,3	3,5	2,4
	31	55	1,0	0,3	0,3	H2305	0,47	1,3	2,1	1,4
30	35	57	1,0	0,2	0,2	H206	0,25	2,6	4,0	2,7
	35	57	1,0	0,3	0,3	H306	0,40	1,6	2,5	1,7
	36	65	1,0	0,4	0,4	H306	0,26	2,5	3,8	2,6
	36	65	1,0	0,5	0,5	H2306	0,44	1,4	2,2	1,5
35	42	65	1,0	0,3	0,3	H207	0,23	2,7	4,2	2,9
	42	65	1,0	0,4	0,4	H307	0,37	1,7	2,6	1,8
	44	71	1,5	0,7	0,7	H2307	0,46	1,4	2,1	1,4
40	47	73	1,0	0,4	0,4	H208	0,22	2,9	4,4	3,0
	47	81	1,5	0,7	0,7	H308	0,24	2,6	4,1	2,7
	47	81	1,5	0,9	0,9	H2308	0,43	1,5	2,3	1,5
45	52	78	1,0	0,5	0,5	H209	0,21	3,0	4,6	3,1
	52	78	1,0	0,6	0,5	H309	0,31	2,1	3,2	2,2
	52	91	1,5	1,0	0,9	H309	0,25	2,5	3,9	2,7
	52	91	1,5	1,2	1,2	H2309	0,42	1,5	2,3	1,6
50	57	83	1,0	0,5	0,5	H210	0,20	3,1	4,9	3,3
	57	83	1,0	0,6	0,6	H310	0,29	2,2	3,4	2,3
	60	100	2,0	1,2	1,2	H310	0,24	2,7	4,1	2,8
	61	99	2,0	1,7	1,7	H2310	0,43	1,5	2,3	1,6





Double row self aligning ball bearings

d = 55 to 100 mm

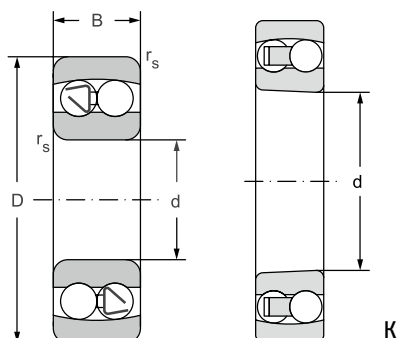

12.3.1

Main dimensions					Basic load rating		Fatigue load limit	Limiting speed for lubrication with		Bearing designation	
d	D	B	B <sub>1</sub> <sup>1)</sup>	r <sub>s</sub>	dynamic	static		Grease	Oil	with cylindrical bore	with tapered bore
mm					C <sub>r</sub>	C <sub>or</sub>	P <sub>u</sub>				
55	100	21	-	1,5	27,60	10,00	0,45	6 300	7 500	<b>1211**</b>	<b>1211K**</b>
	100	25	-	1,5	27,30	10,00	0,45	6 300	7 500	<b>2211**</b>	<b>2211K**</b>
	120	29	-	2,0	51,50	18,20	0,82	5 300	6 300	<b>1311</b>	<b>1311K</b>
60	110	22	-	1,5	31,00	11,70	0,53	5 600	6 700	<b>1212**</b>	<b>1212K**</b>
	110	28	-	1,5	35,20	12,60	0,57	5 600	6 700	<b>2212**</b>	<b>2212K**</b>
	130	31	-	2,0	58,80	20,70	0,94	4 700	5 600	<b>1312**</b>	<b>1312K**</b>
65	120	23	-	1,5	31,90	12,30	0,56	5 300	6 300	<b>1213**</b>	<b>1213K**</b>
	120	31	-	1,5	44,90	16,50	0,75	5 300	6 300	<b>2213**</b>	<b>2213K**</b>
	140	48	-	2,1	98,90	32,40	1,47	4 000	4 800	<b>2313**</b>	<b>2313K**</b>
70	125	31	-	1,5	45,20	17,10	0,78	5 000	6 000	<b>1214**</b>	<b>1214K**</b>
	150	35	-	2,0	74,50	27,50	1,20	4 200	5 000	<b>1314M</b>	<b>1314KM</b>
	150	51	-	2,1	112,00	37,60	1,63	3 800	4 500	<b>2314**</b>	<b>2314K**</b>
75	130	25	-	1,5	40,10	15,50	0,70	4 700	5 600	<b>1215**</b>	<b>1215K**</b>
	130	31	-	1,5	45,50	17,80	0,80	4 700	5 600	<b>2215**</b>	<b>2215K**</b>
	160	37	-	2,1	81,70	29,90	1,25	3 800	4 500	<b>1315**</b>	<b>1315K**</b>
	160	55	-	2,1	127,00	43,00	1,80	3 500	4 200	<b>2315**</b>	<b>2315K**</b>
80	140	26	-	2,0	41,00	16,80	0,73	4 500	5 300	<b>1216**</b>	<b>1216K**</b>
	140	33	-	2,0	50,50	20,00	0,87	4 500	5 300	<b>2216**</b>	<b>2216K**</b>
85	150	28	-	2,0	50,60	20,30	0,85	4 000	4 700	<b>1217**</b>	<b>1217K**</b>
	180	41	-	3,0	101,00	37,60	1,48	3 300	4 000	<b>1317**</b>	<b>1317K**</b>
	180	60	-	3,0	144,00	51,10	2,02	3 200	3 800	<b>2317**</b>	<b>2317K**</b>
90	160	30	-	2,0	58,60	23,30	0,95	3 800	4 500	<b>1218**</b>	<b>1218K**</b>
	160	40	-	2,0	72,40	28,70	1,17	3 800	4 500	<b>2218**</b>	<b>2218K**</b>
	190	64	-	3,0	158,00	57,30	2,20	3 000	3 500	<b>2318**</b>	<b>2318K**</b>
95	170	32	-	2,1	65,60	27,10	1,07	3 500	4 200	<b>1219**</b>	<b>1219K**</b>
	170	43	-	2,1	85,70	34,10	1,35	3 500	4 200	<b>2219**</b>	<b>2219K**</b>
	200	45	48	3,0	136,00	51,10	1,91	3 000	3 500	<b>1319**</b>	<b>1319K**</b>
	200	67	-	3,0	170,00	64,30	2,41	2 800	3 300	<b>2319**</b>	<b>2319K**</b>

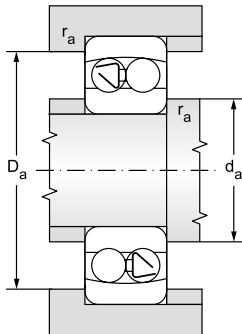

\*\* Bearings in the new standard NEW FORCE

<sup>1)</sup> The dimension B<sub>1</sub> indicates the bearing width measured over balls if they protrude from the bearing side faces

Abutment and Fillet Dimensions				Weight		Respective adapter sleeve	Coefficients			
d	d <sub>a</sub> min	D <sub>a</sub> max	r <sub>a</sub> max	-	K		e	Y <sub>1</sub>	Y <sub>2</sub>	Y <sub>0</sub>
mm				kg						
55	62	91	1,5	0,7	0,7	H211	0,20	3,2	5,0	3,4
	62	91	1,5	0,8	0,8	H311	0,28	2,3	3,5	2,4
	66	109	2,0	1,0	1,0	H311	0,23	2,7	4,3	2,9
60	67	101	1,5	0,9	0,9	H212	0,19	3,4	5,3	3,6
	67	101	1,5	1,1	1,1	H312	0,28	2,3	3,5	2,4
	72	118	2,0	2,0	1,9	H312	0,23	2,8	4,3	2,9
65	72	111	1,5	1,2	1,1	H213	0,17	3,7	5,7	3,9
	72	111	1,5	1,5	1,4	H313	0,28	2,2	3,5	2,3
	76	128	2,0	3,3	3,2	H2313	0,38	1,6	2,5	1,7
70	77	116	1,5	1,5	1,5	H314	0,27	2,4	3,7	2,5
	82	138	2,0	3,0	3,0	H314	0,22	2,8	4,4	3,0
	82	138	2,0	3,9	3,8	H2314	0,38	1,7	2,6	1,8
75	82	121	1,5	1,4	1,3	H215	0,18	3,6	5,6	3,8
	82	121	1,5	1,6	1,6	H315	0,25	2,5	3,9	2,6
	86	148	2,0	3,6	3,5	H315	0,22	2,8	4,4	3,0
	86	148	2,0	4,7	4,6	H2315	0,38	1,7	2,6	1,7
80	90	130	2,0	1,7	1,6	H216	0,16	3,9	6,1	4,1
	90	130	2,0	2,0	2,0	H316	0,25	2,5	3,9	2,6
85	95	140	2,0	2,1	2,0	H217	0,17	3,7	5,7	3,9
	98	166	2,5	5,0	4,9	H317	0,22	2,9	4,5	3,0
	98	166	2,5	6,7	6,6	H2317	0,37	1,7	2,7	1,8
90	100	150	2,0	2,5	2,5	H218	0,17	3,8	5,8	3,9
	100	150	2,0	3,2	3,1	H318	0,27	2,4	3,6	2,5
	103	176	2,5	8,0	7,8	H2318	0,38	1,7	2,6	1,8
95	107	158	2,0	3,1	3,1	H219	0,17	3,6	5,7	3,9
	107	158	2,0	4,0	3,9	H319	0,27	2,4	3,6	2,5
	109	186	2,5	6,7	6,6	H319	0,23	2,7	4,3	2,9
	109	186	2,5	9,2	9,0	H2319	0,38	1,7	2,6	1,8



Double row self aligning ball bearings

d = 110 to 150 mm

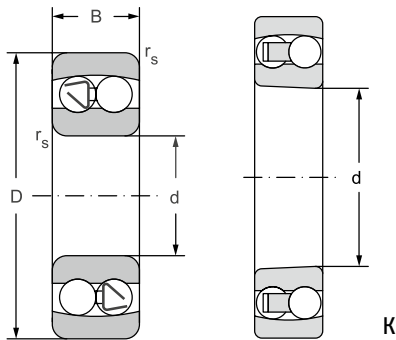

12.3.1

Main dimensions					Basic load rating		Fatigue load limit	Limiting speed for lubrication with		Bearing designation	
d	D	B	B <sub>1</sub> <sup>1)</sup>	r <sub>s</sub>	dynamic	static		Grease	Oil	with cylindrical bore	with tapered bore
mm					kN		kN	min <sup>-1</sup>			
100	180	34	-	2,1	71,10	29,30	1,13	3 300	4 000	<b>1220**</b>	<b>1220K**</b>
	180	46	-	2,1	96,90	40,60	1,56	3 300	4 000	<b>2220**</b>	<b>2220K**</b>
	215	47	52	3,0	147,00	58,40	2,12	2 800	3 300	<b>1320**</b>	<b>1320K**</b>
	215	73	-	3,0	198,00	77,90	2,82	2 700	3 200	<b>2320**</b>	<b>2320K**</b>
110	200	38	-	2,1	90,50	38,30	1,40	3 000	3 500	<b>1222**</b>	<b>1222K**</b>
	200	53	-	2,1	124,00	52,10	1,90	3 000	3 500	<b>2222**</b>	<b>2222K**</b>
	240	50	55	3,0	168,00	70,80	2,43	2 700	3 200	<b>1322**</b>	<b>1322K**</b>
	240	80	-	3,0	224,00	94,40	3,24	2 500	3 000	<b>2322**</b>	<b>2322K**</b>
120	215	42	45	2,1	119,00	52,10	1,83	2 800	3 300	<b>1224</b>	-
	260	55	62	3,0	196,00	90,90	3,00	2 500	3 000	<b>1324</b>	-
130	230	46	48	3,0	130,00	59,60	2,02	2 700	3 200	<b>1226**</b>	<b>1226K**</b>
140	250	50	54	3,0	164,00	72,20	2,35	2 500	3 000	<b>1228**</b>	<b>1228K**</b>
150	270	54	56	3,0	176,00	85,80	2,69	2 400	2 800	<b>1230**</b>	<b>1230K**</b>

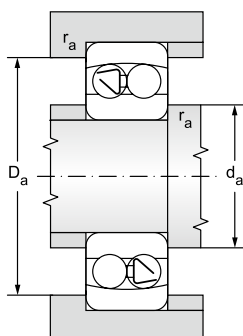

\*\* Bearings in the new standard NEW FORCE

<sup>1)</sup> The dimension B<sub>1</sub> indicates the bearing width measured over balls if they protrude from the bearing side faces

Abutment and Fillet Dimensions				Weight		Respective adapter sleeve	Coefficients			
d	d <sub>a</sub> min	D <sub>a</sub> max	r <sub>a</sub> max	-	K		e	Y <sub>1</sub>	Y <sub>2</sub>	Y <sub>0</sub>
mm				kg						
100	112	168	2,0	3,7	3,6	H220	0,17	3,6	5,6	3,8
	112	168	2,0	4,7	4,6	H320	0,27	2,4	3,6	2,5
	113	201	2,5	8,3	8,2	H320	0,24	2,7	4,1	2,8
	113	201	2,5	11,7	11,4	H2320	0,38	1,7	2,6	1,7
110	122	188	2,0	5,2	5,1	H222	0,17	3,6	5,6	3,8
	122	188	2,0	6,8	6,7	H322	0,28	2,3	3,5	2,4
	124	226	2,5	11,8	11,7	H322	0,22	2,8	4,4	3,0
	124	226	2,5	17,3	16,9	H2322	0,37	1,7	2,7	1,8
120	132	203	2,0	6,8	-	-	0,19	3,3	5,1	3,4
	134	246	2,5	15,5	-	-	0,24	2,7	4,1	2,8
130	144	216	2,5	8,3	8,1	-	0,2	3,3	5,0	3,4
140	154	236	2,5	10,9	10,6	-	0,20	3,1	4,8	3,3
150	164	256	2,5	13,8	13,5	-	0,2	3,2	5,0	3,4