



FYH®

SPHERICAL ROLLER UNITS



CATALOG NO.12000a



Introducing FYH Spherical Roller Bearing Units

More than sixty years of experience and innovation in the field of mounted ball bearing units has lead to the development of mounted spherical roller units that cater to a wide range of applications and industries. Bearing and housing production are accomplished entirely by FYH while utilizing only the highest quality materials available. Through meticulous design enhancements and careful material selection this heavy duty mounted roller series attains the designation of "**EXTRA TOUGH**".



Type E housing design

Units are designed to interchange with Type E housing dimensions as well as most spherical roller unit footprints. Elongated bolt holes are dimensioned to allow for a shortened or extended mounting pitch to accommodate practically any competitive tapered roller or spherical roller design.

Lubrication

FYH Roller Grease is a calcium sulfonate complex thickened lubricating grease formulated in 100% synthetic hydrocarbon base oil.

FYH Roller Grease has excellent low temperature and high temperature performance, and it provides excellent extreme pressure and anti-wear protection. FYH Roller Grease also provides excellent corrosion protection and water wash-out resistance.

Grease temperature range: -40 to 340°F (-40 to 170°C)

Available in fixed or expansion
(expansion shown)

Triple Lip Seal

±2° Self Aligning capability

The triple-lip seal maintains positive contact with a special sealing ring at virtually any angle of shaft mis-alignment. Our new patent pending sealing design protects the bearing against a variety of wet and dry contaminants and dramatically improves bearing life. The ability to accommodate shaft expansion is also available.

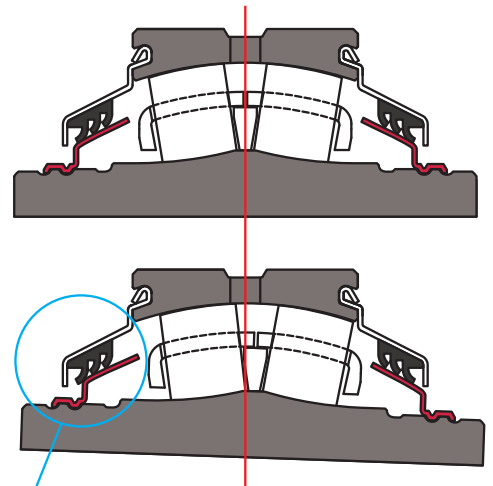

Positive seal contact is maintained during mis-alignment at any angle.

Semi Solid Base

One piece ductile iron housings

Ductile iron housings offer substantially better fracture resistance than cast iron, and the semi-solid base design provides an excellent mounting foundation and superior rigidity over competitive offerings.

The standard housing material from FYH is ductile iron, and additional material options may also be available.



Convertible from non-expansion to expansion

By simply moving a snap ring on the back of the unit the bearing can easily be converted from non-expansion to expansion or vice versa.

This procedure can be easily performed in the field even after the unit has been mounted.



TwoBolt Base Type E Pillow Block Units

XSE2P

d 40 ~ 100 mm

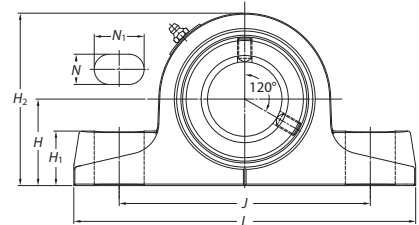
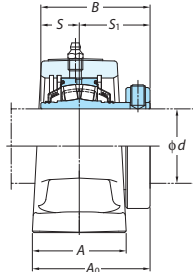
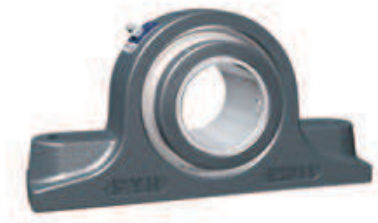

Unit No.	Bearing No.	Shaft Dia. inch mm d	Dimensions inch mm											Bolt Size inch mm			
			H	L	A	J	N	N ₁	H ₁	H ₂	A ₀	B	S		S ₁		
XSE2P408-22	XS408-22	1 3/8															
XSE2P408-23	XS408-23	1 7/16	1 7/8	7 3/8	2 5/32	5 9/32	19/32	1 3/32	1 1/4	3 3/4	2 5/8	2.531	1	1.531			
XSE2P408-24	XS408-24	1 1/2	47.6	187	55	134	15	28	32	95.6	66.4	64.3	25.4	38.9			
XSE2P408	XS408	40															
XSE2P409-27	XS409-27	1 11/16															
XSE2P409-28	XS409-28	1 3/4	2 1/8	7 7/8	2 3/8	5 25/32	19/32	1 3/32	1 5/16	4 1/4	2 27/32	2.657	1	1.657			
XSE2P409	XS409	45	54	200	60	147	15	28	33	108	72.1	67.5	25.4	42.1			
XSE2P410-31	XS410-31	1 15/16															
XSE2P410	XS410	50	2 1/4	8 29/32	2 7/16	6 17/32	25/32	1 5/16	1 3/8	4 1/2	3 1/16	2.843	1	1.843			
XSE2P410-32	XS410-32	2	57.2	226	62	166	20	33	35	114	77.8	72.2	25.4	46.8			
XSE2P411	XS411	55															
XSE2P411-35	XS411-35	2 3/16	2 1/2	9 21/32	2 5/8	7 1/8	25/32	1 13/32	1 5/8	4 31/32	3 1/8	2.937	1.126	1.811			
XSE2P411-35	XS411-35	2 3/16	63.5	245	67	181	20	36	41	126	79.5	74.6	28.6	46			
XSE2P413-39	XS413-39	2 7/16															
XSE2P413-40	XS413-40	2 1/2	2 3/4	10 1/4	2 7/8	7 11/16	25/32	1 9/16	1 25/32	5 19/32	3 3/8	3.205	1.252	1.953			
XSE2P413	XS413	65	69.8	260	73	195	20	40	45	142	86.1	81.4	31.8	49.6			
XSE2P415-43	XS415-43	2 11/16															
XSE2P415-44	XS415-44	2 3/4															
XSE2P415-47	XS415-47	2 15/16	3 1/8	11 5/8	3	8 11/16	15/16	1 11/16	1 25/32	6 1/4	3 13/16	3.594	1.252	2.343			
XSE2P415	XS415	75	79.5	295	76	221	24	43	44.9	158.8	97	91.3	31.8	59.5			
XSE2P415-48	XS415-48	3															
XSE2P418-55	XS418-55	3 7/16															
XSE2P418-56	XS418-56	3 1/2	3 3/4	13 1/2	3 3/8	10 5/16	1 1/16	1 23/32	2 1/4	7 15/32	4 1/4	4.079	1.516	2.563			
XSE2P418	XS418	90	95.2	343	86	262	27	44	57	189.5	108.1	103.6	38.5	65.1			
XSE2P420	XS420	100															
XSE2P420-63	XS420-63	3 15/16	4 1/8	15 1/4	3 3/4	11 1/4	1 5/32	2 5/16	2 13/32	8 7/32	4 23/32	4.484	1.626	2.858			
XSE2P420-64	XS420-64	4	104.9	387	95	286	29	59	60.9	208.9	120.1	113.9	41.3	72.6			



FourBolt Flange Units



XS4F

d 40 ~ 100 mm

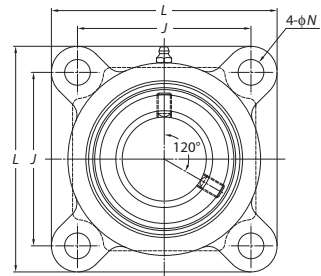
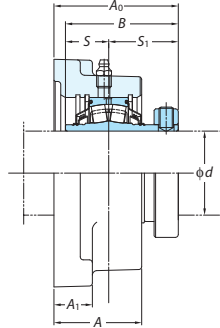

Unit No.	Bearing No.	Shaft Dia. inch mm d	Dimensions									Bolt Size inch mm			
			L	A	J	N	A ₁	A ₀	B	S	S ₁				
XS4F408-22	XS408-22	1 3/8													
XS4F408-23	XS408-23	1 7/16	4 3/4	2 3/32	3 17/32	35/64	3/4	2 3/4	2.531	1	1.531			1/2	
XS4F408-24	XS408-24	1 1/2	120.7	52.8	89.7	14	19	70.2	64.3	25.4	38.9			M12	
XS4F408	XS408	40													
XS4F409-27	XS409-27	1 11/16													
XS4F409-28	XS409-28	1 3/4	5 1/8	2 5/32	3 57/64	35/64	3/4	2 31/32	2.657	1	1.657			1/2	
XS4F409	XS409	45	130.2	54.8	98.8	14	19	75.4	67.5	25.4	42.1			M12	
XS4F410-31	XS410-31	1 15/16													
XS4F410	XS410	50	5 5/16	2 5/32	4 1/16	35/64	3/4	3 5/32	2.843	1	1.843			1/2	
XS4F410-32	XS410-32	2	135	55	103.2	14	19	80.2	72.2	25.4	46.8			M12	
XS4F411	XS411	55	5 7/8	2 9/32	4 33/64	21/32	1	3 1/4	2.937	1.126	1.811			5/8	
XS4F411-35	XS411-35	2 3/16	149.2	58	114.7	17	25.4	82.2	74.6	28.6	46			M16	
XS4F413-39	XS413-39	2 7/16													
XS4F413-40	XS413-40	2 1/2	6 1/8	2 9/16	4 25/32	21/32	1	3 17/32	3.205	1.252	1.953			5/8	
XS4F413	XS413	65	156	65	121.4	17	25.4	89.3	81.4	31.8	49.6			M16	
XS4F415-43	XS415-43	2 11/16													
XS4F415-44	XS415-44	2 3/4	7 3/16	2 5/8	5 9/16	7/8	1	3 29/32	3.594	1.252	2.343			3/4	
XS4F415-47	XS415-47	2 15/16													
XS4F415	XS415	75	182.6	67	141.3	22	25.4	99.2	91.3	31.8	59.5			M20	
XS4F415-48	XS415-48	3													
XS4F418-55	XS418-55	3 7/16													
XS4F418-56	XS418-56	3 1/2	8 1/4	3 5/32	6 23/32	7/8	1 1/8	4 3/8	4.079	1.516	2.563			3/4	
XS4F418	XS418	90	209.6	80	170.7	22	28.6	111.5	103.6	38.5	65.1			M20	
XS4F420	XS420	100													
XS4F420-63	XS420-63	3 15/16	9 1/4	3 9/16	7 39/64	63/64	1 3/16	4 27/32	4.484	1.626	2.858			7/8	
XS4F420-64	XS420-64	4	235	90.5	193.3	25	30.2	123	113.9	41.3	72.6			M22	





Flange Cartridge Units

XS4FC

d 40 ~ 100 mm

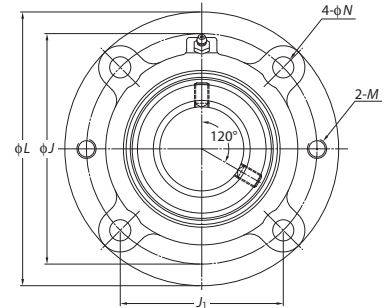
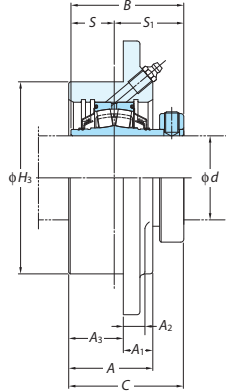

Unit No.	Bearing No.	Shaft Dia. inch mm d	Dimensions inch mm													Bolt Size inch mm				
			L	H ₃	J	J ₁	N	A	A ₁	A ₂	A ₃	C	M	B	S		S ₁			
XS4FC408-22	XS408-22	1 3/8																		
XS4FC408-23	XS408-23	1 7/16	5 1/4	3.625	4 3/8	3 3/32	7/16	1 27/32	5/8	1/2	1 7/32	2 17/32		2.531	1	1.531			3/8	
XS4FC408-24	XS408-24	1 1/2	133.4	92.075	111.1	78.6	11	46.8	15.8	12.7	31	64.3	3/8-16UNC	64.3	25.4	38.9			M10	
XS4FC408	XS408	40																		
XS4FC409-27	XS409-27	1 11/16																		
XS4FC409-28	XS409-28	1 3/4	6 5/32	4.25	5 1/8	3 5/8	33/64	1 29/32	5/8	1/2	1 17/64	2 23/32		2.657	1	1.657			1/2	
XS4FC409	XS409	45	156	107.95	130.2	92.1	13	48.4	16.2	12.7	32.2	69.1	7/16-14UNC	67.5	25.4	42.1			M12	
XS4FC410-31	XS410-31	1 15/16																		
XS4FC410	XS410	50	6 3/8	4.5	5 3/8	3 51/64	33/64	2	23/32	9/16	1 17/64	2 55/64		2.843	1	1.843			1/2	
XS4FC410-32	XS410-32	2	162	114.3	136.5	96.5	13	50.8	18.6	14.3	32.2	72.6	7/16-14UNC	72.2	25.4	46.8			M12	
XS4FC411	XS411	55																		
XS4FC411-35	XS411-35	2 3/16	7 1/8	5	6	4 1/4	35/64	2 3/16	25/32	9/16	1 25/32	3		2.937	1.126	1.811			1/2	
			181	127	152.4	107.8	14	55.6	19.5	14.3	45.2	76.1	1/2-13UNC	74.6	28.6	46			M12	
XS4FC413-39	XS413-39	2 7/16																		
XS4FC413-40	XS413-40	2 1/2	7 5/8	5.5	6 1/2	4 19/32	35/64	2 1/2	15/16	5/8	1 27/64	3 7/16		3.205	1.252	1.953			1/2	
XS4FC413	XS413	65	194	139.7	165.1	116.7	14	63.5	23.8	15.9	36.1	87.4	1/2-13UNC	81.4	31.8	49.6			M12	
XS4FC415-43	XS415-43	2 11/16																		
XS4FC415-44	XS415-44	2 3/4																		
XS4FC415-47	XS415-47	2 15/16																		
XS4FC415	XS415	75																		
XS4FC415-48	XS415-48	3																		
XS4FC415-48	XS415-48	3																		
XS4FC418-55	XS418-55	3 7/16																		
XS4FC418-56	XS418-56	3 1/2	10 1/4	7.375	8 5/8	6 3/32	29/32	3	1 15/32	15/16	1 33/64	4 5/32		4.079	1.516	2.563			3/4	
XS4FC418	XS418	90	260	187.32	219.1	154.9	23	76.2	37.7	23.8	38.5	105.6	3/4-10UNC	103.6	38.5	65.1			M20	
XS4FC420	XS420	100																		
XS4FC420-63	XS420-63	3 15/16	10 7/8	8.125	9 3/8	6 5/8	29/32	3 1/2	1 19/32	1 1/8	1 29/32	4 9/16		4.484	1.626	2.858			3/4	
XS4FC420-64	XS420-64	4	276	206.37	238.1	168.43	23	88.9	40.5	28.6	48.4	115.9	3/4-10UNC	113.9	41.3	72.6			M20	



Take-Up Units



XST
d 50 ~ 90 mm

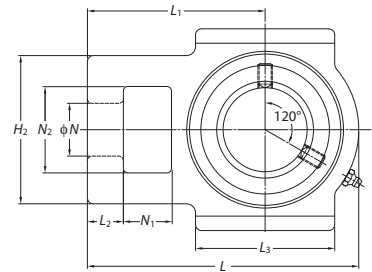
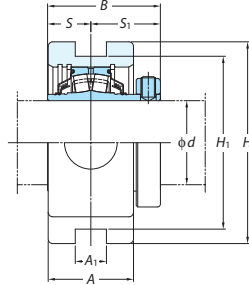

Unit No.	Bearing No.	Shaft Dia. inch mm d	Dimensions inch mm															
			A	A ₁	H	H ₁	H ₂	L	L ₁	L ₂	L ₃	N	N ₁	N ₂	B	S	S ₁	
XST410-31	XS410-31	1 15/16																
XST410	XS410	50	2	11/16	4 3/4	4	3 5/16	6 3/16	3 15/16	15/16	3 5/8	1 1/8	3/4	1 15/16	2.843	1	1.843	
XST410-32	XS410-32	2	50.8	17.5	120.7	101.6	84.1	157.2	100	23.8	92.1	28.6	19.1	49.2	72.2	25.4	46.8	
XST411	XS411	55	2 7/32	13/16	5 1/4	4 1/2	3 27/32	7 1/16	4 5/8	15/16	3 5/8	1 3/8	1 1/4	2 1/4	2.937	1.126	1.811	
XST411-35	XS411-35	2 3/16	56.4	20.6	133.4	114.3	98	179.4	117.5	23.8	92	34.9	31.8	57.2	74.6	28.6	46	
XST413-39	XS413-39	2 7/16																
XST413-40	XS413-40	2 1/2	2 7/16	1 1/16	5 7/8	5 1/8	4 1/4	7 25/32	5	15/16	4 3/8	1 3/8	1 1/4	2 1/2	3.205	1.252	1.953	
XST413	XS413	65	61.9	27	149.2	130.2	108	198	127	23.8	111	34.9	31.8	63.5	81.4	31.8	49.6	
XST415-43	XS415-43	2 11/16																
XST415-44	XS415-44	2 3/4	2 11/16	1 13/16	6 11/16	5 15/16	4 7/8	8 7/8	5 3/4	1 1/8	4 1/2	1 5/8	1 1/2	2 3/4	3.594	1.252	2.343	
XST415-47	XS415-47	2 15/16	68.3	46	169.9	150.8	123.8	225.4	146.1	28.6	114.3	41.3	38.1	69.9	91.3	31.8	59.5	
XST415	XS415	75																
XST415-48	XS415-48	3																
XST418-55	XS418-55	3 7/16																
XST418-56	XS418-56	3 1/2	3 1/6	1 13/16	7 13/16	6 13/16	5 1/8	10 1/16	6 3/8	1 1/16	5 1/2	1 7/8	1 5/8	2 7/8	4.079	1.516	2.563	
XST418	XS418	90	77.8	46	198.4	173	130.2	255.6	161.9	27	139.7	47.6	41.3	73	103.6	38.5	65.1	





TwoBolt Base Pillow Block Units

XS2P

d 40 ~ 100 mm

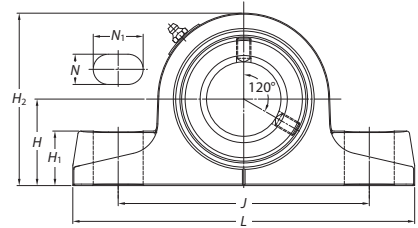
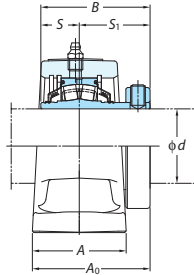
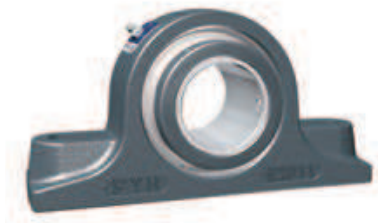

Unit No.	Bearing No.	Shaft Dia. inch mm d	Dimensions inch mm											Bolt Size inch mm			
			H	L	A	J	N	N ₁	H ₁	H ₂	A ₀	B	S		S ₁		
XS2P408-22	XS408-22	1 3/8															
XS2P408-23	XS408-23	1 7/16	1 7/8	6 7/8	2 5/32	5 9/32	1 9/32	1 3/32	1 1/4	3 3/4	2 5/8	2.531	1	1.531			
XS2P408-24	XS408-24	1 1/2	47.6	175	55	134	15	28	32	95.6	66.4	64.3	25.4	38.9			
XS2P408	XS408	40															
XS2P409-27	XS409-27	1 11/16															
XS2P409-28	XS409-28	1 3/4	2 1/8	7 3/8	2 3/8	5 25/32	1 9/32	1 3/32	1 5/16	4 1/4	2 27/32	2.657	1	1.657			
XS2P409	XS409	45	54	187	60	147	15	28	33	108	72.1	67.5	25.4	42.1			
XS2P410-31	XS410-31	1 15/16															
XS2P410	XS410	50	2 1/4	8 3/8	2 7/16	6 17/32	2 5/32	1 5/16	1 3/8	4 1/2	3 1/16	2.843	1	1.843			
XS2P410-32	XS410-32	2	57.2	213	62	166	20	33	35	114	77.8	72.2	25.4	46.8			
XS2P411	XS411	55															
XS2P411-35	XS411-35	2 3/16	2 1/2	8 7/8	2 5/8	6 7/8	2 5/32	1 3/16	1 5/8	4 31/32	3 1/8	2.937	1.126	1.811			
XS2P413-39	XS413-39	2 7/16															
XS2P413-40	XS413-40	2 1/2	2 3/4	9 1/4	2 7/8	7 9/32	2 5/32	1 3/16	1 25/32	5 19/32	3 3/8	3.205	1.252	1.953			
XS2P413	XS413	65	69.8	235	73	185	20	30	45	142	86.1	81.4	31.8	49.6			
XS2P415-43	XS415-43	2 11/16															
XS2P415-44	XS415-44	2 3/4															
XS2P415-47	XS415-47	2 15/16	3 1/4	10 7/16	3	8 9/32	1 5/16	1 9/32	1 7/8	6 3/8	3 13/16	3.594	1.252	2.343			
XS2P415	XS415	75	82.6	265	76	210	24	32	48	161.9	97	91.3	31.8	59.5			
XS2P415-48	XS415-48	3															
XS2P418-55	XS418-55	3 7/16															
XS2P418-56	XS418-56	3 1/2	3 3/4	13	3 3/8	10 5/16	1 1/16	1 23/32	2 1/4	7 15/32	4 1/4	4.079	1.516	2.563			
XS2P418	XS418	90	95.2	330	86	262	27	44	57	189.5	108.1	103.6	38.5	65.1			
XS2P420	XS420	100															
XS2P420-63	XS420-63	3 15/16	4 1/4	15 1/4	3 3/4	11 1/4	1 5/32	2 5/16	2 17/32	8 11/32	4 23/32	4.484	1.626	2.858			
XS2P420-64	XS420-64	4	108	387	95	286	29	59	64	212	120.1	113.9	41.3	72.6			



FourBolt Base Pillow Block Units

XS4P, XDS4P
d 65 ~ 100 mm

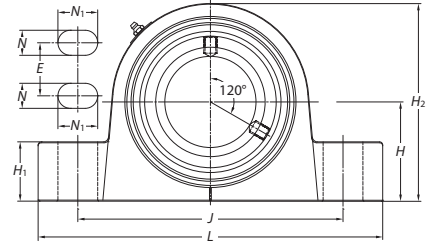
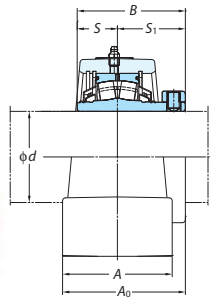
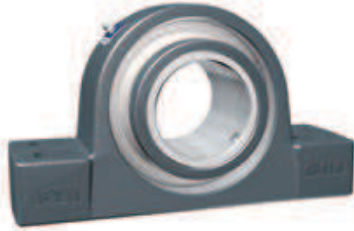

Unit No.	Bearing No.	Shaft Dia. inch mm <i>d</i>	Dimensions													Bolt Size inch mm
			<i>H</i>	<i>L</i>	<i>A</i>	<i>J</i>	<i>N</i>	<i>N</i> ₁	<i>E</i>	<i>H</i> ₁	<i>H</i> ₂	<i>A</i> ₀	<i>B</i>	<i>S</i>	<i>S</i> ₁	
XS4P413-39	XS413-39	2 7/16	2 3/4	9 1/4	3 3/8	7 1/8	19/32	3/4	1 3/4	1 5/8	5 19/32	3 21/32	3.205	1.252	1.953	1/2
XS4P413-40	XS413-40	2 1/2														
XS4P413	XS413	65														
XS4P415-43	XS415-43	2 11/16	3 1/4	10 7/16	3 3/4	8 1/8	25/32	29/32	1 7/8	1 7/8	6 3/8	4 7/32	3.594	1.252	2.343	5/8
XS4P415-44	XS415-44	2 3/4														
XS4P415-47	XS415-47	2 15/16														
XS4P415	XS415	75														
XS4P415-48	XS415-48	3														
XS4P418-55	XS418-55	3 7/16	3 3/4	13	4 1/8	10	15/16	1 1/2	2	2 1/4	7 9/16	4 5/8	4.079	1.516	2.563	3/4
XS4P418-56	XS418-56	3 1/2														
XS4P418	XS418	90														
XS4P420	XS420	100														
XS4P420-63	XS420-63	3 15/16	4 1/4	15 1/4	4 1/2	12 1/2	15/16	1 17/32	2 1/4	2 7/16	8 3/8	5 3/32	4.484	1.626	2.858	3/4
XS4P420-64	XS420-64	4														

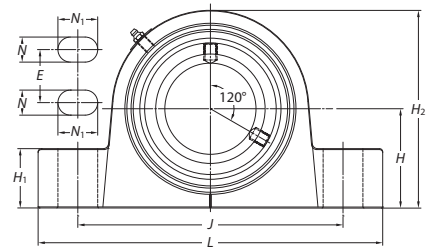
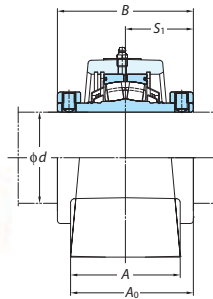
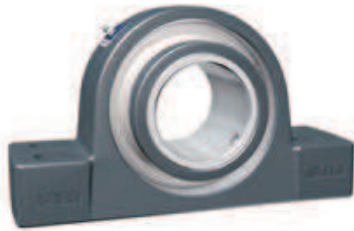

Unit No.	Bearing No.	Shaft Dia. inch mm <i>d</i>	Dimensions													Bolt Size inch mm
			<i>H</i>	<i>L</i>	<i>A</i>	<i>J</i>	<i>N</i>	<i>N</i> ₁	<i>E</i>	<i>H</i> ₁	<i>H</i> ₂	<i>A</i> ₀	<i>B</i>	<i>S</i> ₁		
XDS4P413-39	XDS413-39	2 7/16	2 3/4	9 1/4	3 3/8	7 1/8	19/32	3/4	1 3/4	1 5/8	5 19/32	3 21/32	3.906	1.953	M12	
XDS4P413-40	XDS413-40	2 1/2														
XDS4P413	XDS413	65														
XDS4P415-43	XDS415-43	2 11/16	3 1/4	10 7/16	3 3/4	8 1/8	25/32	29/32	1 7/8	1 7/8	6 3/8	4 7/32	4.686	2.343	M16	
XDS4P415-44	XDS415-44	2 3/4														
XDS4P415-47	XDS415-47	2 15/16														
XDS4P415	XDS415	75														
XDS4P415-48	XDS415-48	3														
XDS4P418-55	XDS418-55	3 7/16	3 3/4	13	4 1/8	10	15/16	1 1/2	2	2 1/4	7 9/16	4 5/8	5.126	2.563	M20	
XDS4P418-56	XDS418-56	3 1/2														
XDS4P418	XDS418	90														
XDS4P420	XDS420	100														
XDS4P420-63	XDS420-63	3 15/16	4 1/4	15 1/4	4 1/2	12 1/2	15/16	1 17/32	2 1/4	2 7/16	8 3/8	5 3/32	5.716	2.858	M20	
XDS4P420-64	XDS420-64	4														





Nomenclature

The nomenclature of a FYH Spherical Roller Unit is comprised of the roller bearing unit model code which is made up using the bearing model code and the housing model code. This in combination with the diameter series code, bore diameter code, accessory code and any special

code for individual applications determines the FYH Spherical Roller Units part number.



http://www.fyhbearings.com/html/nomenclature_r.html

FYH Spherical Roller Units

X	S	E2P	4	10	- 32	F	**	-----
----------	----------	------------	----------	-----------	-------------	----------	-----------	--------------

Bearing No. _____	XS410-32
Housing No. _____	E2P10

EXPANSION Type

Bore Size (inch)
Number of 1/16" of Inches
(ex. 39 = 2 7/16")

Bore Size (base)
Metric type x 5 mm of Number
(ex. 13 = 65 mm)

Series code
4 Spherical Roller

Housing model code
2P 2 - Bolt Pillow Block
4P 4 - Bolt Pillow Block
4F 4 - Bolt Flange
4FC Flange Cartridge
T Take - Up
E2P 2 - Bolt Pillow Block : TYPE E (inch)

INSERT-2 model code
S Spherical Roller
T Taper Roller

INSERT-1 Locking Type code
X Concentric set screw lock (One side)
XD Concentric set screw lock (both side)

Engineering Information of FYH Spherical Roller Bearings

Spherical Roller Bearing Life Calculations

The relationship between the basic rating life, the basic dynamic load rating, and the dynamic equivalent load of the spherical roller bearing is indicated in Formula A. If the spherical roller bearing unit is being used at a fixed rotating speed, the life is indicated as time. This is shown in Formula B.

$$A. L_{10} = \left(\frac{C_r}{P_r} \right)^{\frac{10}{3}}$$

$$B. L_{10h} = \frac{10^6 L_{10}}{60n} = \frac{10^6}{60n} \left(\frac{C_r}{P_r} \right)^{\frac{10}{3}}$$

L_{10} : Basic Rating Life 10⁶ rotations
 L_{10h} : Rated Life (hr)
 C_r : Basic Dynamic Load Rating (lbs)
 P_r : Dynamic equivalent Load (lbs)
 n : Speed (min⁻¹)

Basic Loads (lbs)		
Size Code	Dynamic C_r	Static C_{0r}
XS408	19967	22744
XS409	20834	24491
XS410	21683	26306
XS411	27191	33029
XS413	39006	49591
XS415	42032	54986
XS418	63910	86343
XS420	81897	111863

Limiting Speed for Seals		
Size Code	Standard Triple Lip Seal Limiting Speeds (dn=110,000) RPM	Non Contact Seal Limiting Speeds (dn=130,000) RPM
XS408	2750	3200
XS409	2450	2800
XS410	2200	2600
XS411	2000	2360
XS413	1692	2000
XS415	1460	1730
XS418	1220	1440
XS420	1100	1300



Allowable Radial Load (lbs) at Various RPM																				
Shaft Size	Size	L ₁₀ hours	RPM																	
			50	100	150	300	500	750	1000	1200	1400	1600	1800	2000	2200	2400	2600	2800	3000	3200
1 3/8" 1 7/16" 1 1/2" 40 mm	XS408	10000	7197	5846	5177	4205	3607	3194	2930	2774	2649	2545	2456	2380	2313	2253	2200	2151	2107	2067
		25000	5468	4441	3932	3194	2740	2426	2226	2107	2012	1933	1866	1808	1757	1712	1671	1634	1601	1570
		50000	4441	3607	3194	2594	2226	1971	1808	1712	1634	1570	1516	1468	1427	1390	1357	1327	1300	1275
		70000	4015	3261	2887	2345	2012	1782	1634	1547	1477	1419	1370	1327	1290	1257	1227	1200	1175	1153
		100000	3607	2930	2594	2107	1808	1601	1468	1390	1327	1275	1231	1193	1159	1129	1102	1078	1056	1036
1 11/16" 1 3/4" 45 mm	XS409	10000	7510	6100	5401	4387	3764	3333	3057	2894	2764	2655	2563	2483	2413	2351	2295	2245		
		25000	5705	4634	4103	3333	2859	2532	2322	2199	2099	2017	1947	1886	1833	1786	1744	1705		
		50000	4634	3764	3333	2707	2322	2056	1886	1786	1705	1638	1581	1532	1489	1451	1416	1385		
		70000	4189	3402	3013	2447	2099	1859	1705	1615	1542	1481	1430	1385	1346	1311	1280	1252		
		100000	3764	3057	2707	2199	1886	1670	1532	1451	1385	1331	1285	1245	1209	1178	1150	1125		
1 15/16" 2" 50 mm	XS410	10000	7816	6349	5621	4566	3917	3469	3182	3012	2876	2763	2667	2584	2512	2447	2389			
		25000	5937	4823	4270	3469	2976	2635	2417	2288	2185	2099	2026	1963	1908	1859	1815			
		50000	4823	3917	3469	2817	2417	2140	1963	1859	1775	1705	1646	1595	1550	1510	1474			
		70000	4360	3541	3136	2547	2185	1935	1775	1680	1604	1541	1488	1442	1401	1365	1332			
		100000	3917	3182	2817	2288	1963	1738	1595	1510	1442	1385	1337	1295	1259	1226	1197			
2 3/16" 55 mm	XS411	10000	9801	7961	7049	5726	4912	4350	3990	3778	3607	3465	3345	3241	3150					
		25000	7446	6048	5355	4350	3732	3304	3031	2870	2740	2632	2541	2462	2393					
		50000	6048	4912	4350	3533	3031	2684	2462	2331	2226	2138	2064	2000	1943					
		70000	5467	4441	3932	3194	2740	2426	2226	2107	2012	1933	1866	1808	1757					
		100000	4912	3990	3533	2870	2462	2180	2000	1893	1808	1737	1676	1624	1579					
2 7/16" 65 mm	XS413	10000	14060	11421	10113	8214	7047	6240	5724	5419	5174	4971	4798	4649						
		25000	10681	8676	7682	6240	5353	4740	4348	4117	3931	3776	3645	3532						
		50000	8676	7047	6240	5068	4348	3850	3532	3344	3193	3067	2961	2869						
		70000	7843	6370	5641	4582	3931	3480	3193	3023	2886	2773	2677	2593						
		100000	7047	5724	5068	4117	3532	3127	2869	2716	2593	2491	2405	2330						
2 11/16" 2 15/16" 75 mm	XS415	10000	15151	12307	10897	8851	7594	6724	6168	5840	5576	5357								
		25000	11510	9349	8278	6724	5768	5108	4685	4436	4236	4069								
		50000	9349	7594	6724	5461	4685	4149	3806	3603	3440	3305								
		70000	8451	6864	6078	4937	4236	3750	3440	3257	3110	2988								
		100000	7594	6168	5461	4436	3806	3370	3091	2927	2794	2685								
3 7/16" 90 mm	XS418	10000	23037	18712	16569	13458	11546	10224	9378	8879	8478									
		25000	17500	14215	12587	10224	8771	7766	7124	6745	6440									
		50000	14215	11546	10224	8304	7124	6308	5787	5479	5231									
		70000	12850	10437	9242	7507	6440	5703	5231	4953	4729									
		100000	11546	9378	8304	6745	5787	5124	4700	4450	4249									
3 15/16" 100 mm	XS420	10000	29521	23979	21232	17246	14796	13101	12018	11378	10864									
		25000	22426	18215	16129	13101	11240	9952	9129	8643	8253									
		50000	18215	14796	13101	10641	9129	8084	7415	7021	6703									
		70000	16467	13375	11843	9620	8253	7308	6703	6347	6060									
		100000	14796	12018	10641	8643	7415	6566	6023	5703	5445									

- Blue area: The Standard Triple Lip Seal is used.
- Green area: A non-contact seal is used.





FYH Mounted Spherical Roller Bearing Installation Guide

PRECAUTIONS

- Read the entire installation guide prior to beginning.
- Bearings are precision instruments and they must always be handled carefully to prevent damage.
- Store bearings in a cool and dry location, and always leave bearings in original packaging until ready for installation.
- Bearing life calculations should be performed prior to installation to ensure that the selected unit is acceptable for the application.
- The use of more than two bearings on a single shaft is not recommended.
- To maximize the life of the bearing avoid mis-alignment and pre-loading by carefully following these instructions.
- Always lock out the power source and adhere closely to industry safety standards before performing any work on the equipment.

PREPARATION

The mounting surface and housing base must be clean, flat, and of sufficient thickness to support the weight of the entire assembly without deflecting or breaking. Make sure that the mounting surface is parallel to the plane of the shaft for pillow blocks, and perpendicular to the shaft for flanges and take-up units. FYH mounted bearings can accommodate up to ± 2 degrees of mis-alignment, however longer bearing life can be achieved if mis-alignment can be minimized during installation.

Check the shaft diameter and make sure that it is within tolerance as indicated in Table 1. Check that the shaft is straight, clean, and free of burrs or other imperfections. Use emery cloth or a fine file to smooth the surface as necessary. A small amount of lubricant may be applied to both the shaft and the bore of the bearing; however lubricant should not be applied to the areas where the bearing locking mechanism contacts the shaft. To ensure adequate locking power between the bearing and shaft the hardness of the shaft should not exceed Rc 45.

Table 1 - Shaft Tolerance					
Shaft Size (mm)		h6		h7	
		Shaft Speed Greater Than 50% of Max RPM Rating		Shaft Speed Less Than 50% of Max RPM Rating	
Over	Incl.	Max (mm)	Min (mm)	Max (mm)	Min (mm)
30	50	+0	-0.016	+0	-0.025
50	80	+0	-0.019	+0	-0.03
80	120	+0	-0.022	+0	-0.035
120	180	+0	-0.025	+0	-0.04

Converting units from fixed to expansion

FYH mounted roller units are capable of operating in both a fixed or expansion configuration.

Before bearing installation

On the back side of the unit (opposite the housing markings), remove the bearing retaining ring located on the inner diameter of the housing and move it back to the groove on the outer position of the housing. Slide the bearing insert rearward within the housing until it sits against the retaining ring that was just relocated. When ready for installation, slide the insert forward in the housing approximately one thirty-second of an inch ($1/32''$) and alternately tighten the set screws onto the shaft to the specified torque setting as shown in Table 4.

After bearing installation

Before performing any work on the bearing, lock out the power source and allow the shaft and adjacent machinery to cool down to ambient temperature. Loosen the set screws or other locking mechanism to allow the shaft to move freely within the bore then follow the same procedures explained in the "Before bearing installation" section.

FYH Mounted Spherical Roller Bearing Installation Guide



INSTALLATION

1. Slide the unit onto the shaft while holding the inner ring of the bearing.

Position the unit on the mounting surface so that the plane of the shaft is perpendicular to the face of the housing, and alternately tighten the mounting bolts to the specified torque as shown in Table 2.

Make sure to use bolts, washers, and nuts of sufficient strength and grade rating for the application.

2. Check the final position of the shaft and alternately tighten the set screws of the non-expansion unit onto the shaft to the specified torque setting as shown in Table 3. The set screws in the bearing on the opposite side of the shaft should line up with the set screws of the bearing that was installed first (See Figure A). Expansion bearings should be installed only after the shaft and adjacent machinery has cooled down to the ambient temperature.

After positioning the expansion unit on the shaft slide the insert to the rearmost position within the housing until it seats against the retaining ring. Then slide the insert forward in the housing approximately one thirtysecond of an inch (1/32") and alternately tighten the set screws onto the shaft to the specified torque setting as shown in Table 3. Allowable shaft expansion and expansion calculation data can be found in Table 4 and Formula 1 respectively.

3. Once installed, slowly rotate the bearing by hand to confirm that it turns smoothly and without resistance, vibration, or any other abnormalities.

Table 2 - Mounting Bolt Tightening Torque

Bolt Size		Tightening Torque		
mm	inch	N-m	in-lbf	ft-lbf
M6	1/4	5	43	4
M8	5/16	10	92	8
M10	3/8	22	196	17
M12	1/2	38	334	27
M16	5/8	95	840	70
M18	—	139	1231	103
M20	3/4	189	1664	139
M22	7/8	260	2301	192
M27	1	484	4277	358

Table 3 - Set Screw Tightening Torque

Size Code	Set Screw Size	N-m	in-lbf	ft-lbf
XS408	5/16-28 UNF x 1/2	14.5	128	11
XS409				
XS410	3/8-24 UNF x 5/8	25.5	226	19
XS411				
XS413				
XS415	1/2-20 UNF x 3/4	56.5	500	42
XS418				
XS420				

Table 4 - Allowable Shaft Expansion

Size Code	mm	inch
XS408	5	13/64
XS409	5	13/64
XS410	5	13/64
XS411	6	15/64
XS413	6	15/64
XS415	6	15/64
XS418	6	15/64
XS420	6	15/64

Formula 1 – Linear Shaft Expansion

$$L = A \cdot T \cdot D$$

L : Expansion of shaft (mm)
A : Linear expansion coefficient of shaft for ordinary steel (11.5 x 10⁻⁶)
T : Temperature increase (°C)
D : Installation distance between bearing units (mm)

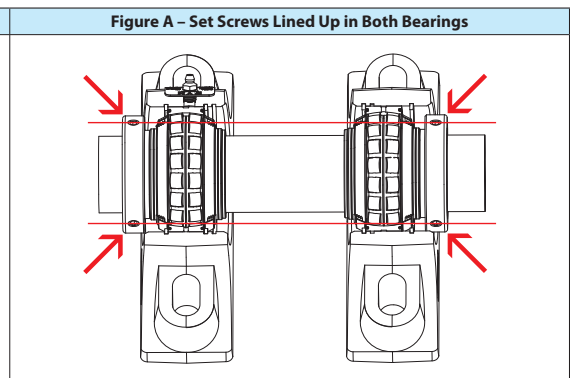

VIDEO IN INSTALLATION



Please scan the QR code with your mobile phone and watch a installation video. If you don't have the reader, get the QR Reader app at the app store. Or you can find it at our web site as well.



http://www.fyhbearings.com/html/tech_info.html#roller



FYH Mounted Spherical Roller Bearing Installation Guide

LUBRICATION

Proper lubrication practices will greatly extend the life of the bearing.

Bearings are factory lubricated with the proper amount and type of lubricant for most general purpose applications as well as many highly demanding operating environments, and except as recommended by FYH, no further lubrication is required upon installation.

Lubrication tips:

- The factory standard lubricant is a **calcium sulfonate** grease. Always use the same type of lubricant to avoid compatibility issues and other potential problems.
- When adding lubricant do so slowly and while the bearing is rotating until a small amount of lubricant can be seen coming out of the seals.
- At low speeds (below 200 RPM) it is acceptable to completely fill the bearing with grease.
- At moderate to high speeds it is not advisable to completely fill the bearing with grease as it could lead to overheating and reduced bearing life.
- It is generally better to use less lubrication more frequently than more lubricant less often.
- If the unit will not be operated for an extended period of time extra lubricant should be added to prevent corrosion.
- If the unit has not been operated for an extended period of time fresh lubricant should be added prior to start-up.
- If the unit becomes too hot during operation from over-lubrication remove the grease fitting and operate the unit for approximately thirty minutes to allow excess grease to purge.

Appropriate lubrication intervals can be determined by referring to Table 5; however experience should largely determine the actual lubrication regimen for a particular application. Consult with an FYH representative for assistance.

If a suitable Calcium Sulfonate lubricant is not available for re-lubrication then the following compatible lubricants may also be used:

Barium Complex, Calcium Stearate, Lithium Complex, Polyurea (Shear Stable)

The use of any other type of lubricant should be avoided to prevent compatibility issues with the Calcium Sulfonate grease that is originally supplied.

To find the proper lubrication interval in Table 5 obtain the relevant percentage of max allowable RPM by referring to Table 6. Example: XS411 with positive contact seals has a max RPM rating of 2000. If the application has an RPM of 600 then the percentage of max RPM is 30% ($600/2000 = .30$).

The amount of grease for replenishment can be found in Table 7.

Table 5 - Lubrication Schedule

Environment	Clean to Moderately Dirty				Clean to Moderately Dirty			Dirty to Very Dirty
Temperature (°C)	Under 120 degrees				Over 120 degrees			From -20 to 200
% of max allowable RPM	0 - 25%	25 - 50%	50 - 75%	75 - 100%	0 - 25%	25 - 50%	50 - 100%	0 - 100%
Lubrication interval	From three to eight months	From one to three months	From one week to one month	Daily to once per week	From two to six weeks	From one week to one month	Daily to once per week	Daily to once per week

Table 6 - Limiting Speed for Seals

Size Code	Standard Triple Lip Seal Limiting	Non Contact Seal Limiting
XS408	2750	3200
XS409	2450	2800
XS410	2200	2600
XS411	2000	2360
XS413	1692	2000
XS415	1460	1730
XS418	1220	1440
XS420	1100	1300

Table 7 - Grease Amount for Replenishment

Size Code	Amount of Grease (grams)
XS408	7-8
XS409	7-9
XS410	8-9
XS411	10-12
XS413	19-22
XS415	22-26
XS418	40-46
XS420	50-59





fyhbearings.com



FYH BEARING UNITS USA INC.

13201 FYH Drive,
Huntley Illinois 60142 USA
TEL: 847-487-9111 / FAX: 847-487-9222
E-mail: sales@fyhusa.com

NIPPON PILLOW BLOCK CO., LTD.

2306 Hirao Miharaku Sakai Osaka
587-0022 JAPAN
TEL: 072-361-3750 / FAX: 072-361-4173
E-mail: info@fyhbearings.com