

F18

General purpose filters
G1 1/2 & G2

- Direct ported filter with high water removal efficiency
- Highly visible, prismatic liquid level indicator lens
- High flow with minimal pressure drop
- Optional visual service life indicator turns from green to red when the filter element needs to be cleaned or replaced
- Optional electrical service indicator also available

Technical Data

Medium:
Compressed air

Max. operating pressure:
17 bar

Particle removal:
40 µm standard, 5 µm optional

Flow:
See below

Port size:
G1 1/2, G2

Drain:
Manual or automatic

Automatic drain operating conditions:
Drain closes when bowl pressure: > 0,3 bar
Drain opens when bowl pressure: ≤ 0,2 bar
Minimum air flow required to close drain: 1 dm³/s

Fluid/Ambient temperature:
-34 ... +80°C
Air supply must be dry enough to avoid ice formation at temperatures below +2°C.

Materials

Body, intermediate body and bowl:
Aluminum

Liquid level indicator:
Transparent nylon

Filter element:
Sintered bronze

Elastomers:
Neoprene and nitrile



● Technical data - standard models

Symbol	Port size	Filter element (µm)	Flow *1) (dm ³ /s)	Drain	Bowl	Weight (kg)	Model
	G1 1/2	40	765	Manual	Metal	6,7	F18-B00-M3DG
	G2	40	765	Manual	Metal	6,6	F18-C00-M3DG
	G1 1/2	40	765	Automatic	Metal	6,7	F18-B00-A3DG
	G2	40	765	Automatic	Metal	6,6	F18-C00-A3DG

*1) Typical flow with a 40 µm element at 6,3 bar inlet pressure and 0,5 bar pressure drop.

● Option selector

F18-★0★-★D★

Port size	Substitute	Thread	Substitute
1 1/2	B	PTF	A
2	C	ISO G	G
Service life indicator	Substitute	Filter element	Substitute
Without	0	5 µm	1
With (pneumatic)	1	40 µm	3
With (electrical)	4		
Drain	Substitute		
Automatic	A		
Manual, 1/4 turn	M		

F18

General purpose filters
G1 1/2 & G2

● Flow characteristics

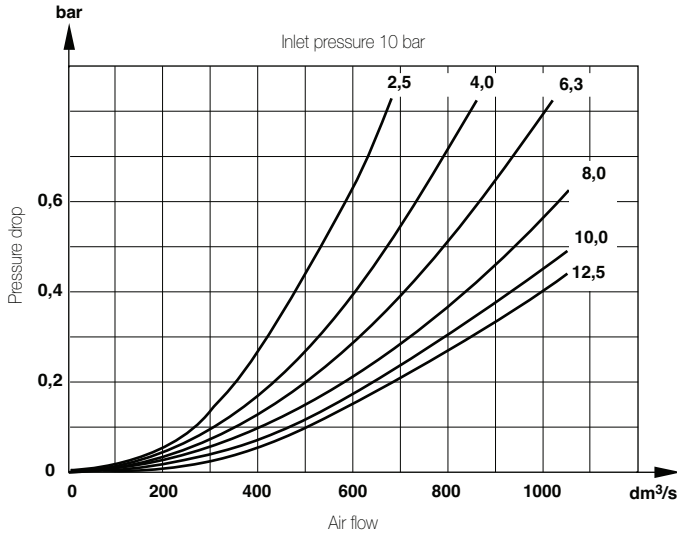

● Accessories

Service life indicator (pneumatic)



5797-50

Service life indicator (electrical)



4020-51

● Service kit

Service kit, automatic drain



F18-100A (40 µm)

F18-100A (5) (5 µm)

● Dimensions

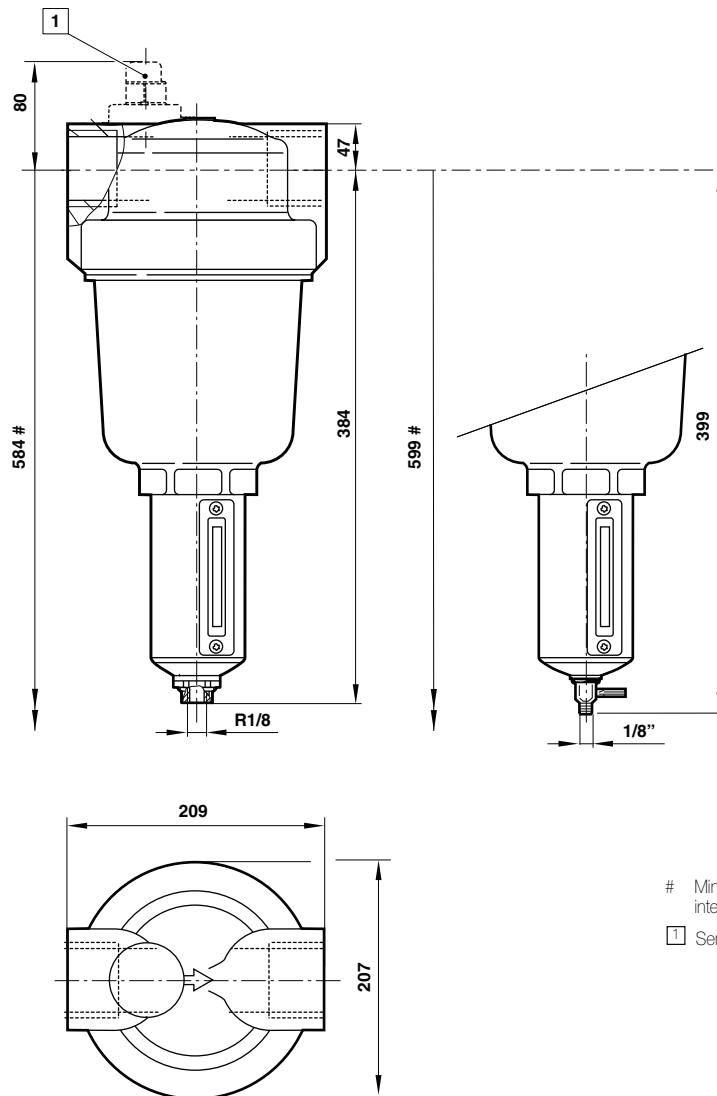

Min. clearance required to remove intermediate body and bowl

1 Services indicator optional