

SINGLE ACTING PANCAKE CYLINDERS, LOCK NUT, TILTING SADDLE, LOAD RETURN



- ✓ Capacity from 50 to 1.100 Tn, stroke up to 50 mm.
- ✓ Load return. Lock nut tested under 50% overload.
- ✓ The lock nut holds the load mechanically for extended periods of time.
- ✓ Hydraulic end of stroke overflow port. Without stop ring.
- ✓ Built-in tilting saddle to improve side load resistance.
- ✓ Special coating as standard to improve corrosion and side load resistance.
- ✓ Used in confined spaces.

Performance under Pressure

STR
Single Acting Lock Nut Cylinders



P.32

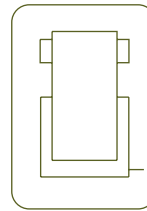

S/A LOCK NUT CYLINDERS



Type **STX**

Capacity **50 - 1.100 Tn**

Stroke **45 - 50 mm**

Max. pressure **700 bar**

STX CYLINDERS

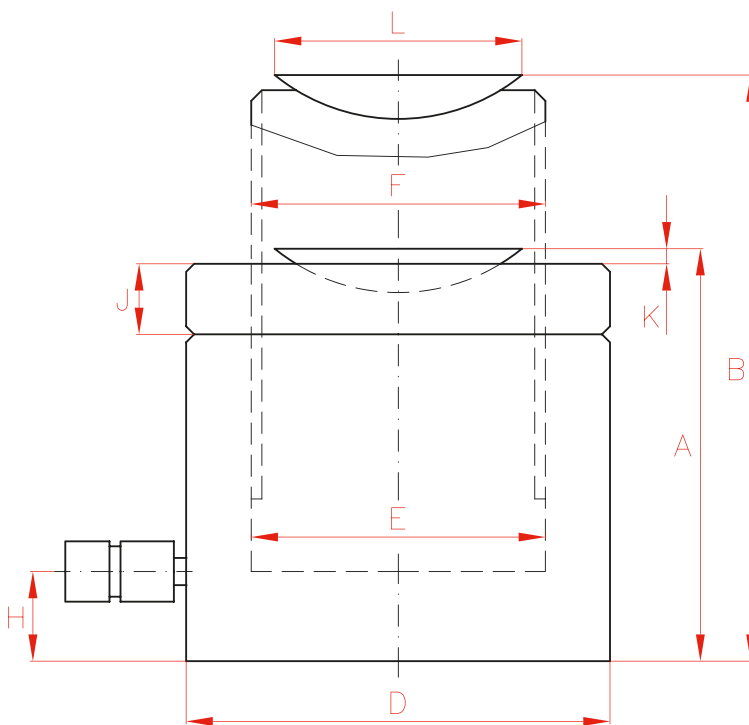

STX
Built-in Tilting Saddle



P.46

SX - SMX
Single Acting Low Profile Cylinders,
Load or Spring Return



P.28

Capacity		Stroke	Model	Oil Cap.	A	B	D	E	F	H	J	K	L	Area	Weight
Tn	kN	mm	LARZEP	cm ³	mm	mm	mm	mm	mm	mm	mm	mm	mm	cm ²	kg
50	486	50	STX05005	355	125	175	120	95	Tr 95x4	19	21	6	92	71	11
90	911	45	STX09004	597	137	182	165	130	Tr 130x6	21	31	8	126	133	22
140	1.380	45	STX14004	905	148	193	200	160	Tr 160x6	27	38	9	148	201	39
220	2.156	45	STX22004	1.413	155	200	255	200	Tr 200x6	28	40	10	157	314	62
350	3.468	45	STX35004	2.208	178	223	310	250	Tr 250x6	35	50	11	240	491	111
430	4.227	45	STX43004	2.771	184	229	340	280	Tr 280x6	35	55	10	260	616	126
550	5.520	45	STX56004	3.618	192	237	390	320	Tr 320x6	38	60	10	295	804	193
670	6.600	45	STX67004	4.330	236	281	430	350	Tr 350x6	50	75	15	295	962	259
880	8.620	45	STX88004	5.655	268	313	490	400	Tr 400x6	60	85	20	325	1.257	482
1.100	10.905	45	STX110004	7.157	295	340	550	450	Tr 450x6	65	95	25	400	1.590	532