

**Juntas universales
Tipo V**

Alta precisión con cojinete de agujas



Junta universal de precisión "alta velocidad" con cojinetes de agujas y bajo mantenimiento

DIN 7551

Ángulo máximo
Simple 45°
Doble 90°

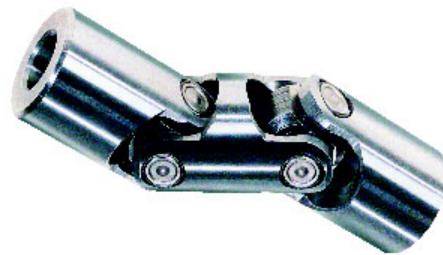
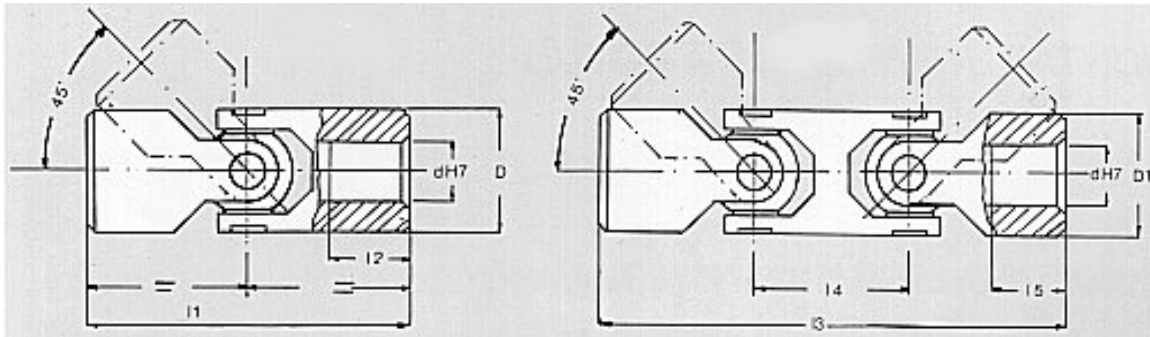

Tipo		d ^{H7}	D	l ₁	l ₂	D ₁	l ₃	l ₄	l ₅	b	t	s ^{H8}	W ^{H8}
S	D	mm	mm	mm	mm	mm	mm	mm	mm	mm	mm	mm	mm
102V		8	16	52	15					2	9		
103V	103DV	10	20	62	18	20	88	26	18	3	11,4	10	10
105V	105DV	14	25	74	20	25	104	33	20	5	16,3	14	14
106V	106DV	16	32	86	23	32	124	38	23	5	18,3	16	16
107V		18	37	72	17								
108V	108DV	20	40	108	30	40	156	48	30	6	22,8	20	20
109V		22	47	95	22								
110V	110DV	25	50	132	32	50	188	56	32	8	28,3	25	25
111V	111DV	30	63	166	38	63	238	80	38	8	33,3	30	30
112V	112DV	35	70	140	35	70	212	78	30	10	38,3		35
113V	113DV	40	80	180	50	80	290	120	48	12	43,3		35
114V	114DV	50	95	190	54	96	290	120	50	14	53,3		35

FORMA

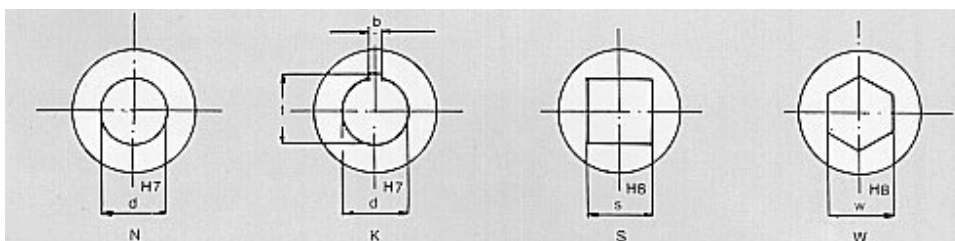



Juntas universales Tipo V

Conjunto cardan extensible con cojinete de agujas

Conjunto cardan extensible montado de juntas universales con cojinete de agujas

- Ejecución normal.
- Agujero redondo, con chavetero, hexágono o cuadrado.
- El eje estriado en la ejecución normal es trefilado.
- Bajo demanda puede ser fresado, templado y rectificado.

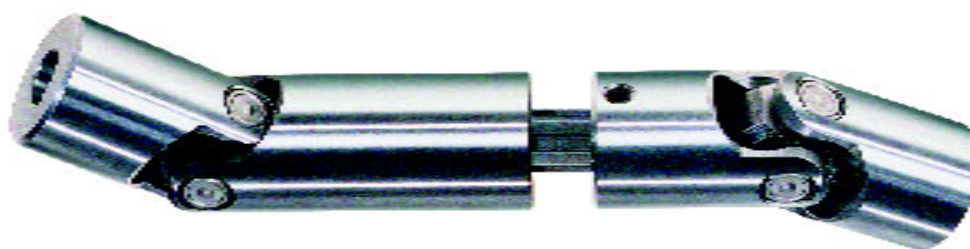
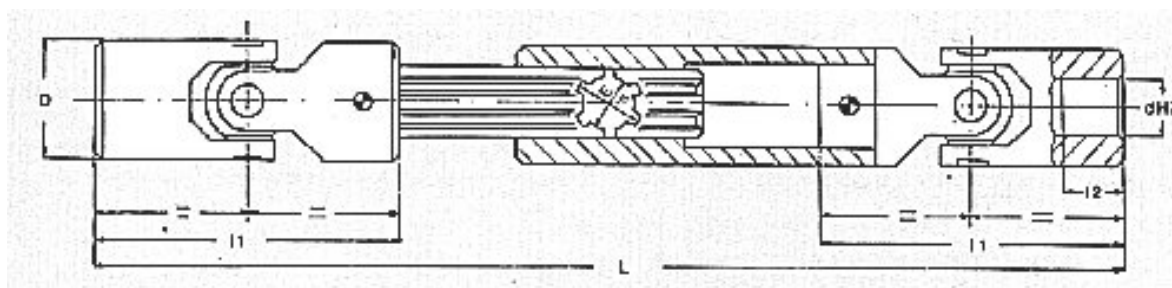

Medidas normalizadas

Tipo	D ^{H7} mm	D mm	l ₁ mm	l ₂ mm	bxt mm	s ^{H8} mm	SW ^{H8} mm	E mm	F mm	Lmin mm	Lmax mm
124V	8	16	52	15	2×9					146 186	166 246
125V	10	20	62	18	3×11,4	10	10	11	14	156 196	176 256
127V	14	25	74	20	5×16,3	14	14	13	16	187 237	217 307
128V	16	32	86	23	5×18,3	16	16	16	20	212 282	242 372
129V	18	37	72	17	6×20,8	17	18	16	20	195 270	225 370
130V	20	40	108	30	6×22,8	20	20	18	22	259 329	289 429
131V	22	47	95	22	6×24,8	22	22	21	25	250 330	280 430
132V	25	50	132	32	8×28,3	25	25	23	28	306 386	356 486
133V	30	63	166	38	8×33,3	30	30	32	38	386 466	456 576
134V	35	70	140	35	10×38,3		35	32	38		

Juntas universales Tipo A

Alta precisión DIN 808

Esta junta universal de "alta precisión" ha sido posible gracias a una esmerada construcción y de tolerancias ajustadísimas. Todas las partes de la articulación están templadas, rectificadas y lapeadas.

Ángulo máximo
Simple 45°
Doble 90°

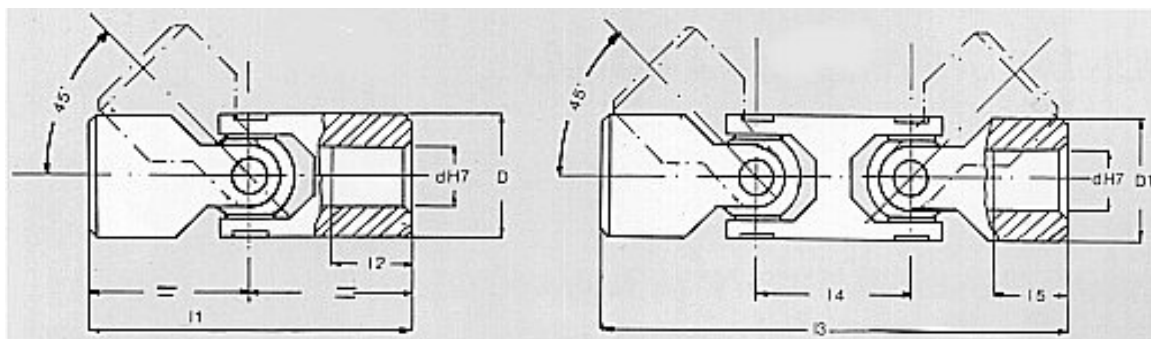

Tipo		d ^{H7}	D	l ₁	l _{1x}	l _{2x}	l ₂	D ₁	l ₃	l _{3x}	l ₄	l ₅	b	t	s ^{H8}	W ^{H8}
S	D	mm	mm	mm	mm	mm	mm	mm	mm	mm	mm	mm	mm	mm	mm	mm
101A	101AD	6	16	34			9	16	61		27					
102A	102AD	8	16	40	58		11	16	67		27		2	9		
103A	103AD	10	22	45	48	62	10	20	75		30		3	11,4	10	10
104A	104AD	12	25	50	56	74	11	22	74	86	29	15	4	13,8	12	12
105A	105AD	14	29	56	60	74	13	25	85	95	33	16	5	16,3	14	14
106A	106AD	16	32	65	68	86	15	29	100	104	35	19	5	18,3	16	16
107A	107AD	18	37	72	74	108	17	32	112	114	39	20	6	20,8	17	18
108A	108AD	20	40	82	108	127	19	40	127	128	46	20	6	22,8	20	20
109A	109AD	22	47	95	92	127	22	40	145		46	25	6	24,8	22	
110A	110AD	25	50	108	105	132	27	50	163		59	25	8	28,3	25	25
111A	111AD	30	58	122	166	178	30	58	182		66	30	8	33,3	30	30
111/1A	111/1AD	32	63	130			30	63	198		84	30	10	35,3	30	35
112A	112AD	35	70	140			35	70	212		78	30	10	38,3		35
113A	113AD	40	80	160			42	80	245		95	38	12	43,3		35
114A	114AD	50	95	190			54	95	290		120	50	14	53,8		35

l_{1x}, l_{2x}, l_{3x} longitud bajo demanda

FORMA

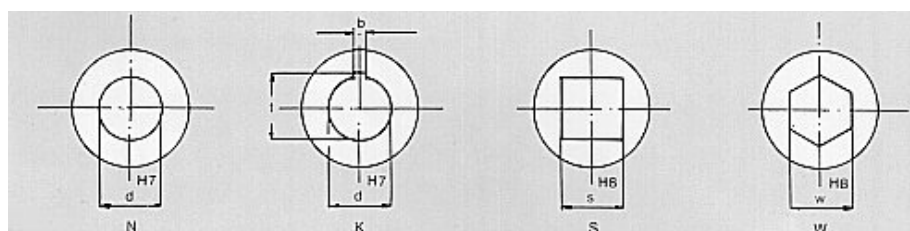



Juntas universales Tipo A

Conjunto cardan extensible

Conjunto cardan extensible montado
de juntas universales de precisión
DIN 808

- Ejecución normal.
- Agujero redondo, con chavetero, hexágono o cuadrado.
- El eje estriado en la ejecución normal es trefilado.
- Bajo demanda puede ser fresado, templado y rectificado.

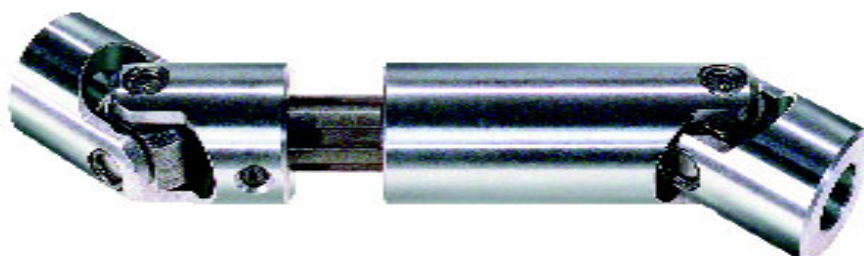
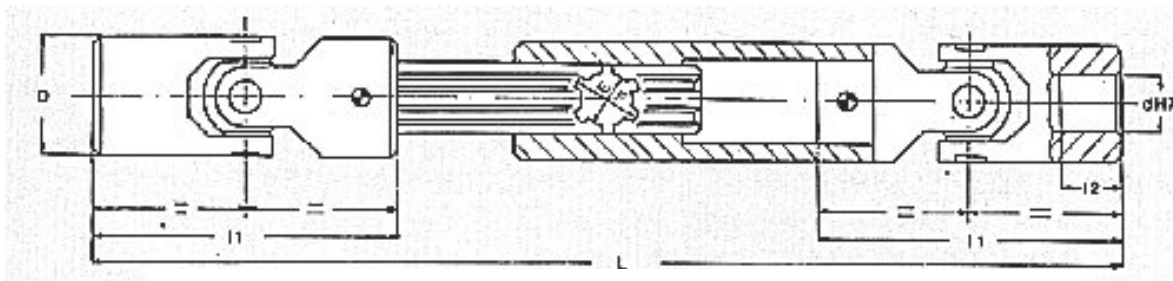

Tipo	D^{H7} mm	D mm	l_1 mm	l_2 mm	B mm	bxt mm	s^{H8} mm	SW^{H8} mm	E mm	F mm	Lmin mm	Lmax mm
125A	10	22	45	10	40	3×11,4	10	10	11	14	130 170	150 230
126A	12	25	50	11	45	4×13,8	12	12	13	16	140 200	170 270
127A	14	29	56	13	48	5×16,3	14	14	13	16	160 210	190 280
128A	16	32	65	15	50	5×18,3	16	16	16	20	180 250	210 340
129A	18	37	72	17	51	6×20,8	17	18	16	20	195 270	225 370
130A	20	40	82	19	56	6×22,8	20	20	18	22	220 290	250 390
131A	22	47	95	22	60	6×24,8	22	22	21	25	250 330	280 430
132A	25	50	108	27	69	8×28,3	25	25	23	28	270 350	320 450
133A	30	58	122	30	70	8×33,3	30	35	26	32	320 400	390 510
134A	35	70	140	35	70	10×38,3	36	35	32	38		
135A	40	80	160	42	70	12×43,3	41	35	42	48		
136A	50	95	190	54	70	14×53,3	50	35	42	48		

Juntas universales Tipo AL

Serie ligera

 Ángulo máximo
 Simple 45°
 Doble 90°

La junta universal de la serie ligera es para trabajos de medias y bajas revoluciones.

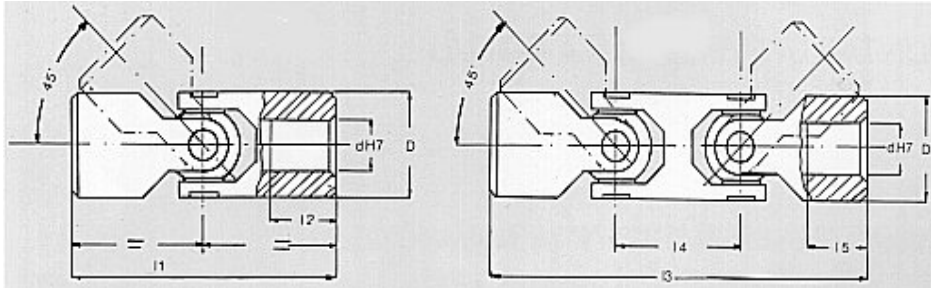

Tipo		d ^{H7}	D	D ₁	I ₁	I _{1x}	I _{2x}	I ₂	I ₃	I _{3x}	I ₄	I ₅	S	SW	b×t
S	D	mm	mm	mm	mm	mm	mm	mm	mm	mm	mm	mm	mm	mm	mm
100		5	10		40			13							
101AL	101ADL	6	13	13	40			13	63		23	13	6		
102AL	102ADL	8	16	16	40			10	67		27	10	8		2×9
103AL	103ADL	10	20	20	45	48	62	10	74		29	10	10	10	3×11,4
104AL	104ADL	12	25	22	50	56	74	11	74	86	29	11	12	12	4×13,8
105AL	105ADL	14	29	25	56	60	74	13	85	95	33	13	14	14	5×16,3
106AL	106ADL	16	32	29	65	68	86	15	100	104	35	19	16	16	5×18,3
107AL	107ADL	18	37	32	72	74		17	112	114	39	20	18	18	6×20,8
108AL	108ADL	20	40	40	82	108		19	128	127	46	19	20	20	6×22,8
109AL	109ADL	22	47	40	95	92		22	145		46	25	22		6×24,8
110AL	110ADL	25	50	50	108	105	132	27	163		59	24	25	25	8×28,3
111AL	111ADL	30	58	58	122	166		30	182		66	30	30	30	8×33,8

 I_{1x}, I_{2x}, I_{3x} longitud bajo demanda

Juntas universales

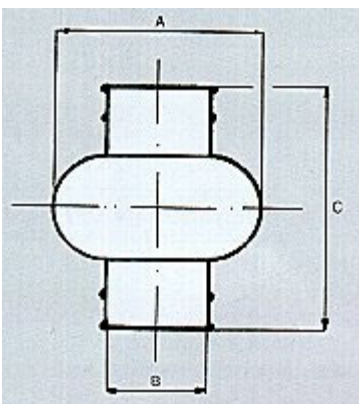
Cubierta Protectora flexible

Tipo	ø est. Junta	Med. cubierta		
		A	B	C
103G	20/22	39	20,5	47
104G	25	47	24,5	52
105G	29	51	27,5	58
106G	32	56	30,5	67
107G	37	66	35,5	74
108G	40	75	40	84
109G	47	83	45	97
110G	50	93	50	110
111G	58	105	56	124



Juntas universales Tipo X

En acero inoxidable

Construidas en acero inoxidable X5Cr Ni1810 AISI 304

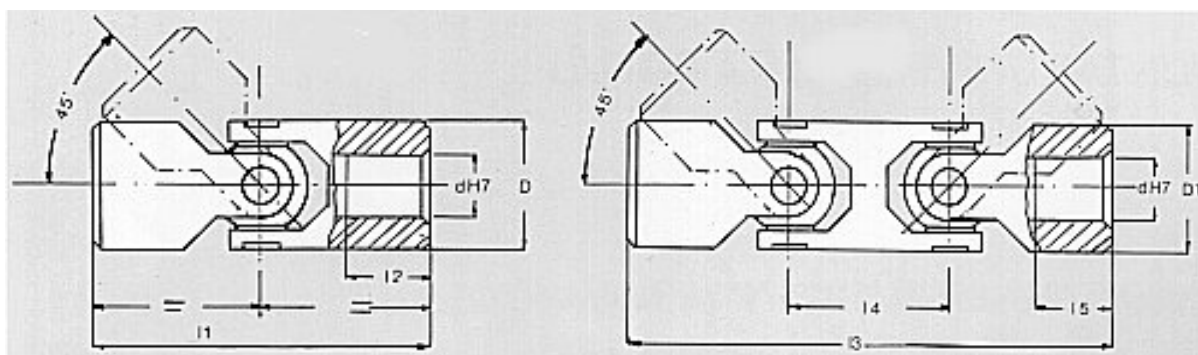

Junta simple 45°					Junta doble 90°						Acoplamientos bajo demanda		
Tipo	d ^{H7}	D	L1	L2	Tipo	d ^{H7}	D1	L3	L4	L5	S	SW	b×t
100X	5	10	44	15									
101X	6	13	50	18							6		
102X	8	16	58	19							8		2×9
103X	10	22	76	19							10	10	3×11,4
104X	12	25	86	29	104DX	12	22	105	29	29	12	12	4×13,8
105X	14	29	90	30	105DX	14	25	119	33	30	14	14	5×16,3
106X	16	32	95	30	106DX	16	29	125	35	30	16	16	5×18,3
107X	18	37	108	35	107DX	18	32	134	39	35	18	18	6×20,8
108X	20	40	108	32	108DX	20	40	154	46	32	20	20	6×22,8
109X	22	47	127	38	109DX	22	40	173	46	38	22		6×24,8
110X	25	50	140	44	110DX	25	50	199	59	44	25	25	8×28,3
111X	30	58	178	58	111DX	30	58	244	66	58	30	30	8×33,8

FORMA

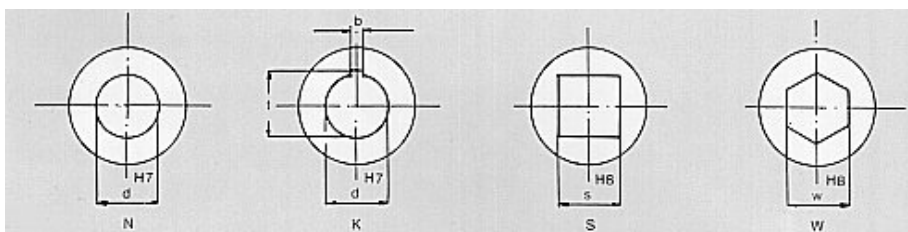



Juntas universales Tipo VR **Alta precisión con cojinete de agujas y cambio rápido**

Con rodamientos de agujas y cambio rápido

Ángulo máximo
Simple 45°
Doble 90°

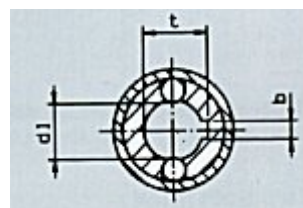
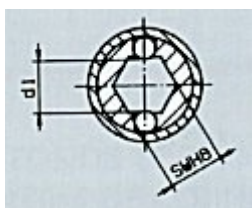
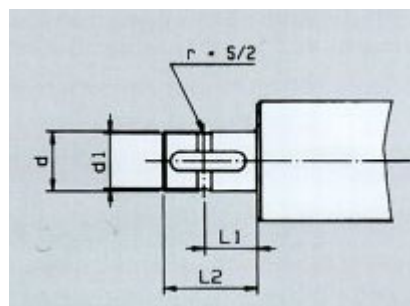
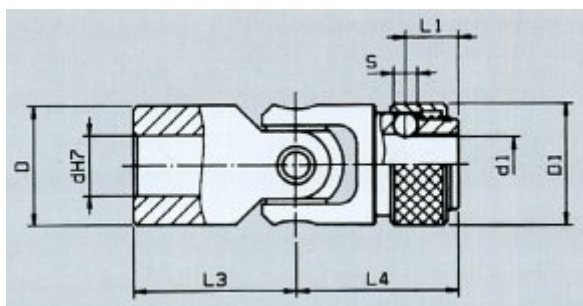

Tipo	d ^{H7} mm	D mm	d ₁ mm	D ₁ mm	l ₁	l ₂	l ₃	l ₄	S mm	b mm	t mm	SW ^{H8}	SW ₁ ^{H8}
102VR	8	16	6,3	16	9,5	15	26	26	3	2	9		
103VR	10	20	8,7	22	11,5	18	31	31	4	3	11,2	10	9,06
105VR	14	25	13	26,5	13,5	21	37	37	4	5	15,3	14	11,5
106VR	16	32	14,8	32,5	14	25	43	43	6,3	5	17,3	16	
107VR	18	37	16	37	19	33	36	50	8	6	19,8	18	
108VR	20	40	18	40,5	19	33	54	54	8	6	21,8	20	
109VR	22	47	20	47	20,5	38	47,5	60	10	6	23,8	22	
110VR	25	50	23	50,5	20,5	38	66	66	10	8	26,8	25	
111VR	30	63	28	63,5	25	50	83	83	10	8	32,2	30	

FORMA

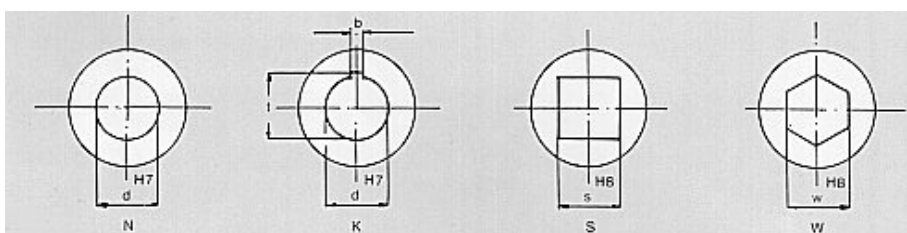



Juntas universales Tipo AR

Alta precisión con cambio rápido

Alta precisión y cambio rápido

Ángulo máximo
Simple 45°
Doble 90°

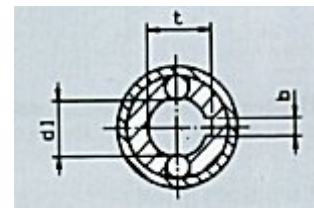
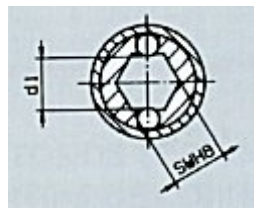
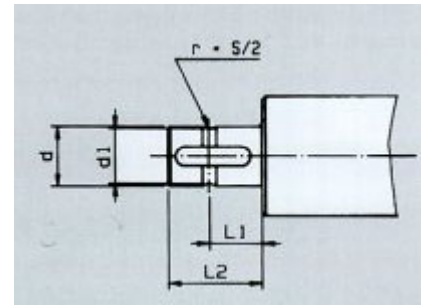
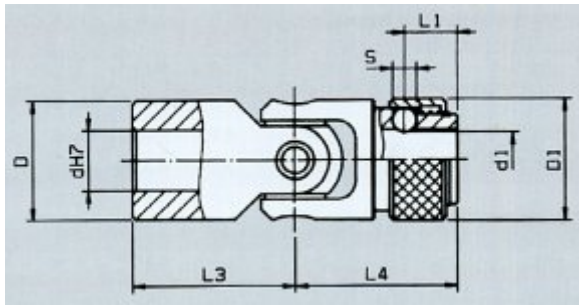

Tipo	d ^{H7} mm	D mm	d ₁ mm	D ₁ mm	l ₁	l ₂	l ₃	l ₄	S mm	b mm	t mm	SW ^{H8}	SW ₁ ^{H8}
103AR	10	22	8,7	22	11,5	17	22,5	31	4	3	11,2	10	9,06
104AR	12	25	11	26	13,5	21	25	37	4	4	13,3	12	
105AR	14	29	13	29	13,5	21	28	37	4	5	15,3	14	11,5
106AR	16	32	14,8	32	14	25	32,5	43	6,3	5	17,3	16	
107AR	18	37	16	37	19	33	36	50	8	6	19,8	18	
108AR	20	40	18	40	19	33	41	54	8	6	21,8	20	
109AR	22	47	20	47	20,5	38	47,5	60	10	6	23,8	22	
110AR	25	50	23	50	20,5	38	54	66	10	8	26,8	25	
111AR	30	58	28	58	25	50	61	83	10	8	32,2	30	

FORMA

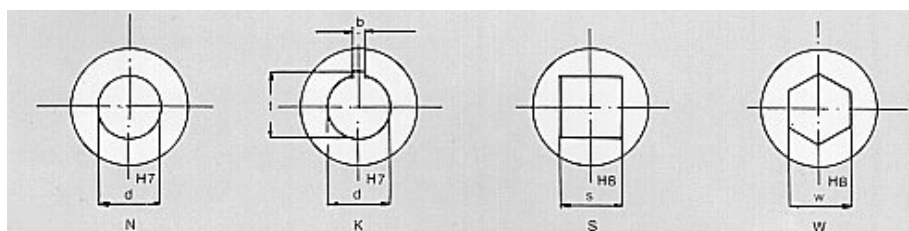



Juntas universales

**Criterios para escoger
las juntas adecuadas
a sus necesidades**



Las tablas presentan los pares de torsión máximos permitidos (expresadas en Kgm.), que han sido calculados tras un funcionamiento prolongado con un ángulo de inclinación de 10°. Si el ángulo de inclinación superase los 10°, los valores respectivos se reducirán de acuerdo a los factores de par de torsión indicados a continuación.

Ángulo A	Factor F
5°	1,25
10°	1
20°	0,75
30°	0,45
40°	0,30

Ejemplo

Criterios de elección de la junta apropiada, según la potencia que se quiere transmitir, la velocidad y el ángulo de inclinación.

Considerando:

- La potencia N 3CV
- La velocidad n 2000 revoluciones/min.
- El ángulo a 20°

El correspondiente momento de torsión es:

$$M_t = \frac{716,2 \times N}{n} = \frac{716,2 \times 3}{2000} = 1,074 \text{ Kgm.}$$

El par de torsión a transmitir es de 1,074 Kgm., pero puesto que el ángulo es de 20° habrá que elegir una junta de mayor dimensión, con un par de torsión más elevado. Puesto que el factor de par de torsión para 20° es de 0,75 (según lo indicado en la tabla), habrá que dividir el Mt por F:

$$\frac{M_t}{F} = \frac{1,074}{0,75} = 1,432 \text{ Kgm.}$$

La junta apropiada deberá tener un par de torsión de transmisión de 1,432 Kgm. que, según lo que indica la tabla de juntas de cojinetes, es del tipo 105V.

Hay que tener en cuenta que 1 Kgm. = 9,80665 Nm.



Juntas universales

Momentos de torsión para juntas cardan

Momentos de torsión (en Nm) para juntas cardan de precisión de casquillos

Tipo	VELOCIDAD min 1						
	100	200	300	400	500	700	800
103A - 103AR - 125A	25	17	14,5	13	12	11	7,5
104A - 104AR - 126A	43	25	20,5	17	15,5	13	12
105A - 105AR - 127A	68,5	43	39,5	36	33,5	28,5	26,5
106A - 106AR - 128A	86,5	84	72	57,5	51,5	41	36
107A - 107AR - 129A	156	120	96	72	60	48	
108A - 108AR - 130A	240	168	120	96	84	60	
109A - 109AR - 131A	300	192	144	120	96	72	
110A - 110AR - 132A	384	240	168	144	120	96	
111A - 111AR - 133A	432	264	192	156	132		
112A - 134A	456	300	228	174	144		
113A - 135A	504	336	264	216			
114A - 136A	720	480	336	264			

Para las juntas dobles utilizar el valor equivalente al 90% de los momentos de torsión mencionados

Momentos de torsión (en Nm) para juntas de cojinetes de aguja

Tipo	VELOCIDAD min 1					
	250	500	1000	2000	3000	4000
103V - 103VR - 125V				5,8		
104V - 104VR - 126V	22	17	14	11	10	9
105V - 105VR - 127V	34	29	24	22	20	18
106V - 106VR - 128V	65	55	45	40	37	32
107V - 107VR - 129V	75	61	50	45	40	36
108V - 108VR - 130V	140	120	100	80	70	65
109V - 109VR - 131V	162	132	108	88	77	71
110V - 110VR - 132V	200	170	130	110	90	85
111V - 111VR - 133V	300	270	230	190	160	140
112V - 134V	326	277	237	198	168	
113V - 135V	365	303	255	205	186	
114V - 136V	402	335	275	225	198	

Para las juntas dobles utilizar el valor equivalente al 90% de los momentos de torsión mencionados



Juntas universales

Momentos de torsión para juntas cardan



Momentos de torsión (en Nm) para juntas de acero inoxidable

VELOCIDAD min 1

Tipo	100	200	300	400	500	700	800
100X	3,6	3,3	2,8	2,5	2,3		
101X	4,4	4,4	3,5	3,2	2,9		
102X	8,6	6	5,3	4,6	4	3,4	3,1
103X	12,3	8,3	7	6,4	5,8	5,2	3,5
104X	21	12,6	10	8	7,3	6,3	5,8
105X	33	21,3	19,3	17,6	16,3	13,3	12,6
106X	45	42	35,3	29	25,3	20	17,3
107X	76	60	46,6	35,3	29,3	23,3	
108X	117	84	58,6	46,6	41,3	29,3	
109X	146	96	70	58,6	46,6	35,3	
110X	192	120	84	72	60	48	
111X	216	132	96	78	66		

Para las juntas dobles utilizar el valor equivalente al 90% de los momentos de torsión mencionados

Momentos de torsión (en Nm) para juntas de serie ligera

VELOCIDAD min 1

Tipo		100	200	300	400	500	700	800
	100AL	5.5	5	4.2	3.8	3.5		
	101AL	6.6	6.6	5.3	4.8	4.4		
	102AL	13	9	8	7	6	5.2	4.7
125AL	103AL	18.5	12.5	10.5	9.7	8.8	7.9	5.3
126AL	104AL	31.5	19	15	12	11	9.5	8.8
127AL	105AL	50	32	29	26.5	24.5	20	19
128AL	106AL	68	63	53	42	38	30	26
129AL	107AL	114	90	70	53	44	35	
130AL	108AL	176	126	88	70	62	44	
131AL	109AL	220	144	105	88	70	53	
132AL	110AL	288	180	126	108	90	72	
133AL	111AL	324	198	144	117	99		

Para las juntas dobles utilizar el valor equivalente al 90% de los momentos de torsión mencionados



Juntas universales

Montaje y mantenimiento de las juntas universales ROTAR

Las horquillas de las juntas deben estar en el mismo plano, de acuerdo al esquema siguiente. Un montaje incorrecto de las juntas producirá un movimiento no uniforme.

Correcto

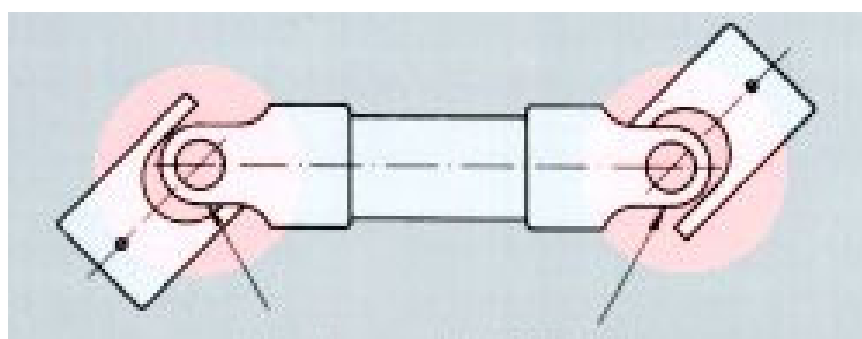

Incorrecto

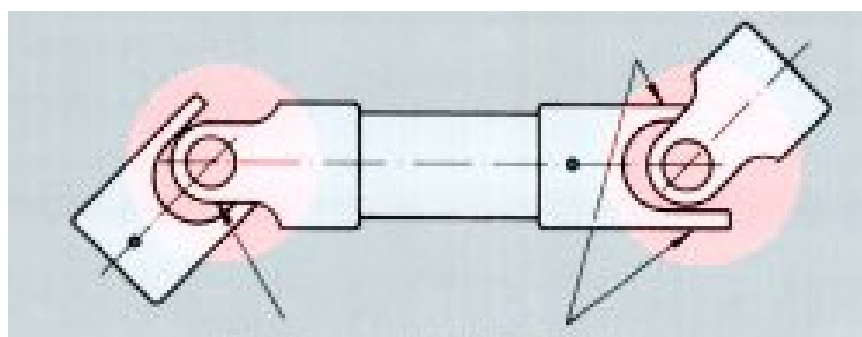

- Para montar las juntas con los árboles, se debe practicar el agujero a 90° sobre la línea mediana de las horquillas exteriores e interiores, que deben estar alineadas.
- El mantenimiento de las juntas universales se limita a una lubricación adecuada, que debe practicarse como mínimo una vez al mes.
- En los ambiente polvorientos es aconsejable proteger las juntas con unos casquetes de goma que, además de protegerlas de la contaminación ambiental, facilitan un proceso continuo de autolubricación, mediante la grasa que se acumula en su interior