

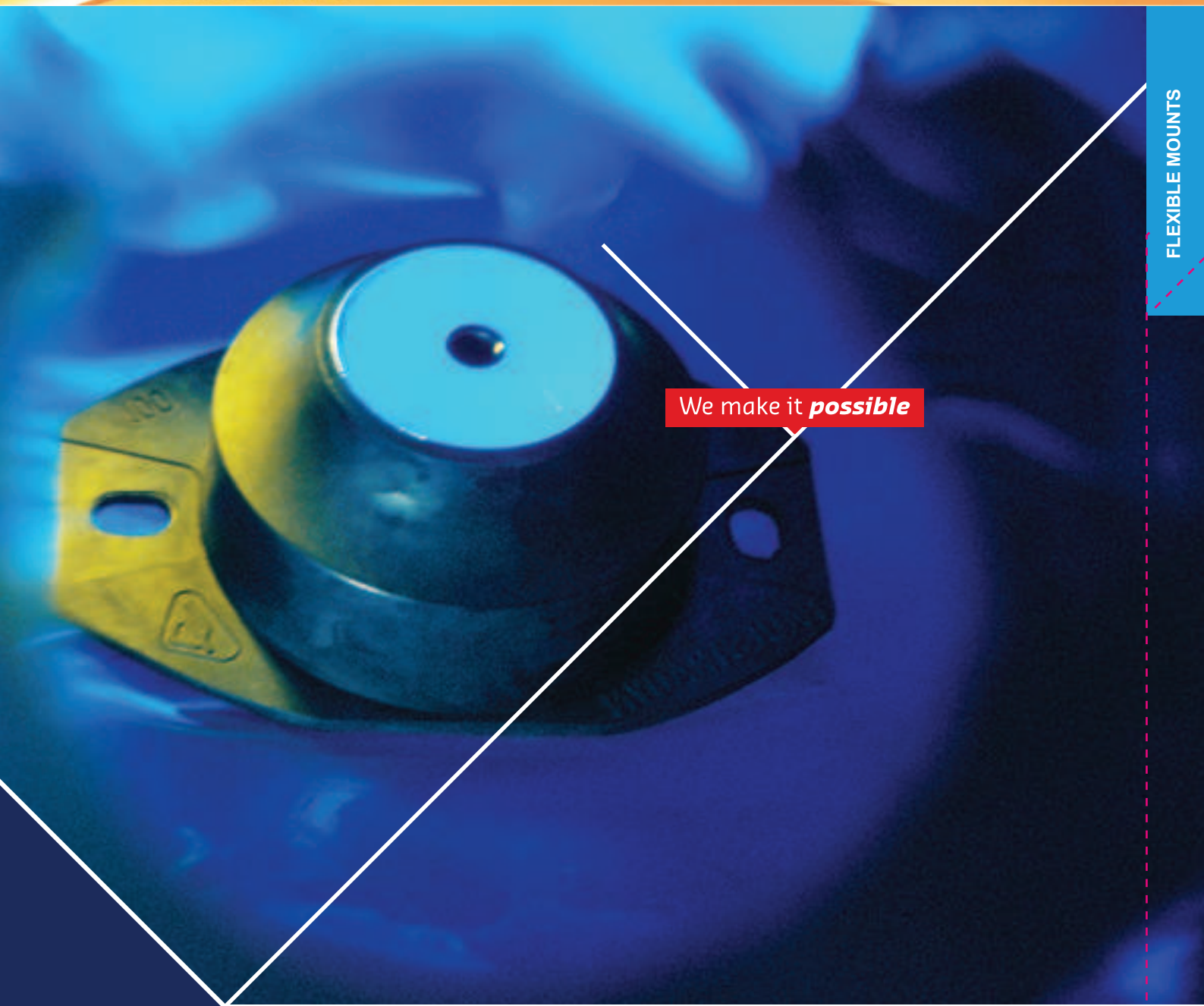

RODAVIGO, S.A.
RODAMIENTOS VIGO, S.A.

www.rodavigo.net

+34 986 288118
Servicio de Att. al Cliente



We make it **possible**

FLEXIBLE MOUNTS

FLEXIBLE MOUNTS

 | **HUTCHINSON**[®]
PAULSTRA



FLEXIBLE MOUNTS

CONTENT

	<i>page</i>		<i>page</i>
I - INTRODUCTION	33	DISK DRIVE SUSPENSIONS	118
II - DEFINITIONS		S.L.F® MOUNTS	119
II.1 Flexible Mounts	34	E1E931S / E1E4045	120
II.2 Flexible Mounting Systems	35	E1E11S**E* / E1E12S**E* / E1E13S**E*	122
III - FUNCTION OF FLEXIBLE MOUNTING SYSTEM		E1E11S**AL* / E1E12S**AL* / E1E13S**AL*	123
III.1 Static function	39	E1E21 / E1E22 / E1E23	124
III.2 Dynamic function	39	E1E31 / E1E32	125
III.3 Various types of flexible mounting systems	47	E1E41 / E1E42 / E1E43	126
IV - DESIGNING A FLEXIBLE MOUNTING SYSTEM		E1E941S	127
IV.1 Determining the centre of gravity	49	ARDAMP®	128
IV.2 Determining the load per mount	51	E1C 2321/E1T 2105	131
IV.3 Determining the deflection	53	BECA	134
IV.4 Design examples	54	POLYFLEX	137
V - INDUSTRIAL RANGE OF ELASTOMERIC		ISOFLEX®	138
MOUNTING APPLICATION GUIDE	58	ISODYNE®	140
RADIAFLEX®	60	SUSPENSION OF EQUIPMENT	
PAULSTRADYN®	64	IN MOBILE APPLICATIONS	142
EVIDGOM®	68	S.C.P MOUNTING	143
SANDWICH MOUNTS	71	BATRA® RING	144
STABIFLEX	74	OTHER MOUNTING SYSTEMS	146
PAULSTRAFLOAT	77	STRUCTURAL DAMPING SYSTEMS	150
CUPMOUNT	79	STRASONIC ACOUSTIC FOAM	151
S.C. MOUNTS	82	POLYURETHANE FOAM	
S.T.C.	86	-CORRUGATED, WITH SELF ADHESIVE LAYER	152
MOUNT 22000	88	-CORRUGATED AND HEAVY WEIGHT	154
TRIAXDYN	92	-HEAVY WEIGHT AND PU FILM	156
ENGINE MOUNTING SYSTEMS	94	FOAM	
STOPS	96	-MEETING WITH FIRE STANDARD M1	158
SUPPORTS AND BUMP STOPS	101	-MEETING WITH FIRE STANDARD M1/F3	160
NIVOFIX®	104	CELLULAR RUBBER	
MINIFIX®	106	-NBR BASED	162
TRAXIFLEX®	107	-EPDM BASED 15 mm	164
FLEX-LOC	109	-EPDM BASED 22.5 mm	166
RINGS AND BUSHINGS	111	VI - NAVY SHOCK MOUNTING SYSTEMS	
ELASTOMER MOULDED PARTS	114	NAVY SHOCK MOUNTING SYSTEMS	169
ELASTOMER PLATES E3PEPL	117	VIB LD 03 - DECOUPLING WASHERS	170
		LOW DEFLECTION MOUNTS	171
		VIBMAR	172
		VIB HD50	176
		VIB HD45	177
		VIB HD56	181
		GB 530 MOUNTS	184
		"X" TYPE FLEXIBLE MOUNTS	185
		VIB VHD75	
		- LOW LOADS	186
		- HIGH LOADS	189
		STRAFIX	190
		ACTIVE ISOLATION	192

See current price list for availability of items.

We reserve the right to modify the design and manufacture of the products and materials described in this catalogue.

The pictures of the products are supplied for information only.

The order comprises :

- the contract signed by both parties, or the purchase order and the acknowledgement of receipt,
- eventually, special or specific additional conditions, finalizing of exceptions and or additions
- general conditions of sale, available upon request are part of the order

I - INTRODUCTION

The reduction of noise and vibration has become very important :

- The need to improve operating conditions makes it essential.
- The increasing mechanisation of industrial and domestic equipment and appliances make it necessary.
- The lightness and increasing complexity of equipment demand it.

The following pages are dedicated to protection against vibration and shock. They offer design engineers the means to resolve isolation problems using elastomer alone or elastomer bonded to metal supports.

The first few pages start, therefore, with a summary of definitions and an explanation of the terminology used as well as the principal formula on which suspension calculations are based. The design of a flexible mounting system is a major undertaking and is the subject of a special section which gives the principles used to select a mounting system according to its size, characteristics, type and applications.

Warning : solving flexible mounting system problems very often requires the services of a specialist and we advise, very strongly, that if a simple solution cannot be found, then our Technical Services should be consulted.





II - DEFINITIONS

II.1 - Flexible mounts

II.1.1 - PROPERTIES

Flexible mounts are components which exhibit both flexibility and damping, at the same time and to varying degrees.

- **Flexibility**

- Flexibility is the ability of the mount to deform and recover, with an amplitude approximately proportional to the load.

- **Damping**

Damping is a braking force the most important effect of which is the reduction of oscillations.

There are essentially two types of damping :

- Constant friction (dry friction) which, for a given setting, provides a constant braking force independent of the movement. For there to be movement, it is, therefore, necessary to apply a force at least as great as the frictional force.

- Viscous damping (such as that provided by hydraulic dampers) which provides a braking force proportional to the instantaneous velocity of the suspended part relative to the fixed part. Viscous damping is, therefore, essentially dynamic: it does not affect the position of static equilibrium.

II.1.2 - ENVIRONMENTAL CONDITIONS

Most of the standard mounts are made of natural rubber which has been chosen because of its good dynamic properties. Under normal operating conditions, these rubber compounds guarantee stability over long periods and, in particular, limited creep.

The following operating conditions are considered abnormal :

- temperatures greater than 70°C,
- prolonged contact with corrosive liquids,
- prolonged contact with acids or alkalis,
- aggressive environment (oils, fuels),
- corrosive gases (ozone, chlorine...).

Using a mount unintentionally under such conditions can lead to premature ageing, degradation or even destruction of the rubber. An abnormally aggressive environment can, in particular, increase the deformation of the mounting (creep).

PAULSTRA flexible mounts may be made using various special compounds that are highly resistant and able to withstand the abnormal conditions described above.

Our Technical Services are at your disposal to reply to any queries about the properties of particular compounds.

II.1.3 - ELASTOMERIC FLEXIBLE MOUNTS

Mounts using natural or synthetic elastomers always provide a combination of pure elasticity and viscous damping. Although commonly used, the term "shock absorbers" is completely incorrect. The two characteristics, flexibility and damping, are, in fact, essentially different : a rubber mounting may be compared to a car suspension where the two functions are provided by different components working in parallel :

- true elastic suspension provided by springs,
- damping provided by hydraulic damping (shock absorbers).

A flexible mounting using rubber = a spring + a damper.



II.1.4 - CHARACTERISTICS OF ELASTOMERIC FLEXIBLE MOUNTS

• Elastic properties

These are the parameters which define the ability of the mounting to be deformed in various directions.

- **The linear stiffness** K_x , along the axis G_x is the ratio of the force to the corresponding displacement along this axis. The linear stiffness is expressed by daN/mm.

The linear stiffness (K_y, K_z) for the other axes (G_y, G_z) are defined in the same way.

- **The torsional stiffness** (C_x, C_y, C_z) about the three axes (G_x, G_y, G_z) is the ratio of the torque to the angular displacement about the axis.

The torsional stiffness is expressed in m.daN/rad.

These six parameters, which are not independent of each other for a given mount (the interdependence changes with the shape and structure of the mounting) are proportional to the Young's modulus of the elastomer used in the mounting.

Using these six values, it is possible to calculate the stiffness along or about any arbitrary axis.

• Damping properties

The most useful parameter is the "intrinsic damping factor" of the elastomer used. This will be defined for a suspension (§ II.2.2). The intrinsic damping factor of a mount is the same as that of the suspension.

II.2 - Flexible mounting systems

A machine is suspended elastically by placing flexible mounts between the machine and its seatings (floor, slab, chassis, etc.). The type of mounts, its number, distribution, positioning and individual characteristics, depend on the overall characteristics required by the suspension to give the desired result.

The most common problems are those where vibration determines the essential characteristics of the suspension. It is necessary, therefore, to start with a presentation of the terminology and a review of the most important definitions and principles.

II.2.1 - VIBRATION THEORY CONCEPTS

A machine, suspended elastically, vibrates when it is subject to periodic alternate influences which produce oscillations of greater or lesser amplitude.

There are two main modes of vibration :

- Natural or free vibration, which is the vibration of the machine that occurs when it is released after having been displaced from its position of equilibrium,
- Forced vibration, which is imposed on the machine, either by its own operation, or by influences from its surrounding.

• Degrees of freedom

The number of degrees of freedom is the number of independent parameters which determine the position of the machine at any given time.

Degrees of freedom of movement :

- Linear movement parallel to a given axis (the independent parameter is the displacement along the axis),
- Rotation about a given axis (the independent parameter is the angle of rotation about the axis).

• Vibrations with only one degree of freedom

The following discussion applies to vibrations with only one degree of freedom : a linear vibration parallel to a fixed axis.

• Periodic vibration :

- Frequency : Number of complete cycles in a unit of time.

N = Number of cycles per minute.

n = Number of cycles per second (Hertz).

- Period : Duration of one cycle.

$$T = \frac{1}{n} \text{ in second.}$$

- Pulsation : $\omega = 2\pi n = \frac{2\pi}{T}$ in radians per second

- Maximum amplitude : The maximum offset from the equilibrium position for each cycle. For a forced vibration under constant conditions, the amplitude remains constant.

- Sinusoidal vibration $x = A \sin \omega t$ (shape 1)

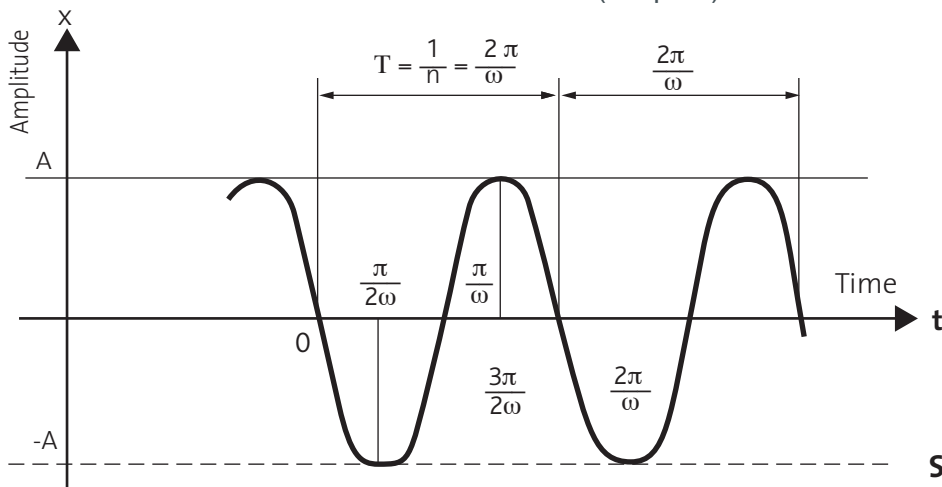

Shape 1

- Frequency $n = \frac{1}{T} = \frac{\omega}{2\pi}$

- Amplitude A
- Maximum velocity $V = A\omega$
- Maximum acceleration $\Gamma = -A\omega^2$
- Instantaneous amplitude $x = A \sin \omega t$
- Instantaneous velocity $v = A\omega \cos \omega t$
- Instantaneous acceleration $Y = -A\omega^2 \sin \omega t$

High frequency vibrations (high ω) may, therefore, produce very high accelerations even at low amplitudes.

II.2.2 - CHARACTERISTICS OF FLEXIBLE MOUNTING SYSTEMS

• **Elastic properties**

These are the parameters which define the freedom of a machine to move with respect to its seating. The movements are, usually, referred to an axis system (G_x, G_y, G_z).

In the example in shape 2 :

- The origin of the axis system is at the equilibrium position of the machine's centre of gravity.
- The axes are parallel to the axes of symmetry of the machine.

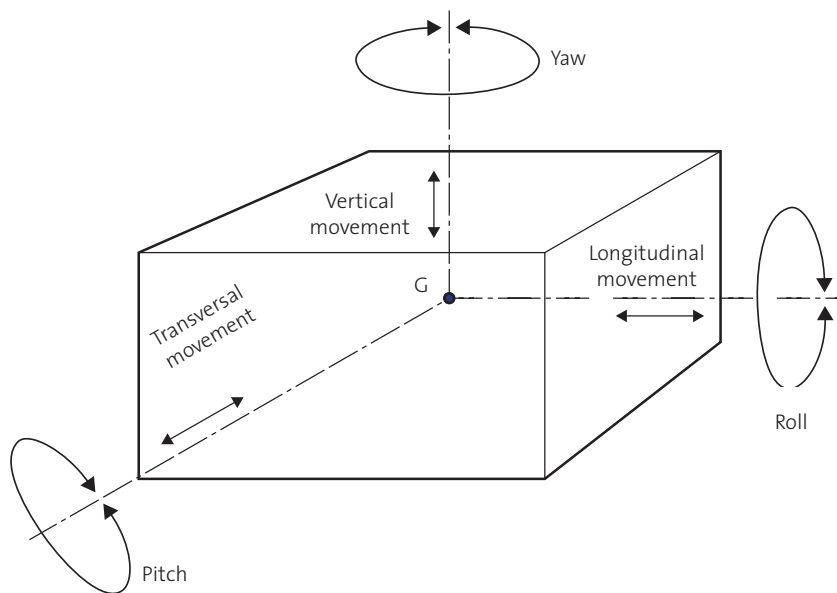

Shape 2

As for mounts, the stiffness of a suspension is defined for displacements with only one degree of freedom relative to a fixed set of axes.



- Linear stiffness :

K_x along G_x = longitudinal movement

K_y along G_y = transverse movement

K_z along G_z = vertical movement

For each axis, the linear stiffness is the sum of the linear stiffness of all the mounts.

$$K_x = \Sigma K_x \qquad K_y = \Sigma K_y \qquad K_z = \Sigma K_z$$

- Torsional stiffness :

C_x about G_x = roll

C_y about G_y = pitch

C_z about G_z = yaw

The torsional stiffness of the suspension depends on :

- The individual stiffness of the mounts,
- The position and orientation of the mounts with respect to the centre of gravity G of the machine.

• Damping properties

Elastomers exhibit viscous damping, the braking force applied to an elastic suspension is $R \times V$, where :

R is the resistance,

V is the relative velocity of the suspended machine at time t.

If, starting with an undamped suspension, the damping is progressively increased (with all other factors remaining constant) the amplitude of the free oscillations, starting from a given initial offset, die away more and more quickly.

The value of damping for which the return to the equilibrium position is asymptotic (without oscillation) is called the “critical damping” and is denoted by a resistance R_c .

The damping factor ϵ is defined for a resistance R :

$$\epsilon = \frac{R}{R_c} \quad (\epsilon = 1 \text{ for critical damping})$$

When suspension is subjected to forced vibrations at a frequency ω , it has been shown that, for natural elastomers, the product $\epsilon\omega$ remains reasonably constant. This is equally true at the resonant frequency (see below).

$$\epsilon \omega = \epsilon_0 \omega_0 \text{ constant } (\omega_0 \text{ is the resonant frequency}).$$

ϵ_0 being the damping factor at the resonance frequency.

It can be shown that ϵ_0 is an intrinsic property of the elastomer used.

ϵ_0 = intrinsic damping factor.

ϵ_0 of a suspension = ϵ_0 of each mounting (if all mountings use the same elastomer).

• Electrical characteristics

Elastomers have an electrical resistance which varies according to their composition, hardness. As a guide, the following values have been measured for our standard elastomers.

Natural Rubber	hardness 45	10^{13}	Ohm x cm^2/cm
	hardness 60	10^6	Ohm x cm^2/cm
	hardness 75	10^4	Ohm x cm^2/cm

We have also developed special elastomers which can have a dielectric strength greater than 2,000 Volts for 1 minute.

• **Creep characteristics**

The following formula, which is derived from measurements on samples, gives an estimate of the creep for a load which compresses a Radiaflex mount by 10% of its height at a temperature of 30°C. The creep for an actual mounting also depends equally on its shape.

Static deflection at time t = initial static deflection x (1 + C_m x f(t))
where f(t) is the value of the creep from the graph below:

Creep f(t) in compression relative to the initial static deflection.

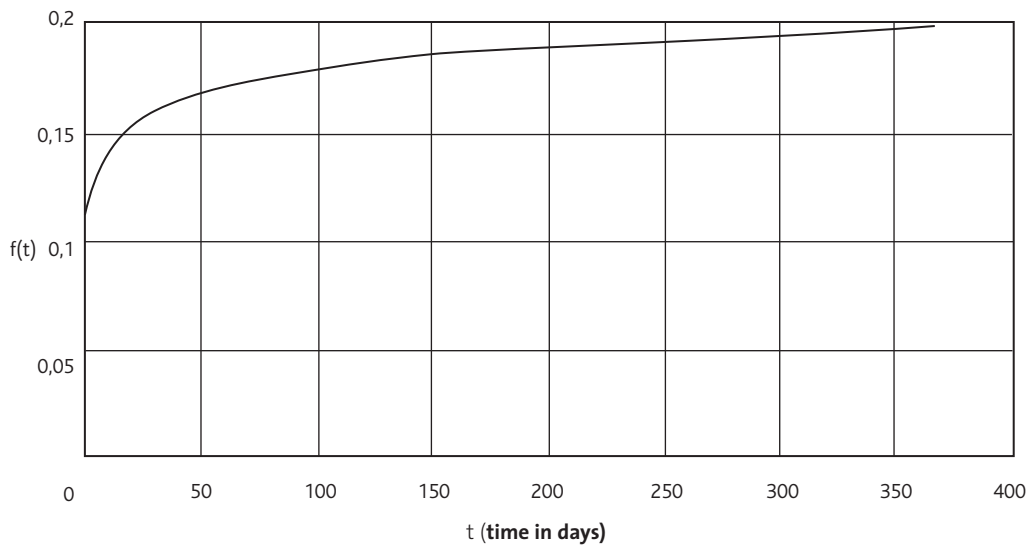

and C_m is a correction coefficient taken from the table below according to the sample material :

Material	Hardness 45	Hardness 60	Hardness 75
Standard natural rubber	1.0	1.6	1.7
Polychloroprene	1.1	1.6	1.6

Note :

These values are given as a guide only. Consult us for use under other conditions (temperature, complex profiles or other elastomers).

Mounting :

For applications where alignment is important, to overcome the problems of initial creep of the elastomer mounts, adjustment to align the axes of shafts should be made at least two days after the machine has been mounted.

III - FUNCTION OF A FLEXIBLE MOUNTING SYSTEM

III.1 - Static function

An elastic suspension allows the static load to be more evenly distributed.

If a machine rests on more than three points using “rigid” mountings, it is impossible to predict the load on each mounting point and the machine could be unevenly stressed.

With elastic mounts having a known stiffness, it is possible to determine (by calculation, or direct measurement) the deflection in each mounting and thus deduce the loading and correct any imbalance.

An elastic suspension accomodates minor differences in the distance between mounts. However many mountings there are, in order to avoid excessive local stresses, a rigid assembly requires very close tolerances on the distance between mountings and of the mating surfaces of the machine and its seatings.

To avoid prohibitively close manufacturing tolerances, “play” is allowed in the mount which gives rise to the well known problems of wear and noise due to loose fixings.

Flexible mounts allow larger manufacturing tolerances without large variation in forces.

An elastic suspension can also absorb small movements due to, for example, the expansion or the deformation of chassis, bodyshells, girders, etc.

III.2 - Dynamic function

This is the primary function of elastic suspensions where there is vibration or shock. The calculations presented here assume that the linear stiffness of the mounts remains constant. This is true for elastomeric mountings in normal conditions of use (mechanical vibration, normal temperature).

III.2.1 - VIBRATIONS WITH ONLY ONE DEGREE OF FREEDOM

The action of a flexible mounting system is very complex. To present the principles, we will study a simple idealised case (shape 3).

Taking the case of a machine of mass M constrained so that it can only move in a direction parallel to the vertical axis Gz .

It is attached to its seatings by a flexible mount S with a stiffness K along the axis Gz .

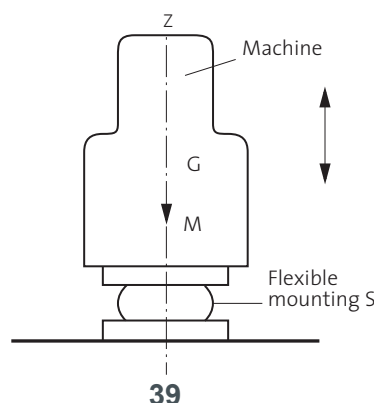

Shape 3

• **Free oscillation (natural frequency)**

a) Undamped (entirely theoretical)

The machine, having been displaced from its position of equilibrium by a distance A, oscillates sinusoidally.

The equation of motion is : $z = A \sin \omega_0 t$

The natural pulsation is $\omega_0 = \sqrt{\frac{K}{M}}$ Proper frequency $F_p = \frac{\omega_0}{2\pi}$

The oscillation continues indefinitely with an amplitude A (as shown in shape 1 with ω replaced by ω_0).

b) Damped

In this case, the machine oscillates about its position of equilibrium with a damped sinusoidal motion (see shape 4). The equation of motion is :

$$z = A.e^{-\varepsilon'_0 \omega'_0 t} . \sin \omega'_0 t$$

The natural pulsation is :

$$\omega_0 = \sqrt{\frac{K}{M} (1 - \varepsilon_0'^2)} = \omega_0 \sqrt{1 - \varepsilon_0'^2}$$

ε'_0 is the damping factor at the frequency ω'_0 .

As ε'_0 is very close to ε_0 , the natural frequency may, therefore, be written as :

$$\omega'_0 \approx \omega_0 \sqrt{1 - \varepsilon_0^2}$$

For natural rubber, ε_0 is small by comparison with 1 (from 0.02 to 0.1).

ω'_0 is, therefore, very close to ω_0 .

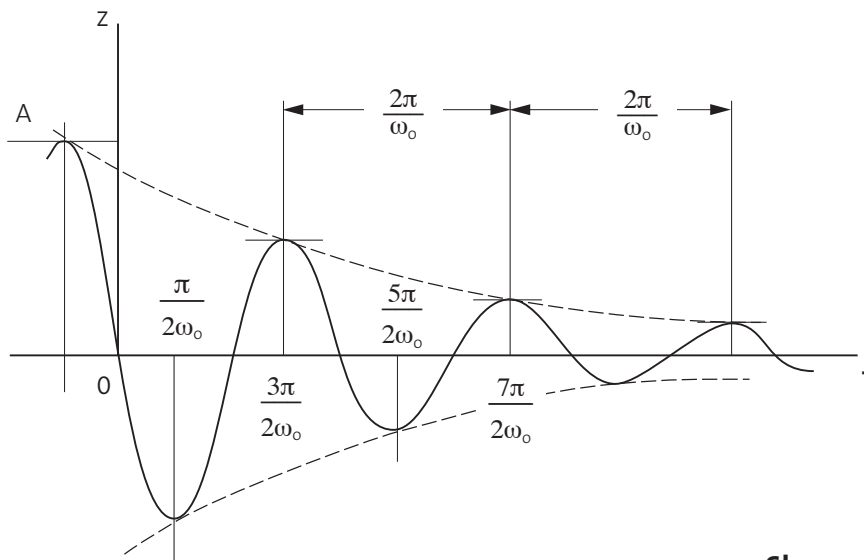

Shape 4

• **Forced vibration**

If the machine is now subject to forced vertical vibration induced by a sinusoidal force of frequency ω .

The inducing force is $F = FM \sin \omega t$.

- For a rigid suspension : the inducing force is transmitted directly to the structure the machine is mounted on.

- For an elastic suspension with a natural frequency ω_0 or proper frequency $F_p = \frac{\omega_0}{2\pi}$ and damping factor ϵ_0 :

When the inducing force is applied, an oscillation is induced at the natural frequency ω_0 which dies away rapidly so that, after a short period, only the steady state forced vibration at frequency ω remains which transmits a sinusoidal force to the surrounding structure.

The force transmitted is: $F' = F'M \sin \omega t$.

A transmission coefficient λ is defined as the ratio between the amplitude of the force transmitted $F'M$ to the amplitude of the inducing force FM (or, if preferred, the force that would be transmitted if the suspension was not elastic).

For a mounting system using elastomeric mounts, this coefficient is :

$$\lambda = \frac{F'M}{FM} = \sqrt{\frac{1 + 4 \epsilon_0^2}{\left(1 - \frac{\omega^2}{\omega_0^2}\right)^2 + 4 \epsilon_0^2}}$$

To summarize :

	Inducing force	Transmitted force	Transmission coefficient
Rigid system	$F = FM \sin \omega t$	$F = FM \sin \omega t$	$\lambda = 1$
Flexible system (ω_0, ϵ_0)	$F = FM \sin \omega t$	$F' = F'M \sin \omega t$	$\lambda = \frac{F'M}{FM} = \sqrt{\frac{1 + 4 \epsilon_0^2}{\left(1 - \frac{\omega^2}{\omega_0^2}\right)^2 + 4 \epsilon_0^2}}$

The variations of the transmission, coefficient λ , as a function of $\frac{\omega}{\omega_0}$ for various values of ϵ_0 are shown in shape 5 (page 12).

Attenuation

For rubber mountings, the term $4 \epsilon_0^2$ is much smaller than 1. The attenuation in % is $1 - \lambda$:

$$E \% = 100 \frac{\left(\frac{\omega}{\omega_0}\right)^2 - 2}{\left(\frac{\omega}{\omega_0}\right)^2 - 1} \quad \text{ou} \quad 100 \left(1 - \frac{1}{\left(\frac{\omega}{\omega_0}\right)^2 - 1}\right)$$

For a given induced frequency ω the attenuation depends on the natural frequency of the suspension.

For a particular direction, the relationship between the natural frequency, the suspension's sub-tangent and the induced frequency are plotted on the chart shape 6.

For a particular induced frequency (for example 1500 rpm) it is possible to find the sub-tangent which will provide an acceptable attenuation. In general, an attenuation greater than 50% is required. For this example, the chart indicates that an attenuation of 80% will be achieved for a natural frequency of 10 Hz (see section IV.3.1).

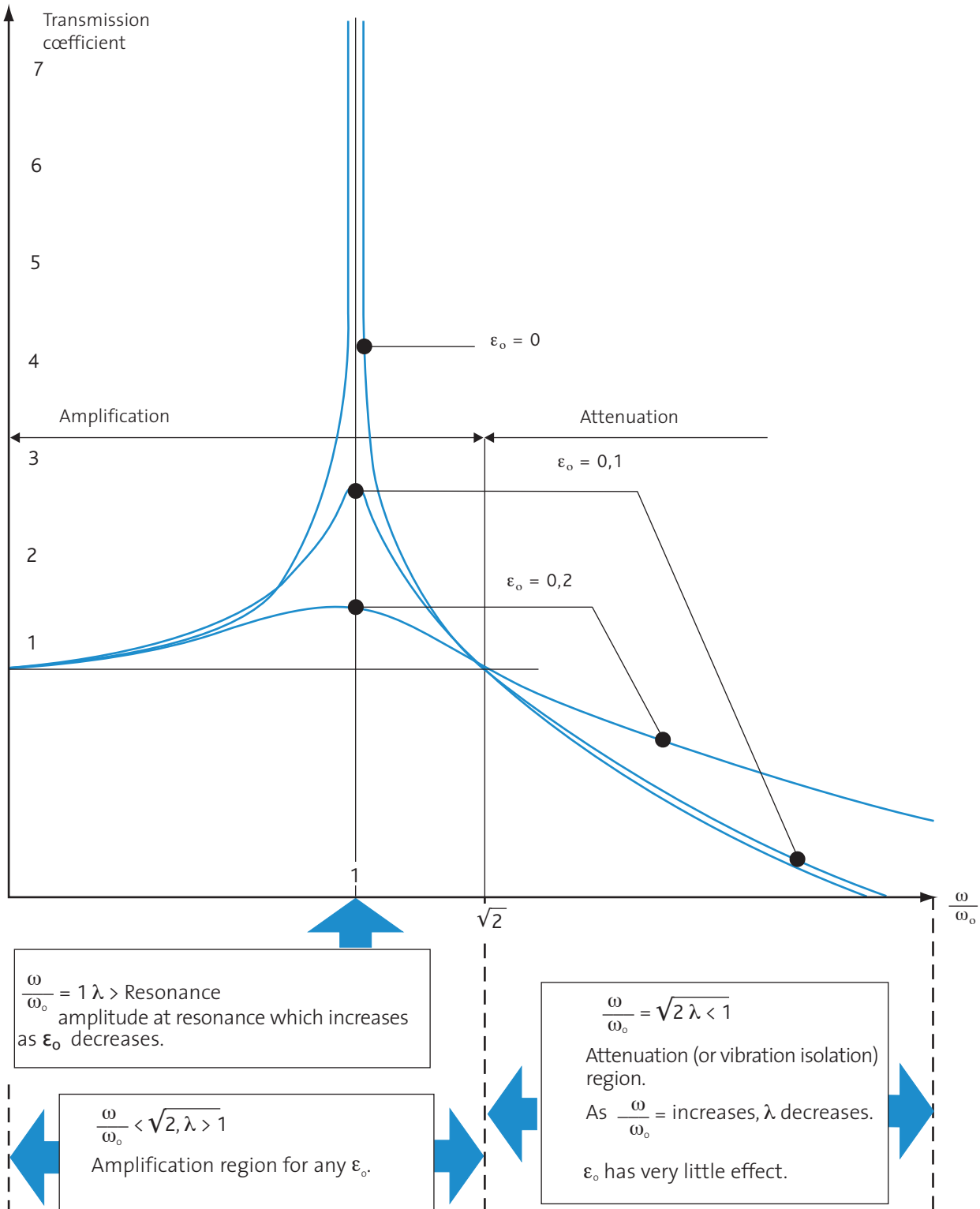

Shape 5

An efficient mounting system use :

a high value of $\frac{\omega}{\omega_0}$ → low values ω_0 → low values λ

a moderate ϵ_0 → - limited amplification in the resonant region.
- minor effect in the attenuation region.



Attenuation as a function of natural frequency and frequency of excitation. (A theoretical graph for a mounting system without damping)

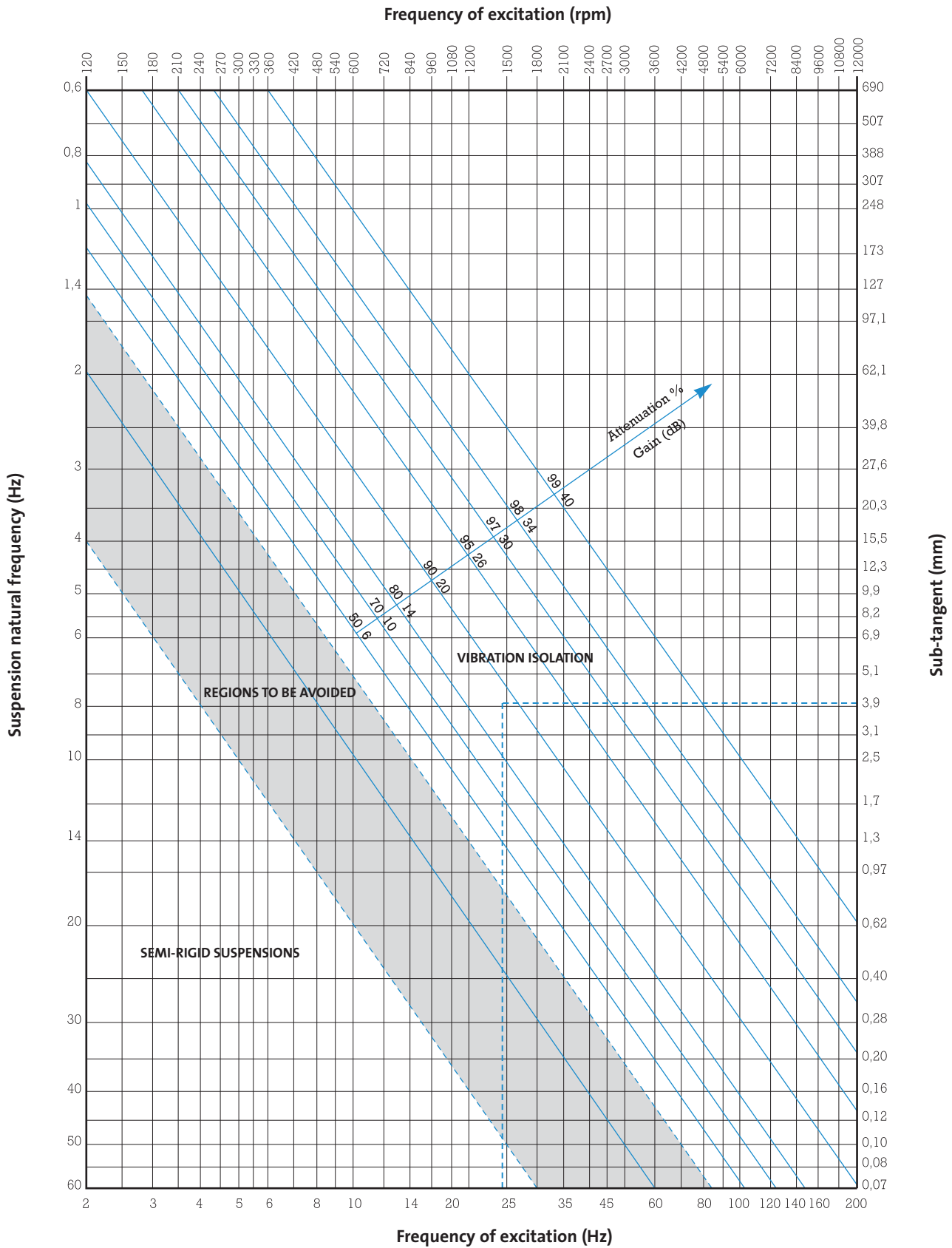

Shape 6

• **Practical considerations**

a - Variable speed machines

In practice, there may not be a single, well defined value for ω , as machines may have a variable speed (variable ω).

In these cases, the vibration isolation should be determined for the lowest speed.

b - Passing through resonance

All machines must start and stop.

Starting from rest to reach the speed ω (in the vibration isolation region), it is necessary to pass through the resonant region.

It is necessary to ensure :

- that the passage through resonance is as quick as possible;
- that the suspension is sufficiently well damped so that the maximum force transmitted presents no risk for the machine, the suspension or the seating.

c - Elastomeric suspensions

For the elastomers currently used in flexible mounting systems, the intrinsic damping factor ϵ_0 lies between 0.02 and 0.1 (it can be as high as 0.2 with synthetics such as butyl rubber).

- In the vibration isolation region, the formula for the transmission coefficient is simplified as, for the values of ϵ_0 for natural rubber, the term $4\epsilon_0^2$ is negligible by comparison with 1.

$$\lambda = \frac{1}{\frac{\omega^2}{\omega_0^2} - 1} \quad \text{For } \epsilon_0 \text{ between } 0.02 \text{ and } 0.1$$

- At resonance $\lambda_r = \frac{1}{2 \epsilon_0} \qquad \lambda = \frac{1}{2 \epsilon}$

For natural rubber, therefore, the amplification at resonance is between :

$$\frac{1}{2 \times 0,1} = 5 \quad \text{and} \quad \frac{1}{2 \times 0,02} = 25$$

a) Noise and vibration

Noise is a random vibration. It is formed by the combination of a number of uncorrelated fundamental frequencies. Noise gives rise to **sound**.

Airborne noise is usually treated separately from structure borne noise.

Sound is associated with the disturbance of a medium (solid, liquid or gaseous). This disturbance is in the form of a vibration of the molecules of the medium about their position of equilibrium.

b) Improving acoustics

An elastic suspension affects only structure borne noise.

This is a vibration of the building structure and a flexible mounting system breaks the transmission close to the source. The resilience of the attachment reduces the forces transmitted to the base and its vibrational energy.

Transmission from one room to another

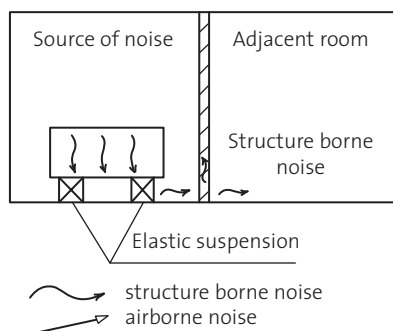

Example: Workshop with guillotine (shock and noise)

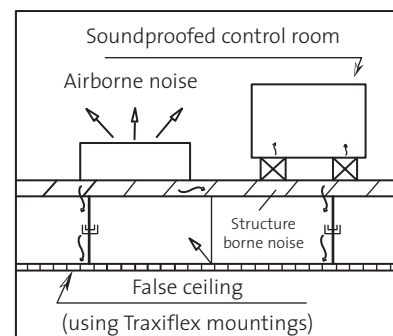

As the radiation efficiency is unchanged, the improvement in terms of radiated power (acoustic) is the same as the improvement in terms of the force transmitted. The curve giving the vibrational attenuation in % may be translated into decibels.

Attenuation in dB is $20 \log \frac{100}{100 - E}$ where E is the attenuation in % (structure borne, not airborne noise).

The suspension of the machinery allows the **adjacent room** to be sound insulated and to be made more quiet. The rigidity of the base supporting the suspended mass must always be taken into account. As a rule, it is considered that unless the mountings are ten times more flexible than the base the choice of suspension must be re-considered.

PAULSTRA mountings may be characterised at high frequencies.

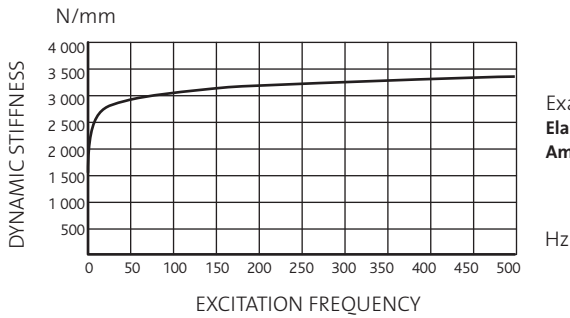

Example of measurements made on a special Radiaflex mounting.
Elastomer: polychloroprene hardness 47
Amplitude ± 0.01 mm about the position under static load

III.2.3 - SHOCK

• The nature of shock

For a given period, the equipment is subjected to a brief, impulsory excitation. It is the most severe type of excitation that it may encounter during its lifetime.

During the period that the excitation is applied, the speed of the equipment will vary : it is subject to acceleration and, therefore, to a force.

A system that reacts slowly will not be subject to the same shock as a system that reacts quickly. It is necessary to compare the length of period that the stimulus is applied, against the natural frequency of the equipment.

• Types of shock

In practice, there are two types of problems.

- The equipment is subjected to shocks which are well defined by experiments, but are very complex and not reproducible under laboratory conditions. It is, therefore, necessary to define an equivalent shock.
- The equipment must resist shocks which are arbitrarily defined (e.g. meeting standards). A shock is defined by an excitation which varies with time: the acceleration, the speed or the displacement of the point where the excitation is applied. In some cases, it is better to define the shock as the energy transferred to the equipment (e.g. vehicle impact).

• Protection against shock

There are two principal cases to be considered :

a) Limitation of the force transmitted to the equipment :

This case often appears in the following form :

The equipment, moving at a known speed, meets an obstacle. The force that it can withstand without damage is limited to a known value.

A system of rubber parts, which could be the flexible mounting system of the equipment, is placed between the equipment and the obstacle.

These parts provide a constant stiffness K_z in the direction of the shock. If there is energy W to be absorbed in the absence of damping:

$$W = \frac{1}{2} K_z Z^2 \quad \text{The maximum force } F_M = K_z Z = \frac{2W}{Z} \quad \text{The maximum force is inversely proportional to the travel.}$$

$$\text{The travel } Z = \sqrt{\frac{2W}{K_z}} \quad \text{The travel is inversely proportional to the square root of the stiffness.}$$

Remarque : Some systems do not have a constant stiffness, but a stiffness which increases rapidly (e.g. compression systems). It is clear that if the energy W is not absorbed before the stiffness increases, the maximum force will be much higher than predicted by this formula.

b) Limiting the acceleration of particular parts of the equipment

In this case the shock must be described in terms of its potential to destroy. The efficiency of the protection system is measured by its ability to reduce this potential. A shock to the equipment can damage a component part if this part is induced to vibrate at an amplitude which is incompatible with its mechanical characteristics thus causing it to break.

A shock can be characterised by its action on a whole series of components.

For the same shock, each component has its own specific response, which differs from one component to the next.

The shock spectrum is the graphical representation of the ratio of amplitude of vibration (Γ) of the components to the amplitude of the shock (Γ_0) as function of the ratio of the duration of the shock τ to the natural frequency T of the elements.

This is not a representation of the amplitude as a function of time, neither of the excitation nor of the effect, but a convenient representation of the destructive power of a shock.

The representation is not reversible.

- It is not possible to recover the form of the shock from the spectrum.
- Two different shocks may well produce the same spectrum.

Take, for example, the case of shock with a semi sinusoidal acceleration.

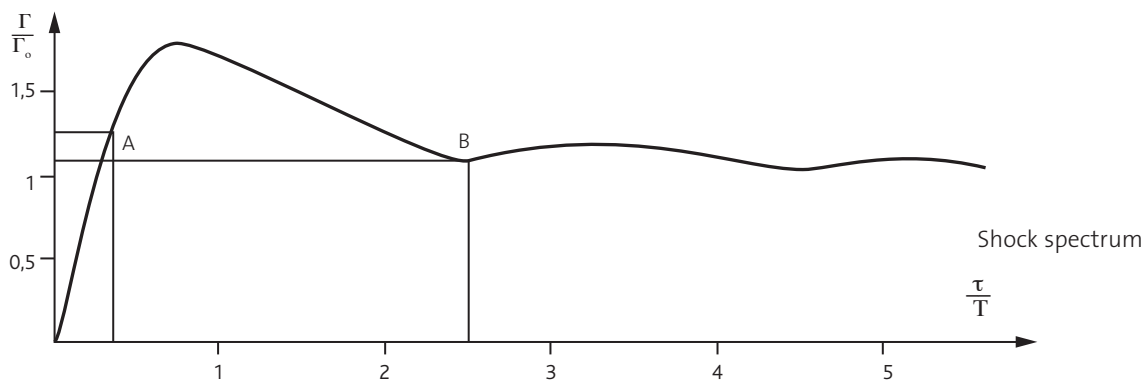

A piece of equipment must withstand a shock of $I_0 = 400 \text{ m/s}^2$ for a period $t = 8.75 \times 10^{-3} \text{ s}$.

	Component A of the equipment	Component B of the equipment
Natural frequency mass	40 Hz 10 kg	286 Hz 1 kg
$\frac{\tau}{T}$	$8,75 \cdot 10^{-3} \times 40 = 0,35$	$8,75 \cdot 10^{-3} \times 286 = 2,5$
$\frac{\Gamma}{\Gamma_0}$	1,25	1,1
Load on mounting points	$400 \times 1,25 \times 10 = 5000 \text{ N}$	$400 \times 1,1 \times 1 = 440 \text{ N}$

Study of the spectrum shows that the performance of a mounting system is acceptable when it is possible to obtain a natural frequency T such as:

$$\frac{\tau}{T} < \text{in which case the ratio } \frac{\Gamma}{\Gamma_0} \text{ is less than 1 and the component is protected.}$$

If it is not possible, it is better to set up the flexible mounting system to avoid the region of significant amplification for:

$$\frac{\tau}{T} \text{ between } 0.25 \text{ and } 2.5$$

This simple case shows the role of a flexible mounting system and the importance of knowing the details (shock spectrum, amplitude as a function of time) and, above all, the duration of the shock.

• The role of damping

Damping can be useful in reducing rebounds and the amplitude of successive cycles of oscillation. It is, however, important not to use just any type of damping as some can give rise to unfortunate reactions. Elastomers provide a compromise which allow the provision a high level of protection.



- Important note
Two points must always be borne in mind when designing equipment:
- Firstly, that a high level of protection requires great flexibility which requires considerable clearance between the equipment and its surrounding.
- Secondly, that the equipment will oscillate and room must be allowed for the rebound in case of shock. Travel limiters must be positioned so that they do not impede the operation of the flexible mounting system during the shocks allowed for in the design.

A flexible mounting system using rubber protects against shock by reducing the travel and maximum force. It is necessary to allow enough clearance for the rebound.

III.2.4 - GENERAL CASE

Theoretical study above is based on a very simple case:

movement with only one degree of freedom (vertical) with only one excitation (also vertical) aligned with both the centre of gravity of the suspended machine and the centre of elasticity of the mounting system.

In general, things are not so simple. The machine can move in any of the degrees of freedom (rotation or linear movement). In theory, there are as many **natural frequencies** as there are degrees of freedom.

These natural frequencies are not independent but are “coupled”. If one of these is excited in one degree of freedom, it can, as a result of the **coupling**, give rise to vibrations at the same frequency in other degrees of freedom.

To analyse the whole behaviour, the **stiffness** in all directions needs to be taken into account and not just the mass of the suspended body but also the **moments of inertia** so that rotational behaviour can be evaluated.

In addition there may be not one but several forced vibrations, with variable frequencies applied to several different points, in various directions or about various axes.

Even general cases can be very complex however symmetrical structures and mounting arrangements allow the use of the single degree of freedom analysis shown above. In other cases only an in-depth study allows an effective solution to be found. Our Technical Services are there to help you to define it.

III.3 - Various types of flexible mounting systems

III.3.1 - ACTIVE ISOLATION SYSTEM

This is a flexible mounting system designed to prevent a machine from transmitting its vibrations to its seating or foundation.

This is the theoretical problem (with one degree of freedom which was treated, by attenuating the vibration, in the preceding pages.

The vibration isolation does not stop the machine from vibrating, but it reduces the transmission of these vibrations.

By comparison with a rigid suspension (which transmits the vibrations) the amplitude of the machine's vibrations may be greater. The machine is, to an extent, freed from its fixed seating. This is the case for the automobile “floating engine” which, mounted on a flexible mounting system, no longer transmits its vibrations to the bodywork and the passengers due to increased mobility under the bonnet (hood).

If excessive movement cannot be tolerated, the only way to reduce it, without reducing the efficiency of the flexible mounting system, is to increase the suspended mass (ballasting). For a given excitation, the amplitude is inversely proportional to the mass.

This is necessary for certain machines which produce particularly severe vibration: slow single cylinder compressors, centrifuges, power hammers etc.

These machines, are therefore, rigidly fixed to a chassis or heavy slabs and the whole assembly is suspended.

Increasing the suspended mass allows good vibration isolation with limited vibration of the suspended assembly.

It is worthwhile suspending complete assemblies rather than individual machines: generating sets, motor/compressor units, motor/pump units.

III.3.2 - PASSIVE ISOLATION SYSTEM

This is a flexible mounting system designed to protect a non-vibrating machine from the vibrations of its surroundings.

The design of a flexible mounting system for attenuating vibration, as defined above, is still valid. With the correct flexible mounting system, the acceleration transmitted to the machine is very small and as it is not subject to any other excitation it remains almost stationary.

The vibration of the supporting structure is almost entirely absorbed by the flexible mounts.

III.3.3 - SEMI-RIGID MOUNTING SYSTEM

This is a suspension where there is no vibration isolation for a given frequency ω

$$\left(\frac{\omega}{\omega_0} < \sqrt{2} \right)$$

As shown above, such a mounting system should be of no interest as it leads to an amplification of the vibration, not an attenuation. In practice, it can, however, give reasonable performance in the following two cases.

- **Coupling**

In practice, there is not just one movement. For a mounting system, several movements are possible. In fact, as we have seen (shape 2), a machine may have six degrees of freedom. A proper study of a mounts system will take into account the type of excitation acting on the machine and try to arrange that it does not vibrate in all directions. However, because of constraints on mounting points, the mounts may not always be put in ideal positions: if the machine is subject to an excitation in one direction, it may, therefore, move in several directions, e.g. two. These two movements are said to be "coupled".

The natural frequencies in each direction are not identical. The coupling between the two movements has the effect of lowering the lower natural frequency and raising the higher. Instead of having one maximum (shape 5), the response curve has two. It is essential the excitation does not fall on one or the other. As it may demand an impossibly high flexibility, it is not always possible to make the coupled natural frequencies sufficiently low to put the frequency of the excitation in the vibration isolation region. On the other hand, if the two natural frequencies are placed on either side of the frequency of the excitation, a modest attenuation may be obtained.

- **Harmonics**

A vibration of frequency ω is rarely "pure". Frequently it also includes "harmonics"; i.e. vibrations at related frequencies 2ω , 3ω ... Even if it is not possible to provide vibrational isolation of the fundamental ω , it may be possible to attenuate the harmonics. This may be more important as the low frequencies are often inaudible and, in addition, correspond to very small mechanical accelerations whereas the higher frequencies are a source of noise which can be eliminated by an appropriate vibration isolator.

III. 3.4 - EXTERNAL CONNECTIONS

So far, it has been assumed that the machine is only connected to its surrounding by its flexible mounting system.

In practice, there will be other connections, such as:

- Pipework (inlet, exhaust, cooling).
- Electric cables, remote controls...

It is necessary to ensure, or arrange, that these external connections are sufficiently flexible with respect to the relative movements.

This precaution will avoid:

- Damage to pipework.
- Reduced vibration isolation by introducing additional rigidity.
- Direct transmission, via these connections, of the vibrations which have been suppressed elsewhere.

As the flexible mounts attenuate the transmission of the vibrations the machine is free to move, be sure to leave enough clearance in all directions to allow freedom of movement.

IV - DESIGNING A FLEXIBLE MOUNTING SYSTEM

When designing a flexible mounting system, it is essential to know, precisely the basic characteristics of the machine to be suspended.

It is extremely useful to have a drawing (even if it is schematic) which shows the position of the centre of gravity and the mounting points provided.

The drawing may also allow the evaluation of certain parameters which may be necessary and which are often unknown to either the manufacturers or the users (e.g. moments of inertia).

For passive isolation, it is necessary to obtain the maximum of information about the external vibrations which may disturb the machine.

In any case, for complex problems (oscillations in many degrees of freedom, multiple excitation), it is advisable to consult our Technical Services.

For simple problems (one degree of freedom, or two degrees of freedom with the centre of gravity close to the mounting plane) it is possible to design the suspension, as shown below, with a minimum of information about the machine and the disturbance.

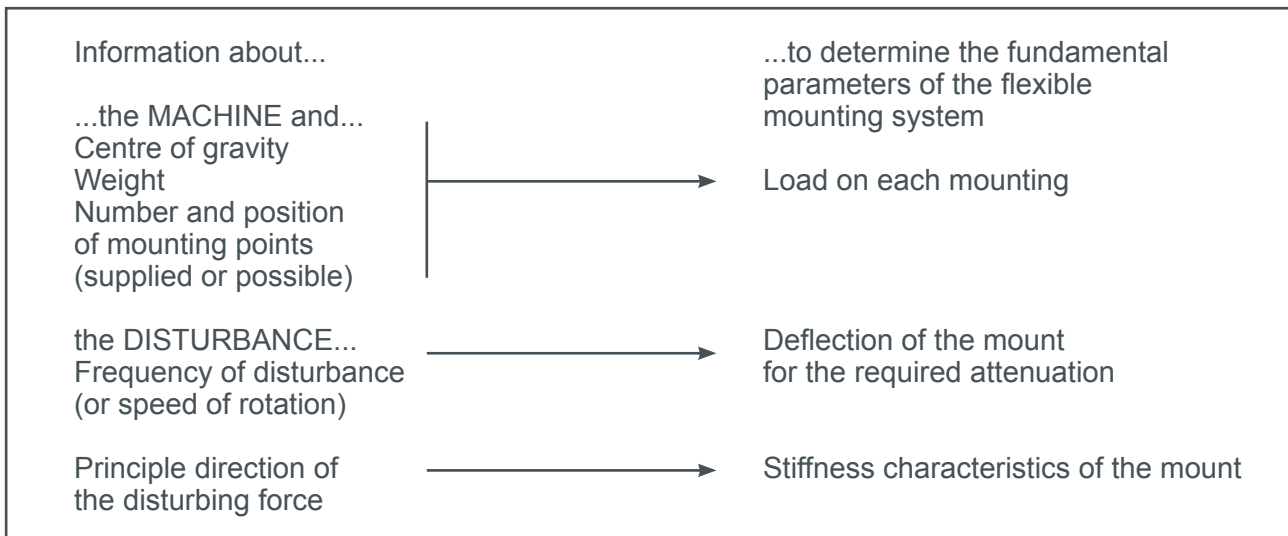

IV.1 - Determining the centre of gravity

IV.1.1 - ASK THE MANUFACTURER

In most cases, the manufacturer of the machine should be able to supply the exact position of the centre of gravity as well as the weight. Consult the manufacturer.

IV.1.2 - GRAPHICAL METHOD FOR FINDING THE CENTRE OF GRAVITY OF AN ASSEMBLY

This is suitable for assemblies of units for which the individual weights and centres of gravity are known.

• **Important notes :**

- Using a graphical method, it is important to represent dimensions using a well determined scale and the weights by vertical lines whose lengths are proportional to their size (e.g. 1 cm for 10 daN).
- If the centres of gravity considered in this section are not in the same vertical plane, the procedures proposed here should be applied twice: for the front and for the side view with the outlines corresponding to each view.

An assembly of two units

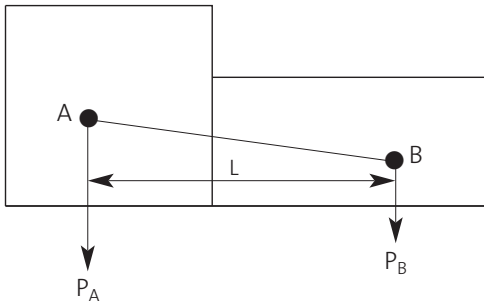

Shape 7

Two units of weights P_A and P_B respectively with centres of gravity A and B separated by L.

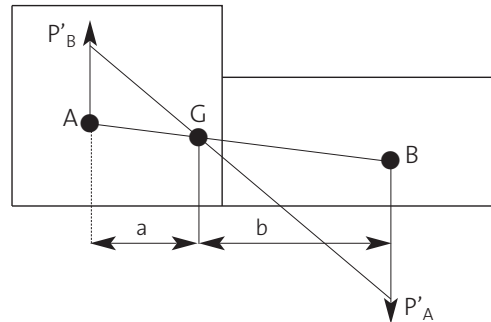

Shape 8

Draw : $AP'B = BP_B$ Join $P'A$ and $P'B$
 $BP'A = AP_A$
 The centre of gravity G lies at the intersection of the lines $P'A P'B$ and AB. Measure a and b.

• **An assembly of three or more units**

Proceed, stage by stage, as described above using groups of two units or sub-assemblies with centres of gravity and weight known or calculated.

Shape 9

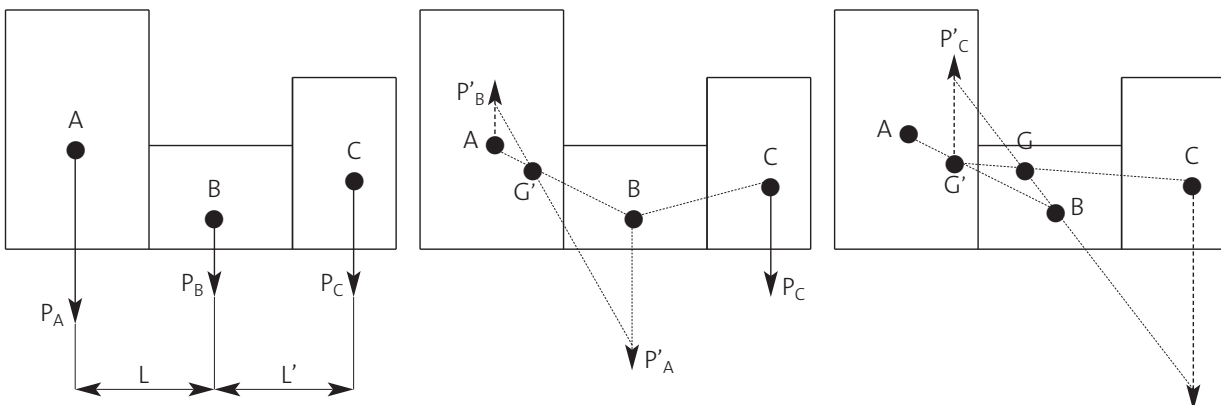

IV.1.3 - EXPERIMENTAL DETERMINATION OF THE CENTRE OF GRAVITY OF A UNIT

This method is used where the above two methods prove to be impossible or difficult (complex geometry).

• **Using a roller**

For a given orientation (length, width and height) the centre of gravity is in the vertical plane passing through the axis of the roller when the machine is balanced. The centre of gravity is at the intersection of the three planes thus determined.

• **By «hanging»**

Suspended from a cable, the centre of gravity is on the vertical dropped from the suspension point. To find the exact centre of gravity, repeat the operation twice, using a different suspension point each time.

IV.1.4 - ANALYTICAL DETERMINATION OF THE CENTRE OF GRAVITY OF AN ASSEMBLY OF SEVERAL MASSES

An assembly of several masses m_1, m_2, \dots, m_n is fixed in space. It is assumed that the coordinates, within an arbitrary Cartesian set, of each mass are known.

$$m_1 \begin{cases} X_1 \\ Y_1 \\ Z_1 \end{cases} \quad m_2 \begin{cases} X_2 \\ Y_2 \\ Z_2 \end{cases} \quad m_n \begin{cases} X_n \\ Y_n \\ Z_n \end{cases}$$

The mass of the assembly $M = m_1 + m_2 + \dots + m_n$ acts at the coordinates of the centre of gravity of the whole : x, y, z .

$$x = \frac{m_1 x_1 + m_2 x_2 + \dots + m_n x_n}{M}$$

$$y = \frac{m_1 y_1 + m_2 y_2 + \dots + m_n y_n}{M}$$

$$z = \frac{m_1 z_1 + m_2 z_2 + \dots + m_n z_n}{M}$$

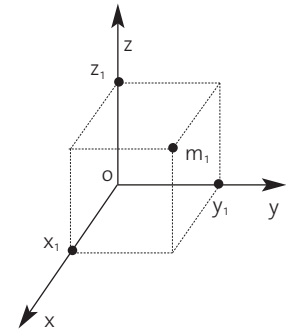

Important note : The coordinates of the centres of gravity may be negative and must be used with their sign.

IV.2 - Determining the load per mount

IV.2.1 - NUMBER AND POSITION OF THE MOUNTING POINTS ARE NOT PREDETERMINED

In this case, the number and position of the mountings are determined in such a way that the load on each mounting is the same for all mounting points.

Taking, for example, a symmetrical machine with :

G : the centre of gravity,
P : the weight of the machine.
Calculate the position of 6 mounting points such that the load on all the mounting points is P_1 .

$$P_1 l'_1 + P_1 l'_2 = P_1 l_1$$

from which $l_1 = l'_1 + l'_2$ and the load per point = $\frac{\text{Weight}}{6}$

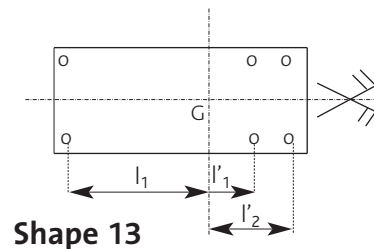

Shape 13

IV.2.2 - NUMBER AND POSITION OF THE MOUNTING POINTS ARE PREDETERMINED

In this case, it may not be possible to have the same load on each mount.

• Four mounting points

A, B, C and D are the mounting points.

G the centre of gravity

P the total weight suspended

P_A, P_B, P_C and P_D are the load on the mounting points A, B, C and D.

$$P_A = \frac{m_2}{b} \cdot \frac{l_2}{a} \cdot P \quad P_B = \frac{m_1}{b} \cdot \frac{l_2}{a} \cdot P$$

$$P_C = \frac{m_1}{b} \cdot \frac{l_1}{a} \cdot P \quad P_D = \frac{m_2}{b} \cdot \frac{l_1}{a} \cdot P$$

If P_A, P_B, P_C and P_D are significantly different, it is, theoretically, necessary to choose four different mounts which will give the same deflection under the various loads.

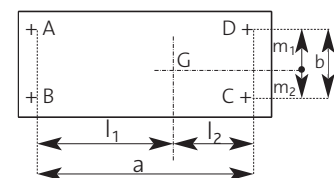

Shape 14

• **More than four mounting points (shape 15)**

In this case it is best if the assembly is symmetrical about a vertical plane. This is assumed to be true in the following.

To the left of G, there are 2n identical mounts.

To the right of G, there are 2p identical mounts which are, possibly, different from the 2n mounts to the left.

The problem is to set the difference between the left hand and right hand mounts so that the deflection under load of the 2n + 2p mounts are all the same.

Under these conditions, all the mounts to the left of G will be supporting the same load Q and all those to the right will be supporting the same load R.

This will give :

$$Q (l_1 + l_2 + \dots + l_n) = (\lambda_1 + \lambda_2 + \dots + \lambda_p) P$$

$$2 nQ + 2 pR = P$$

From which the mounts load is:

$$Q = \frac{\lambda_1 + \lambda_2 + \lambda_p}{2 n (\lambda_1 + \lambda_2 + \dots + \lambda_p) + 2 p (l_1 + l_2 + \dots + l_n)} .P$$

$$R = \frac{l_1 + l_2 + \lambda_p}{2 n (\lambda_1 + \lambda_2 + \dots + \lambda_p) + 2 p (l_1 + l_2 + \dots + l_n)} .P$$

If Q and R are not too different, the same size mounts may be used but with different hardness elastomers.

Example (shape16)

Taking a symmetrical machine with an offset centre of gravity G and 6 mounting points n = 2 et p =1.

which gives :

$$Q = \frac{\lambda}{4 \lambda + 2 (l_1 + l_2)} .P$$

$$R = \frac{l_1 + l_2}{4 \lambda + 2 (l_1 + l_2)} .P$$

If the machine weighs 500 daN

and $\lambda = 0.4$ m; $l_1 = 0.3$ m; $l_2 = 0.9$ m, then $Q = 50$ daN and $R = 150$ daN.

IV.2.3 - IMPORTANT NOTES

If a single size of mount is used, but different hardness elastomers are chosen, there is a high risk that the mount may be interchanged which may degrade the attenuation of the suspension. The machine must be mounted with great care.

There are, however, benefits from using identical mounts to build a suspension. If the predetermined mounting points of the chassis do not allow a centered suspension, the solution is to attach these to a false chassis, as rigid as possible, to which the desired number of identical flexible mounts are attached in the positions required. If this false chassis is a slab of concrete (or inertia block) the suspended mass is increased which improves the quality of the suspension.

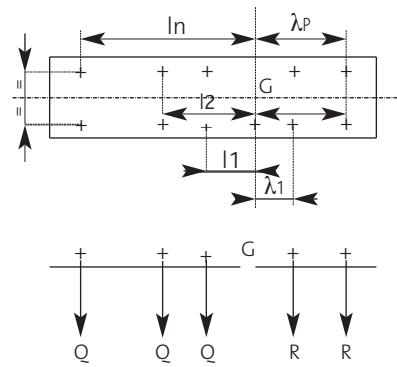

Shape 15

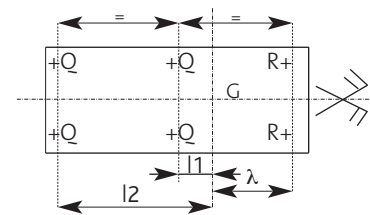

Shape 16

IV.3 - Determining the deflection

IV.3.1 - DEFLECTION AND SUB-TANGENT

Shape 17 is a graphical representation of the derivation of the deflection and sub-tangent from the load/deflection curve.

For a given static load, the deflection corresponds to the compression of the mount under that load, but the stiffness about the position under load is given by the sub-tangent (the projection of the tangent onto the axis). This is the elasticity which determines the natural frequency of the mounting.

$$\omega_0 = \sqrt{\frac{K}{M}} = C \sqrt{\frac{1}{\text{sub-tangent}}}$$

(C = constant)

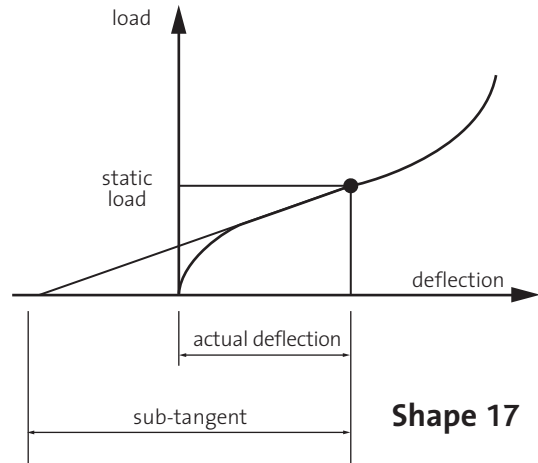

For most PAULSTRA mounts, the load/deflection curve is linear in the region of static loads (shape 18) and, as a result, the sub-tangent and the deflection are identical.

The curve in shape 17 is typical of EVIDGOM mounts.

For these it is best to work at the point of inflection of the curve where the sub-tangent is the largest possible and so the natural frequency is as low as possible.

The deflection does not indicate the amplitude of the oscillations of the machine.

IV.3.2 - OPERATING REGIONS

The region OM is the static load region. The deflection is approximately proportional to the load.

In the data sheets, the coordinates of the point M are given as the NOMINAL STATIC LOAD.

The region MP is the dynamic load region corresponding to normal, repeated shocks provided that the rate and total deflection stay within normal limits.

In the region PZ, which corresponds to exceptional, accidental shocks, the curve rises rapidly.

The stiffness increases progressively which has the effect of reducing the amplitude of the movement. Note that, because of the natural damping properties of the rubber, this increase also depends on the speed of impact.

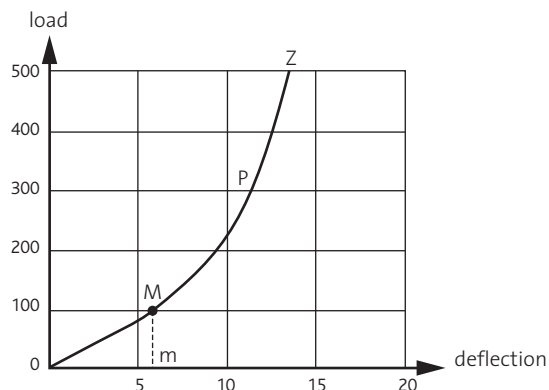



IV.3.3 - ATTENUATION - EXCITATION FREQUENCY

At a given excitation frequency ω , the attenuation depends on the natural frequency ω_0 and thus the sub-tangent. With most rotating machinery, the excitation frequency in cycles per minute can be taken to be the rotation speed in rpm.

As indicated on the chart (shape 6, in § III.2.1.2) for a natural frequency in a known direction, the aim is to obtain the highest possible attenuation within the constraints of the load / deflection characteristics of the mounts.

The deflection selected must not be so high as to be detrimental to the stability of the suspension. If the operating point is not within the vibration isolation zone, our Technical Services should be consulted.

IV.3.4 - STATIC STIFFNESS - DYNAMIC STIFFNESS - NATURAL FREQUENCY

Whereas deflection and sub-tangent are given by the static stiffness curve of the mounting, it's natural frequency is linked to the dynamic stiffness. In the case of elastomeric mountings, static and dynamic stiffness can be different.

The ratio between static and dynamic stiffness depends on the input amplitude, the frequency and the type of elastomer. Under nominal load, the natural frequency is given for indication only.

For a different load, the natural frequency could be found with the following formula:

$$F_p (\text{actual load}) = F_p (\text{nominal load}) \times \sqrt{\frac{\text{nominal load}}{\text{actual load}}}$$

This approximate is valid only if the actual load is in the linear part of the load/deflection curve (shape 17 & 18).

IV.4 - Design examples

PAULSTRA mounts are classified according to their stiffness characteristics

Therefore, after having determined the number and deflection of the mountings as described above, the choice of mounts depends on the direction of the excitation.

- Equi-frequency mounts : the flexibility is approximately the same vertically as horizontally.
- Mounts with high axial flexibility : high axial flexibility while supporting radial loads.
- Mounts with high radial flexibility : high radial flexibility while supporting axial loads.
- Low frequency mountings : high sub-tangent to achieve a very low natural frequency (a few Hertz).

IV.4.1 - SUSPENSION FOR A FAN

• Characteristics of the equipment:

- Weight : 3000 daN.
- Speed of rotation : 1200 rpm.
- Fan mounted on a 2.5 x 3m chassis with no constraint on the position of the mounting fixing points.
- Known centre of gravity.

Number of mounts : after trials, using successive approximation to balance the moments of inertia, 12 mounting points were selected.

Load per mounting = 3000/12 = 250 daN.

Natural frequency of the mounts (see chart).

For an input frequency (or speed of rotation) of 1200 rpm, the maximum natural frequency is 14 Hz. A natural frequency of 7 Hz will achieve a reasonable attenuation of about 85%.

Therefore, a mounting system with a natural frequency of 7 Hz under 250 daN is required.

As it is a rotating machine with no special characteristics, isometric mountings are selected.

The selection guide gives a PAULSTRADYN mount with a 8 mm deflection under a 260 daN load. According to the data sheet for PAULSTRADYN mounts, the PAULSTRADYN Ø 100 hardness 60 has a deflection of 7.4 mm under a load of 240 daN, which is just right.

• Suspension characteristics:

- 12 PAULSTRADYN 260. Mount part number 533712.

- Ratio = $\frac{\text{real load}}{\text{nominal load}} = \frac{250}{260} = 0.96$

- Attenuation ~ 85%*.

- Loaded height ~ 32.5 mm*.

*These values are given by the Paulstradyn data sheet.



IV.4.2 - SUSPENSION OF AN ENGINE/HYDRAULIC PUMP UNIT MOUNTED ON AN EXCAVATOR

- **Characteristics of the assembly :**

- Weight: 1200 daN,
- Speed of rotation : 1500 rpm,
- Known centre of gravity,
- 6 mounting points.

Load per mounting : $1200/6 = 200$ daN.

Deflection (see chart, shape 5).

For a frequency of 1500 rpm, a deflection of 3 mm will achieve an attenuation of approximately 85%.

The vibrations are predominantly vertical and the unit needs to be restrained laterally to cope with the movement of the excavator in operation. Mountings with dominant axial flexibility are selected.

The PAULSTRA mount selection guide shows a STABIFLEX mount with a deflection of 5 mm for a load of 210 daN. According to the STABIFLEX mounting data sheet, the mount required is a STABIFLEX 530622 hardness 45 with a square base.

- **Suspension characteristics (under 1 200 daN at 1 500 tr/mn) :**

- 6 STABIFLEX mounts reference 530622 hardness 45.
- Deflection 4.7 mm.
- Theoretical attenuation 85% (16 dB).

IV.4.3 - SUSPENSION OF A SIEVE

- **Characteristics of the equipment :**

- Weight: 400 daN.
- Vibration frequency (horizontal): 1200 cycles/mn or 20 Hz.
- Known centre of gravity.
- 6 mounting points.

Load per mounting: $400/6 = 66$ daN.

Deflection (see chart, shape 5).

For a frequency of 20 Hz, a deflection of **6 mm** will achieve an attenuation of approximately 70%.

Mount characteristics required:

- 1) mounts which will withstand the vertical load;
- 2) mounts with a radial flexibility very much greater than the axial flexibility (mounting with dominant radial flexibility);
- 3) providing vibration isolation vertically (axially), which, taking account of requirement (2), will assure the horizontal vibration isolation.

The PAULSTRA mount selection guide gives a RADIAFLEX cylindrical stud giving a deflection of 8 mm for a load of 70 daN.

According to the RADIAFLEX mounting data sheet, the mount required is a stud $\varnothing 30$ height 30 mm with 2 mounting bolts (ref. 521312).

The radial flexibility (shear) is considerably higher than axial flexibility (compression).

- **Suspension characteristics :**

- 6 RADIAFLEX cylindrical mounts with 2 screws reference 521312 (theoretical vibration attenuation : 80% - 14 dB).

IV.4.4 - SUSPENSION OF A COMPRESSOR UNIT

- **Characteristics of the assembly :**

- Weight: 6000 daN.
- Speed of rotation : 400 rpm.
- Known centre of gravity.
- 8 mounting points.
- Load per mount: $6000/8 = 750$ daN.

- **Deflection of the mountings :**

For a frequency of 400 rpm, the minimum deflection to be within the vibration isolation region is 12 mm. The PAULSTRA mounting selection guide gives a low frequency mounting which can provide sufficiently large deflections (26 mm).

According to the EVIDGOM mount series data sheet, the mounting required is an EVIDGOM mount Ø 125, height 140 mm, reference 810784 which gives a deflection of 26 mm under a load of 800 daN.

- **Suspension characteristics :**

- 8 EVIDGOM mountings reference 810784, Ø 125 mm, height 140 mm.
- Deflection 26 mm.
- Attenuation 37% (4 dB).

Note : as the low frequency mounts are tall, for some applications (sideways forces) it may be necessary to provide lateral stops.

IV.4.5 - SUSPENSION FROM A CEILING (FALSE CEILING, VENTILATION UNITS, PIPEWORK)

- For light loads of 15 to 135 kg per item our TRAXIFLEX mount may be used directly.

Example of use :

False ceiling - load per mount 50 kg - frequency of excitation 25 Hz - mounting selected 535611 hardness 45 - deflection under load 4 mm - theoretical vibration attenuation 77% - 13 dB.

- For heavy loads, it is necessary to use a PAULSTRADYN, STABIFLEX or EVIDGOM mounting with a safety fixing.

Example of use :

1. Suspending a ventilation unit - weight 1000 daN - frequency 25 Hz - 4 PAULSTRADYN mount Ø 100 reference 533712 - natural frequency. 7 Hz - theoretical vibration attenuation 90% - 20 dB.
2. Suspending a special 5 tonnes machine requiring accurate radial positioning - frequency 20 Hz - 4 STABIFLEX mount reference 530652 hardness 60 - deflection under load 8 mm - theoretical vibration attenuation 84% - 16 dB.
3. Suspending a 20 tonnes tank subject to longitudinal expansion - frequency 15 Hz - 4 EVIDGOM mount reference 810733 hardness 60 - deflection under load 50 mm - theoretical vibration attenuation 95% - 26 dB.

Mounting examples :

