

# series HB

## Screwed-head cylinders

### DESCRIPTION

Cylinders series "HB" are manufactured to be fixed directly on the machinery without the use of fixings accessories. In fact the end caps act as a mounting device in the versions: hinge-mounted, screw-mounted, feet-mounted, front flange-mounted, rear flange-mounted. The double acting hinge-mounted versions and rear flange-mounted are available with reduced end caps. Upon request, cylinders series "HB" comply with ATEX directive, 2GD category.

### TECHNICAL DATA

Operating pressure	1,5 ÷ 10 bar
Working temperature	0 ÷ +80 °C (-20 °C with dry air) 0 ÷ +150 °C with seals for high temperatures (-20 °C with dry air)
Fluid	Filtered, unlubricated, continuous lubricated or dry compressed air
Versions	Double acting; Single acting front spring; Single acting rear spring; Through rod
Bore	Ø 20, 27, 35, 40, 50, 58, 70, 85, 100
Port size	Ø 20 ÷ 50 = G 1/8 Ø 58 ÷ 100 = G 1/4
Standard strokes (mm)	10, 15, 20, 30, 40, 50, 60, 70, 80, 90, 100, 150, 200, 250
Max. strokes double acting (mm)	Ø 20 ÷ 58 = 2000; Ø 70 ÷ 100 = 1000
Maximum strokes single acting	Ø 20 27 35 40 50 58 70 85 100 mm 20 25 35 60 70 60 70 90 100
Maximum strokes single acting (version "S") with spacers	Ø 20 27 35 40 50 58 70 85 100 mm 60 75 105 180 210 180 210 270 300
Spring theoretical tractive force	See technical data on page 0.13



### MATERIALS

End caps	Aluminium alloy
Cylinder barrel	Ø 20 ÷ 100: Extruded tube, anodized aluminium alloy; Extruded tube, brass (supplied upon request)
Piston rod	C45 chromium-plated steel AISI 303 rolled stainless steel
End cap nut	Steel
Piston rod bearing	Bronze-iron 20%, sintered, self-lubricating
Piston guide shoe	Acetal resin
Piston	Aluminium alloy
Seals	NBR rubber Viton®
Springs	Springs steel

### ORDER KEY

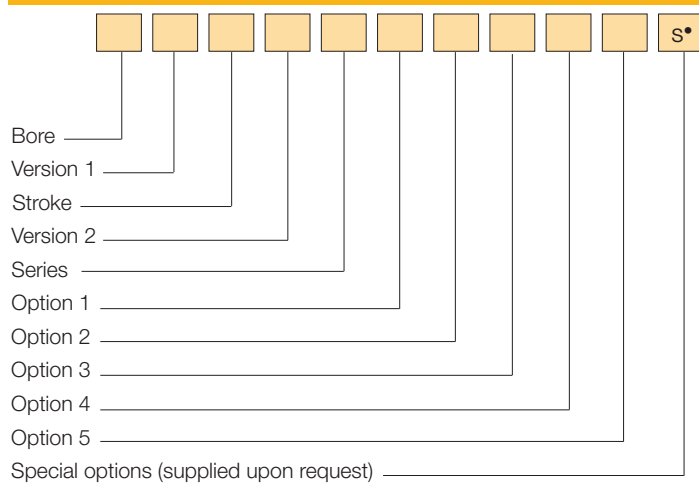

### ORDER EXAMPLES

Basic cylinder Ø 27, 25 mm stroke, single acting front spring, feet-mounted: **27/25 SPB**

Cylinder Ø 20, through rod, 100 mm stroke, double acting, feet-mounted: **20R100 DPB**

Basic cylinder Ø 58, 50 mm stroke, double acting, hinge-mounted, stainless steel piston rod, brass cylinder barrel: **58/50 DVB 14**

Basic cylinder Ø 35, 70 mm stroke, double acting, hinge-mounted, reduced end cap: **35/70 DCBC**

Basic cylinder Ø 40, 50 mm stroke, double acting, hinge-mounted, ATEX: **40/50 DCB/EX**

### VERSION 1

/ Basic cylinder **R** Through rod\*

### VERSION 2

**D** Double acting **Y** Single acting front spring\*\*  
**S** Single acting front spring

### SERIES

**CB** Hinge-mounted **FAB** Front flange-mounted  
**VB** Screw-mounted **FPB** Rear flange-mounted  
**PB** Feet-mounted

### OPTION 1

**C** Reduced end cap\*\*\*

### OPTION 2

**1** Stainless steel piston rod **3** Stainless steel piston rod and seals for high temperatures  
**2** Seals for high temperatures

### OPTION 3

**4** Brass cylinder barrel

### OPTION 4

**5** Rod wipers (supplied as standard from Ø 20 ÷ 70 with option "C" - reduced end cap)

### OPTION 5

/EX Consistent with the ATEX directive II 2GD c T5 T100°C < Ta < 80°C

\* Series "FPB" excluded

\*\* Dimensions are different from the versions "D" and "S"

\*\*\* Supplied only with series "DCB", "YCB", "DFPB", "YFPB" and with the version "R" of series "DFAB" and "DVB"

### SPARE PARTS

SEALS KIT			
NBR	Ø/SG/HB	For high temperatures	Ø/SG/HB2
Through rod NBR	Ø/SG/R/HB	Through rod, for high temperatures	Ø/SG/R/HB2

Screwed-head cylinders

series **HB**

1

BASIC CYLINDER HINGE-MOUNTED - CB

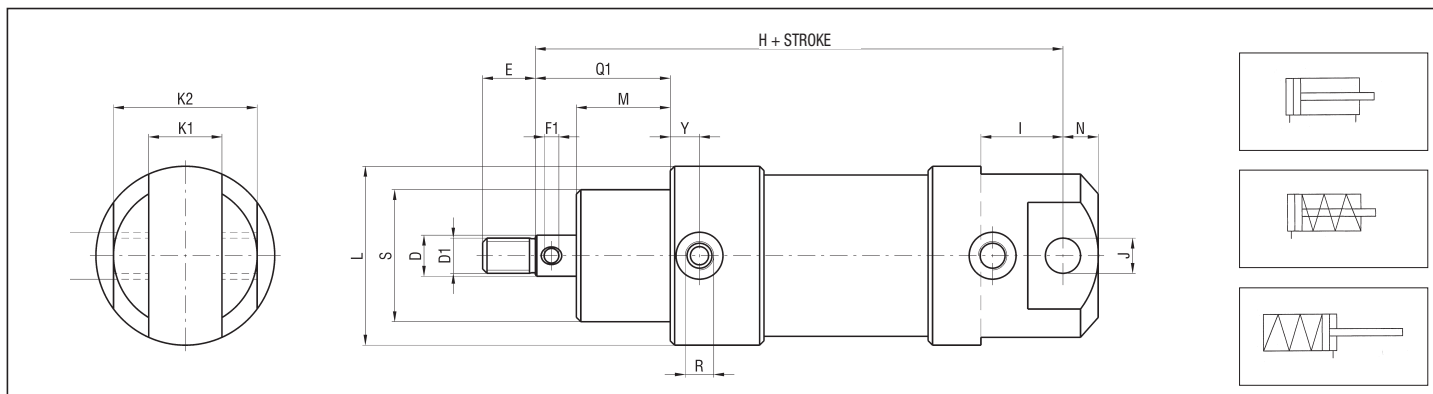

REDUCED END CAP

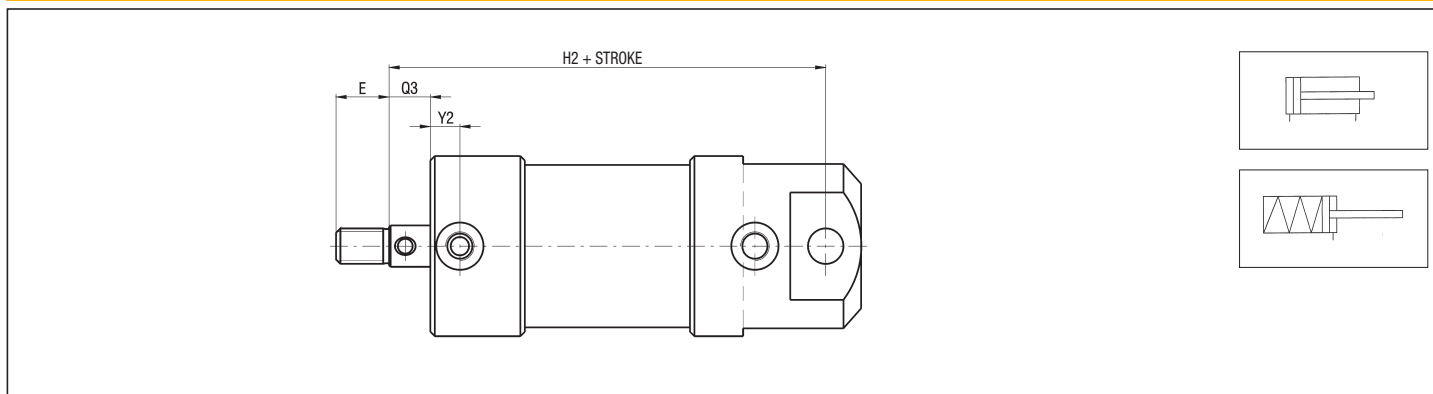

DIMENSIONS AND WEIGHTS BASIC CYLINDER CB

Ø	D	D1	E	F1	H	H2	I	J H8	K1 0/+0,2	K2 0/-0,2	L	M	N	Q1	Q3	R	S	Y	Y2	WEIGHT (g)	INCREM. (g) every 10 mm
20	8	M6	9	3	85	72	10	5	8	22	30	16	6	24	8	G 1/8	24	10	11,5	200	15
27	10	M8	12	4	96	76	21	6	9	25	35	20	7	30	10	G 1/8	28	9,5	11,5	289	20
35	12	M10	15	4	106	84	23	8	12	32	45	24	9	36	12	G 1/8	32	9,5	10	396	32
40	12	M10	15	4	121	90	26	10	18	40	50	32	10	44	12	G 1/8	36	10	10	503	35
50	14	M12	18	5	130	101	28	12	25	49	61	32	12	46	14	G 1/8	42	10	10	793	44
58	16	M14	21	5	140	110	33	14	26	54	70	32	14	48	16	G 1/4	45	12	14	1181	53
70	18	M16	24	5	151	122	35	16	35	67	82	35	16	53	18	G 1/4	50	14	16	1474	64
85	20	M18	27	6	168	128	36	18	40	76	98	44,5	18	64,5	20	G 1/4	60	12,5	14	2033	89
100	24	M20	30	6	191	142	45	20	40	80	114	50	20	74	24	G 1/4	70	14	19	3250	110

ACCESSORIES

PIVOT FOR FEMALE REAR HINGE - STEEL - HB/SEC Ø

Ø	BU	EK f7	EL	WEIGHT (g)
20	28	5	23	4,5
27	31	6	26	7
35	38	8	33	15
40	47	10	41	29
50	56	12	50	50
58	62	14	55	76
70	75	16	68	118
85	84	18	77	168
100	88	20	81	217

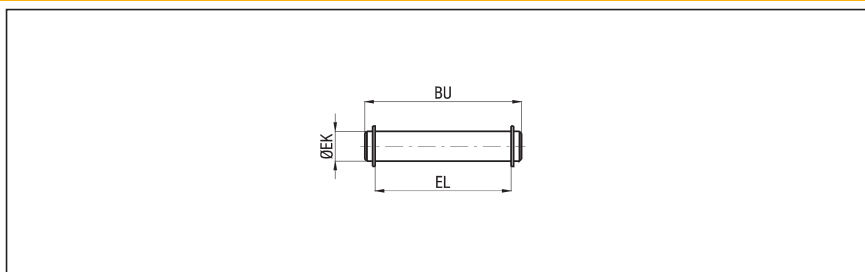

# series HB

## Screwed-head cylinders

### BASIC CYLINDER SCREW-MOUNTED - VB

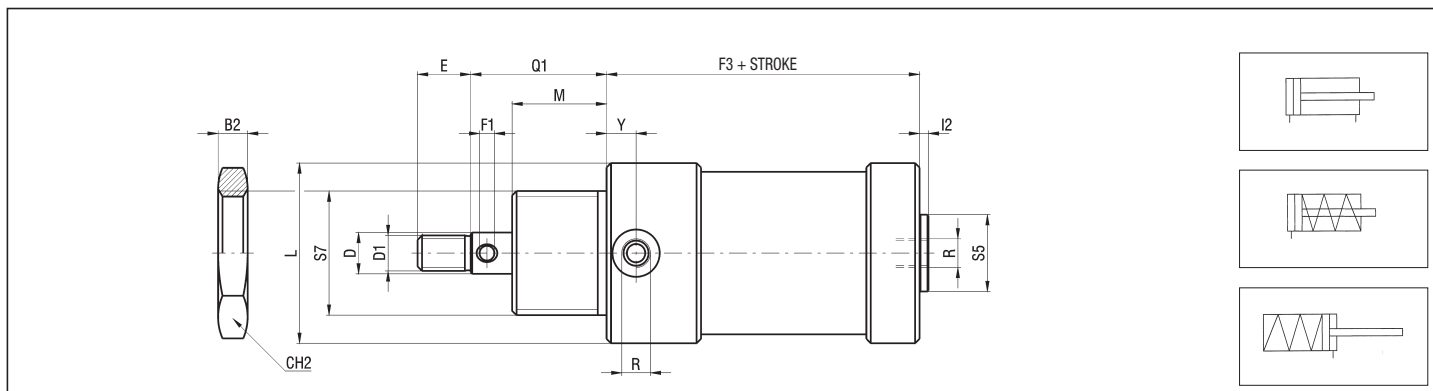

P.S.: End cap nut (HB/DT Ø) supplied as standard. Contact the commercial office for further nuts.

### THROUGH ROD

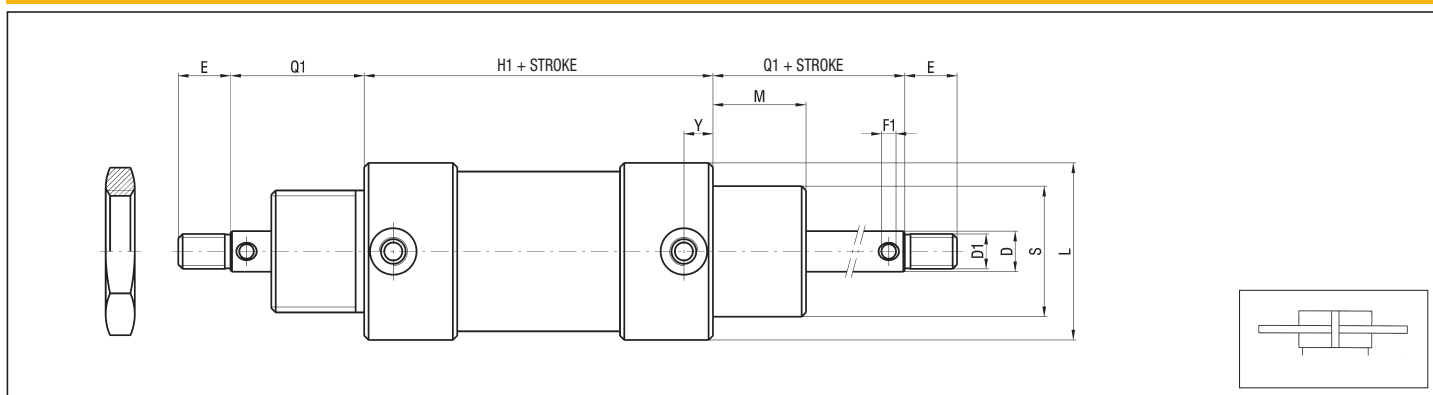

P.S.: End cap nut (HB/DT Ø) supplied as standard. Contact the commercial office for further nuts.

### THROUGH ROD, REDUCED END CAP

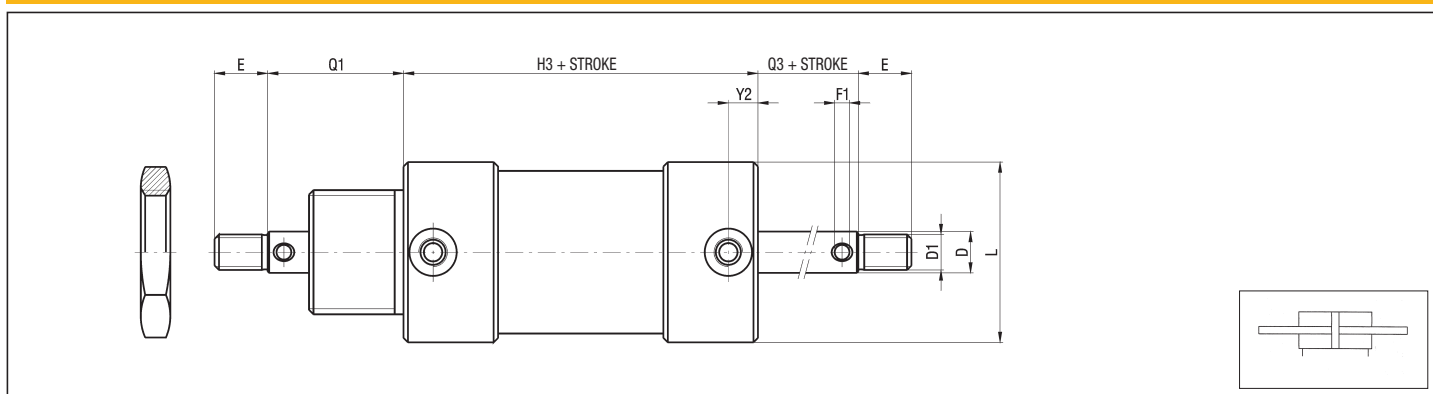

P.S.: End cap nut (HB/DT Ø) supplied as standard. Contact the commercial office for further nuts.

### DIMENSIONS AND WEIGHTS BASIC CYLINDER VB

Ø	B2	CH2	D	D1	E	F1	F3	H1	H3	I2	L	M	Q1	Q3	R	S	S5	S7	Y	Y2	WEIGHT (g)	INCREM. (g) every 10 mm
20	5	32	8	M6	9	3	41	58	61	3,5	30	16	24	8	G 1/8	24	14	M24x2	10	11,5	129	15
27	6	35	10	M8	12	4	45,5	60,5	62,5	3,5	35	20	30	10	G 1/8	28	14	M28x2	9,5	11,5	160	20
35	7	40	12	M10	15	4	47,5	61,5	63,5	3,5	45	24	36	12	G 1/8	32	18	M32x2	9,5	10	299,5	32
40	8	45	12	M10	15	4	51	68	69	3	50	32	44	12	G 1/8	36	24	M36x3	10	10	416	35
50	10	50	14	M12	18	5	56	70	73	3	61	32	46	14	G 1/8	42	26	M42x3	10	10	691	44
58	10	55	16	M14	21	5	59	75	77	4	70	32	48	16	G 1/4	45	30	M45x3	12	14	1028	53
70	10	60	18	M16	24	5	63	80	86	4	82	35	53	18	G 1/4	50	30	M50x3	14	16	1388	64
85	12	70	20	M18	27	6	67,5	84	88,5	4	98	44,5	64,5	20	G 1/4	60	40	M60x4	12,5	14	2024	89
100	14	85	24	M20	30	6	72	89	90	4	114	50	74	24	G 1/4	70	40	M70x4	14	19	3060	110

Screwed-head cylinders

series **HB**

BASIC CYLINDER FEET-MOUNTED - PB

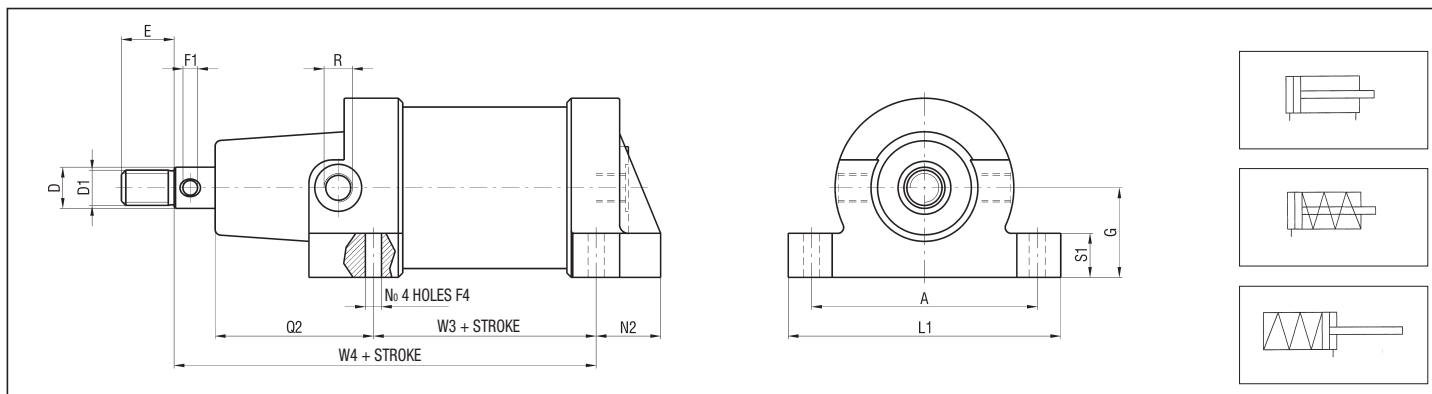

1

THROUGH ROD

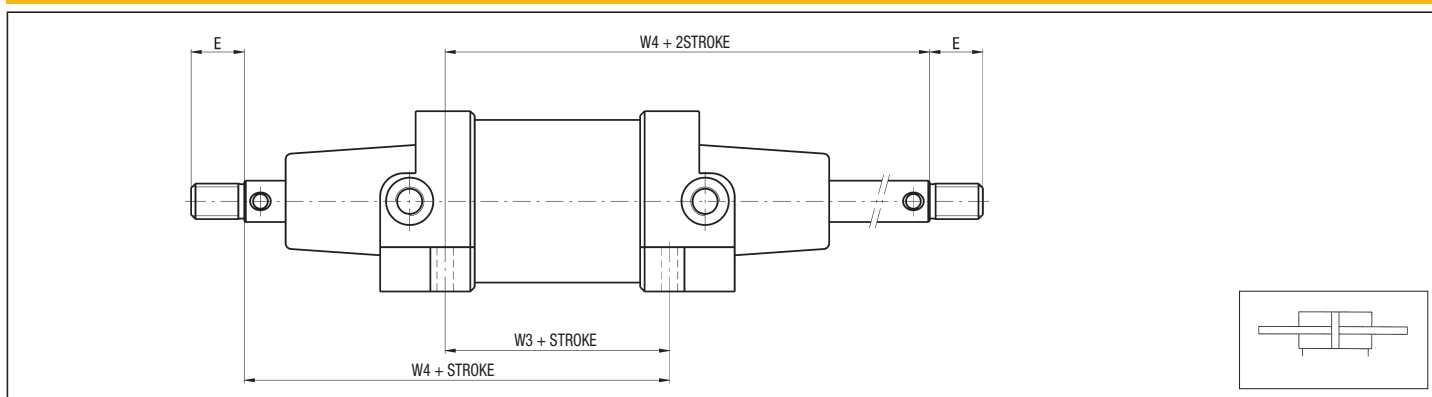

DIMENSIONS AND WEIGHTS BASIC CYLINDER PB

Ø	A	D	D1	E	F1	F4	G	L1	N2	Q2	R	S1	W3	W4	WEIGHT (g)	INCREMENT (g) every 10 mm
20	42	8	M6	9	3	4,25	17	52	13	36	G 1/8	8	18	62	181	15
27	45	10	M8	12	4	4,5	19,5	55	17	40	G 1/8	10	20	70	269	20
35	57	12	M10	15	4	5,5	22,5	69	17	44	G 1/8	12	21	77	359	32
40	64	12	M10	15	4	5,5	25	78	22	56	G 1/8	14	20	88	502	35
50	77	14	M12	18	5	5,5	30,5	93	22	54	G 1/8	16	26	94	743	44
58	86	16	M14	21	5	6,5	35	102	25	56	G 1/4	16	27	99	996	53
70	100	18	M16	24	5	6,5	41	118	26	61	G 1/4	18	28	107	1363	64
85	118	20	M18	27	6	8,5	49	138	27	72	G 1/4	20	30	122	2043	89
100	136	24	M20	30	6	8,5	57	158	28	76	G 1/4	22	33	133	3019	110

# series HB

## Screwed-head cylinders

### BASIC CYLINDER FRONT FLANGE-MOUNTED - FAB

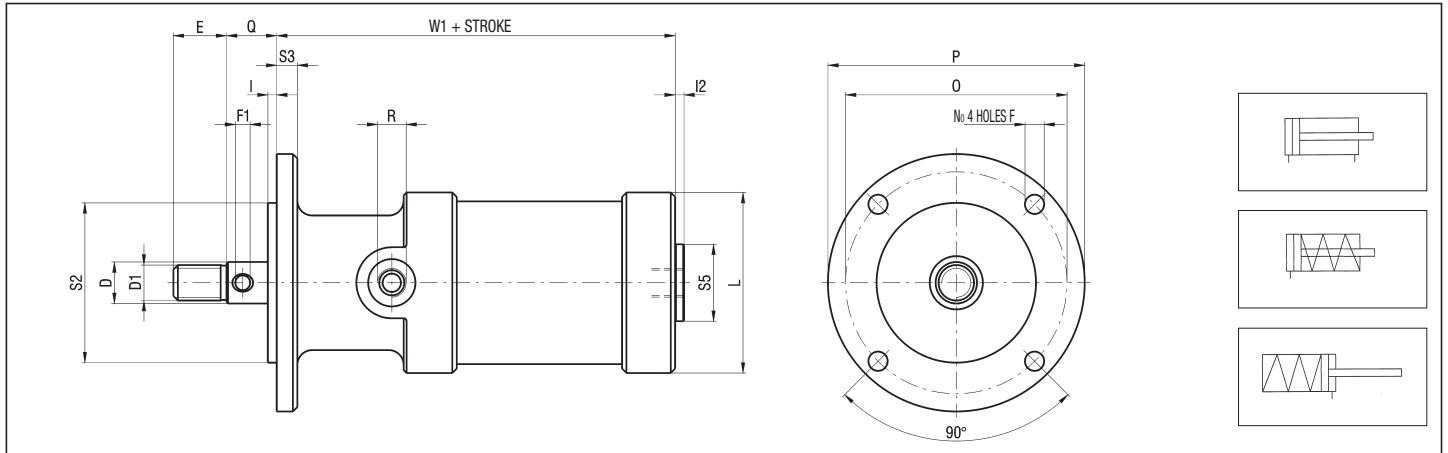

### THROUGH ROD

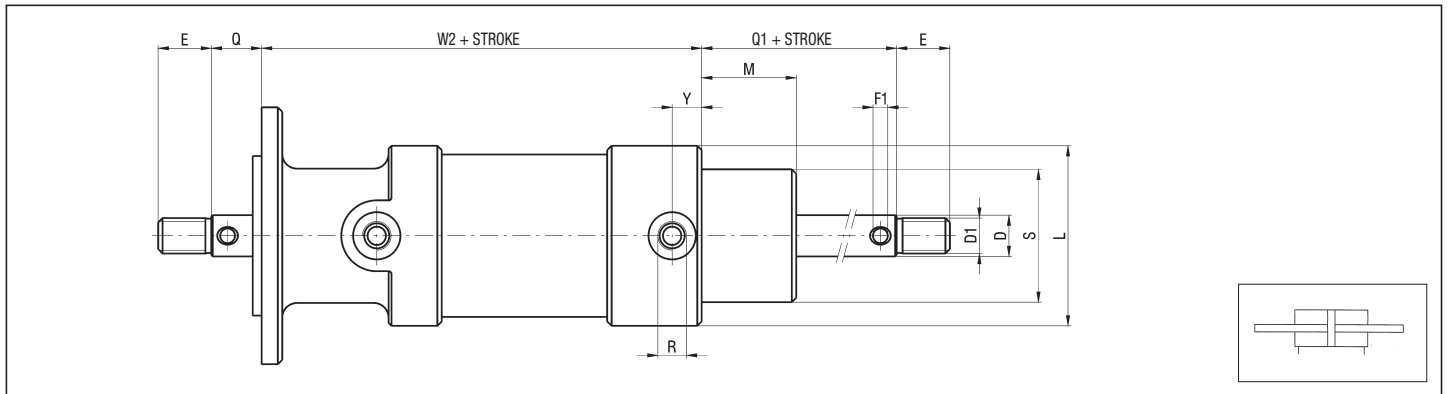

### THROUGH ROD, REDUCED END CAP

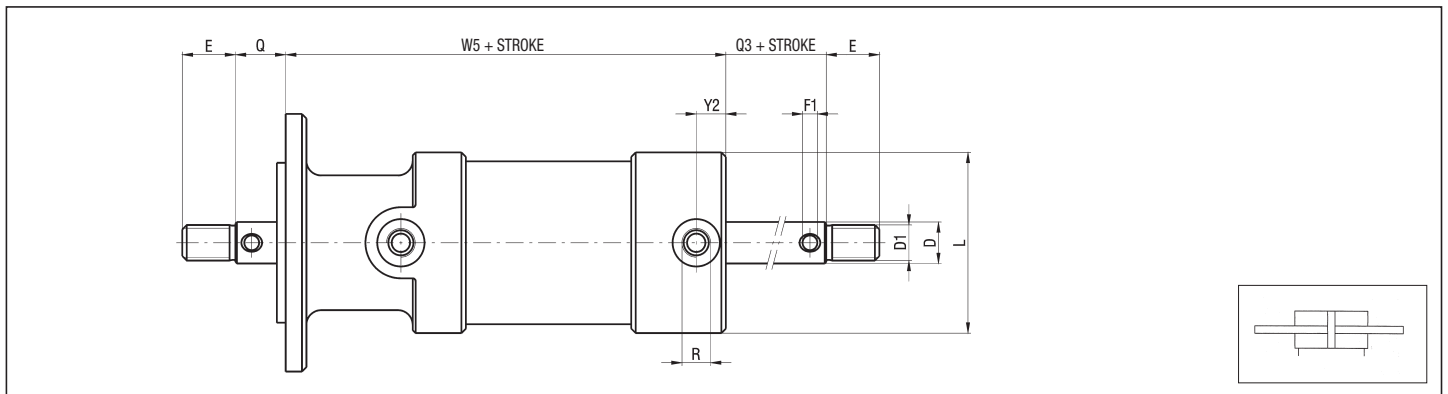

### DIMENSIONS AND WEIGHTS BASIC CYLINDER - FAB

Ø	D	D1	E	F	F1	I	I2	L	M	O	P	Q	Q1	Q3	R	S	S2	S3	S5	W1	W2	W5	Y	Y2	WEIGHT (g)	INCREM. (g) every 10 mm
20	8	M6	9	4,2	3	2	3,5	30	16	39	50	10	24	8	G 1/8	24	23	4	14	55	72	75	10	11,5	91	15
27	10	M8	12	4,5	4	2	3,5	35	20	48	58	12	30	10	G 1/8	28	30	6	14	63,5	78,5	80,5	9,5	11,5	178	20
35	12	M10	15	5,5	4	2	3,5	45	24	54	66	14	36	12	G 1/8	32	36	6	18	69,5	83,5	85,5	9,5	10	317	32
40	12	M10	15	6,5	4	3	3	50	32	57	69	15	44	12	G 1/8	36	40	7	24	80	97	98	10	10	427	35
50	14	M12	18	6,5	5	3	3	61	32	75	87	17	46	14	G 1/8	42	54	7	26	85	99	102	10	10	689	44
58	16	M14	21	6,5	5	3	4	70	32	82	100	19	48	16	G 1/4	45	60	8	30	88	104	106	12	14	915	53
70	18	M16	24	8,5	5	4	4	82	35	100	119	22	53	18	G 1/4	50	70	10	30	94	111	117	14	16	1244	64
85	20	M18	27	10,5	6	4	4	98	44,5	120	140	24	64,5	20	G 1/4	60	80	11	40	103	119,5	124	12,5	14	2113	89
100	24	M20	30	10,5	6	4	4	114	50	137	160	28	74	24	G 1/4	70	88	12	40	118	135	136	14	19	3200	110

Screwed-head cylinders

series **HB**

1

BASIC CYLINDER REAR FLANGE-MOUNTED - FPB

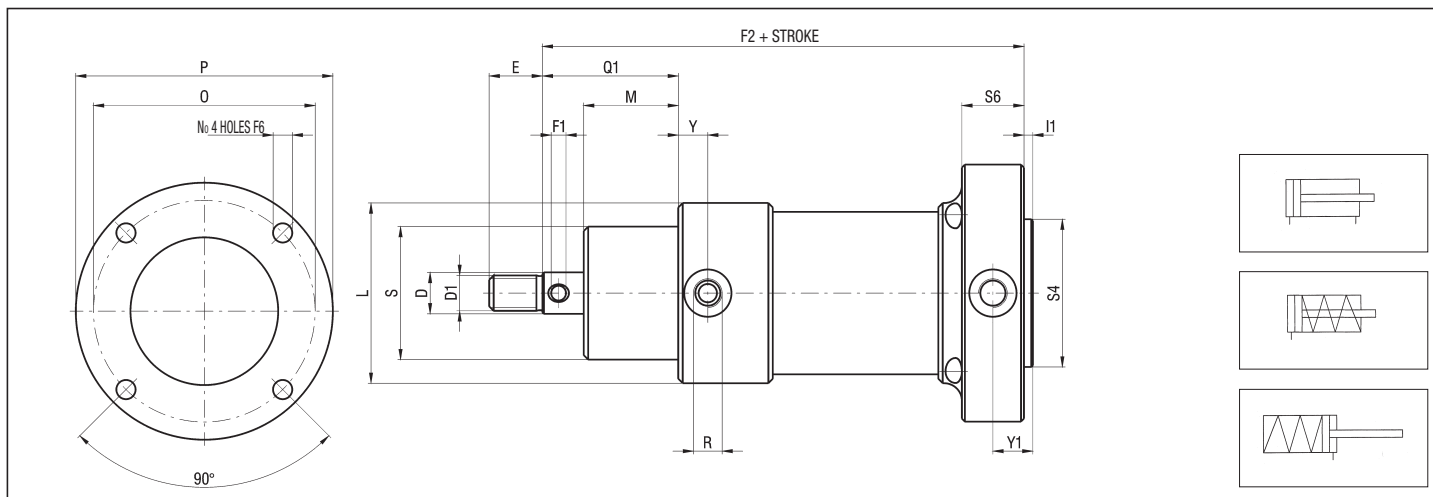

REDUCED END CAP

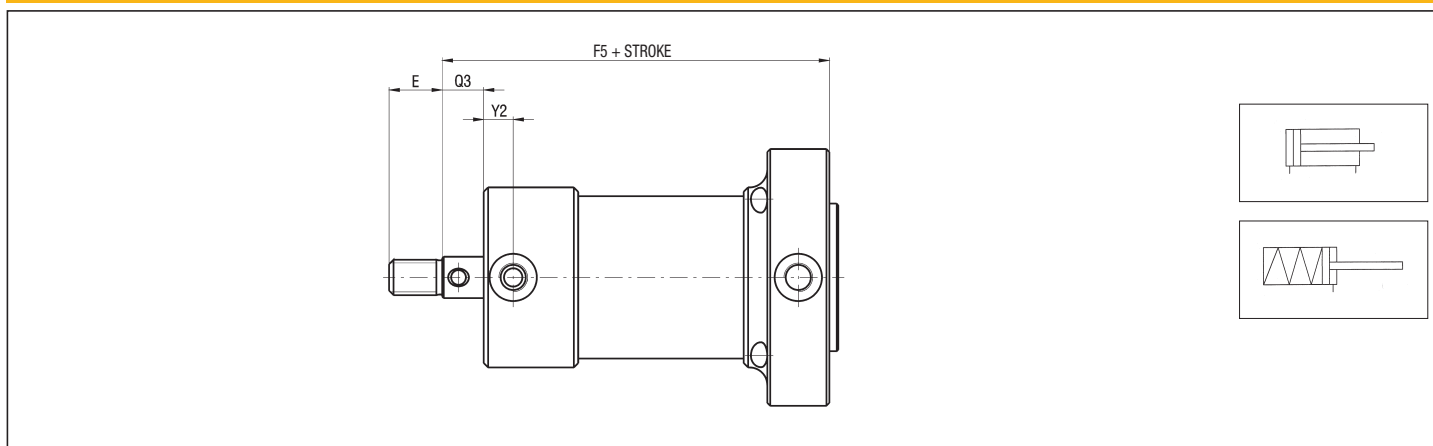

DIMENSIONS AND WEIGHTS BASIC CYLINDER FPB

Ø	D	D1	E	F1	F2	F5	F6	I1	L	M	O	P	Q1	Q3	R	S	S4	S6	Y	Y1	Y2	WEIGHT (g)	INCREM. (g) every 10 mm
20	8	M6	9	3	78	65	4,2	2	30	16	39	50	24	8	G 1/8	24	23	18	10	11	11,5	91	15
27	10	M8	12	4	89	69	4,5	2	35	20	48	58	30	10	G 1/8	28	30	19	9,5	11,5	11,5	178	20
35	12	M10	15	4	97	75	5,5	2	45	24	59	69	36	12	G 1/8	32	38	19	9,5	11,5	10	317	32
40	12	M10	15	4	109	78	5,5	3	50	32	62	74	44	12	G 1/8	36	40	21	10	13,5	10	427	35
50	14	M12	18	5	113	84	6,5	3	61	32	75	87	46	14	G 1/8	42	50	21	10	13,5	10	689	44
58	16	M14	21	5	122	92	8,5	3	70	32	86	100	48	16	G 1/4	45	62	24	12	15	14	915	53
70	18	M16	24	5	131	102	8,5	4	82	35	100	119	53	18	G 1/4	50	72	22	14	15	16	1244	64
85	20	M18	27	6	147	107	10,5	4	98	44,5	120	140	64,5	20	G 1/4	60	80	25	12,5	16,5	14	2113	89
100	24	M20	30	6	164	115	10,5	4	114	50	137	160	74	24	G 1/4	70	88	28	14	18	19	3200	110