

SHELL TYPE NEEDLE ROLLER BEARINGS

- Shell Type Caged Needle Roller Bearings
- Shell Type Grease Retained Full Complement Needle Roller Bearings



Structure and features

IKO Shell Type Needle Roller Bearings are light-weight bearings with large load ratings. They employ a shell type outer ring made from a thin special-steel plate which is accurately drawn, carburized and quenched, thus providing the lowest sectional height among the needle roller bearings.

There are two types of bearings available in this series; the caged type and the full complement type. The appropriate type can be selected according to the operating conditions. The caged type has a structure in which the needle rollers are accurately guided by the cage and thrust rings. It is useful for applications at high-speed rotation. The full complement type needle roller bearing, on the other hand, is suitable for heavy-load applications at low-speed rotation.

Since these bearings are press-fitted into the housing, no fixtures for axial positioning are needed. They are ideal for use in mass-produced articles that require economy, and have a wide variety of applications.

Structures of Shell Type Needle Roller Bearings

Standard Caged Type

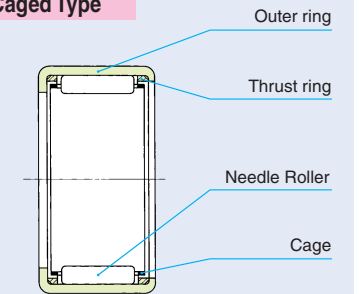

Caged and closed end type

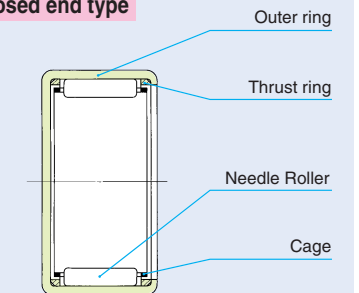

Caged type with two seals

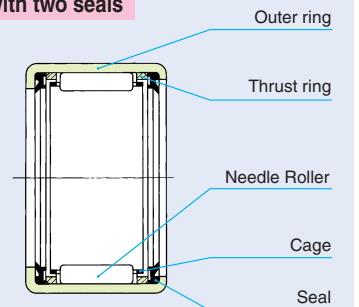

Grease retained full complement type

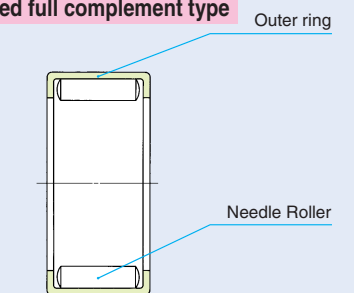

Types

Numerous varieties of Shell Type Needle Roller Bearings are available as shown in Table 1.

Table 1 Type of bearing

| Series | Type | Caged | | | Full complement |
|---------------|------------|-----------|------------|---------------------------|-----------------|
| | | Standard | Closed end | With seals ⁽¹⁾ | Grease retained |
| Metric series | — | TLA ... Z | TLAM | TLA ... UU | YTL |
| | Heavy duty | TA ... Z | TAM | — | YT |
| Inch series | — | BA ... Z | BAM | — | YB |
| | Heavy duty | BHA ... Z | BHAM | — | YBH |

Note⁽¹⁾ When the heavy duty type with seals or the closed end type with one seal is required, please consult .

Remark A "W" is added to the model code to indicate that the rolling elements are of the double-row type.
Example TAW 5045 Z

Shell Type Caged Needle Roller Bearings

Standard type

This type has a narrow gap between the bore of the marked-side flange of the outer ring (brand, bearing number, etc. are marked) and the shaft, which prevents grease leaks and the entry of foreign particles. This type has wide applications.

Closed end type

This type is completely closed on one side of the outer ring, and is ideal for use when perfect closing of shaft ends is desired.

The shape of the closed end surface of the outer ring is divided into two types, and the dimensions t_1 and t_2 in the illustrations shown in the dimension tables apply to the bearings with the roller set bore diameters, $F_w > 22$ and $F_w \leq 22$, respectively.

Type with seals at both sides

This type has a wider outer ring than the standard type and is installed with seals consisting of a reinforcing ring and special synthetic rubber to prevent grease leaks and the entry of foreign particles.

Shell Type Grease Retained Full Complement Needle Roller Bearings

This type has full complement rollers which extend to the full width of the outer ring raceway. It can, therefore, withstand heavy bearing loads and is most suitable for low and medium rotational speeds as well as rocking motions. As lubricating grease is prepacked with the rollers, the bearing can be operated immediately after being fitted.

Identification Number

The identification number of Shell Type Needle Roller Bearings consists of a model code and dimensions. Examples of the arrangement are shown below.

When using with inner rings, the assembled inner rings shown in the dimension tables are used. An example in this case is also shown below. Inner rings are delivered separately.

Examples of identification number

Example 1

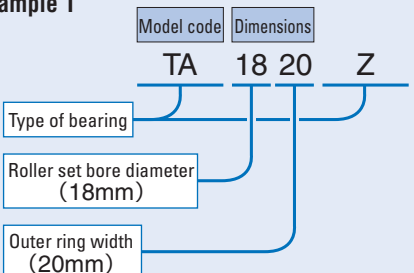

Example 2 (With inner ring)

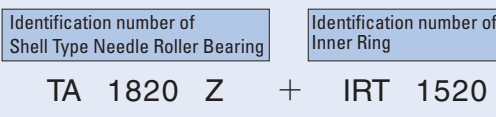

Accuracy

The outer rings of Shell Type Needle Roller Bearings are thin and therefore cannot avoid deformation due to heat treatment. It is thus not appropriate to take direct measurements of the bearing. The roller set bore diameter is measured using a plug gauge or tapered gauge after press-fitting the bearing to a suitable ring gauge. The gauge specifications are shown in Tables 2.1 and 2.2.

Tolerances of outer ring width C are shown in Table 3.

Table 2.1 Measuring gauges for metric series bearings unit: mm

| F_w Nominal roller set bore diameter | Ring gauge | | Plug gauge | |
|--|--|--|------------|--------|
| | TA ... Z ⁽¹⁾ | TLA ... Z ⁽²⁾ | Go | No-go |
| 4 | — | 7.981 | 4.004 | 4.016 |
| 5 | — | 8.981 | 5.004 | 5.016 |
| 6 | — | 9.981 | 6.004 | 6.016 |
| 7 | — | 10.977 | 7.005 | 7.020 |
| 8 | 14.992 | 11.977 | 8.005 | 8.020 |
| 9 | 15.992 | 12.977 | 9.005 | 9.020 |
| 10 | 16.992 | 13.977 | 10.005 | 10.020 |
| 12 | 18.991 | 15.977 ⁽³⁾ 17.977 ⁽³⁾ | 12.006 | 12.024 |
| 13 | — | 18.972 | 13.006 | 13.024 |
| 14 | 21.991 | 19.972 | 14.006 | 14.024 |
| 15 | 21.991 | 20.972 | 15.006 | 15.024 |
| 16 | 23.991 | 21.972 | 16.006 | 16.024 |
| 17 | 23.991 | 22.972 | 17.006 | 17.024 |
| 18 | 24.991 | 23.972 | 18.006 | 18.024 |
| 19 | 26.991 | — | 19.007 | 19.028 |
| 20 | 26.991 ⁽⁴⁾ 27.991 ⁽⁴⁾ | 25.972 | 20.007 | 20.028 |
| 21 | 28.991 | — | 21.007 | 21.028 |
| 22 | 28.991 ⁽⁵⁾ 29.991 ⁽⁵⁾ | 27.972 | 22.007 | 22.028 |
| 24 | 30.989 ⁽⁶⁾ 31.989 ⁽⁶⁾ | — | 24.007 | 24.028 |
| 25 | 32.989 | 31.967 | 25.007 | 25.028 |
| 26 | 33.989 | — | 26.007 | 26.028 |
| 28 | 36.989 | 34.967 | 28.007 | 28.028 |
| 29 | 37.989 | — | 29.007 | 29.028 |
| 30 | 39.989 | 36.967 | 30.007 | 30.028 |
| 32 | 41.989 | — | 32.009 | 32.034 |
| 35 | 44.989 | 41.967 | 35.009 | 35.034 |
| 37 | 46.989 | — | 37.009 | 37.034 |
| 38 | 47.989 | — | 38.009 | 38.034 |
| 40 | 49.989 | 46.967 | 40.009 | 40.034 |
| 45 | 54.988 | 51.961 | 45.009 | 45.034 |
| 50 | 61.988 | 57.961 | 50.009 | 50.034 |
| 55 | 66.988 | 62.961 | 55.010 | 55.040 |
| 60 | 71.988 | — | 60.010 | 60.040 |
| 62 | 73.988 | — | 62.010 | 62.040 |
| 65 | 76.988 | — | 65.010 | 65.040 |
| 70 | 81.987 | — | 70.010 | 70.040 |

Notes⁽¹⁾ Also applicable to TAM and YT
⁽²⁾ Also applicable to TLAM, YTL, TLA...UU
⁽³⁾ The upper value is for TLA 1210Z model, and the lower value is for TLA 1212Z model.
⁽⁴⁾ The lower value is for TA 202820Z model, and the upper value is for models other than TA 202820Z model.
⁽⁵⁾ The lower value is for TA 223016Z and TA 223020Z models, and the upper value is for models other than those models.
⁽⁶⁾ The lower value is for TA 243216Z and TA 243220Z models, and the upper value is for models other than those models.

Table 2.2 Measuring gauges for inch series bearings unit: mm

| F_w Nominal roller set bore diameter | Ring gauge | | | Plug gauge | |
|--|-------------------------|--------------------------|--------|------------|--|
| | BA ... Z ⁽¹⁾ | BHA ... Z ⁽²⁾ | Go | No-go | |
| 3.969 | 7.155 | — | 3.990 | 4.016 | |
| 4.762 | 8.730 | — | 4.783 | 4.808 | |
| 6.350 | 11.125 | — | 6.388 | 6.414 | |
| 7.938 | 12.713 | 14.300 | 7.976 | 8.001 | |
| 9.525 | 14.300 | 15.888 | 9.563 | 9.588 | |
| 11.112 | 15.888 | 17.475 | 11.151 | 11.176 | |
| 12.700 | 17.475 | 19.063 | 12.738 | 12.764 | |
| 14.288 | 19.063 | 20.650 | 14.326 | 14.351 | |
| 15.875 | 20.650 | 22.238 | 15.913 | 15.938 | |
| 17.462 | 22.238 | 23.825 | 17.501 | 17.526 | |
| 19.050 | 25.387 | 26.975 | 19.063 | 19.088 | |
| 20.638 | 26.975 | 28.562 | 20.650 | 20.676 | |
| 22.225 | 28.562 | 30.150 | 22.238 | 22.263 | |
| 23.812 | 30.150 | — | 23.825 | 23.851 | |
| 25.400 | 31.737 | 33.325 | 25.413 | 25.438 | |
| 26.988 | 33.325 | — | 27.000 | 27.026 | |
| 28.575 | 34.912 | 38.087 | 28.588 | 28.613 | |
| 30.162 | 38.087 | — | 30.175 | 30.201 | |
| 31.750 | 38.087 | 41.262 | 31.763 | 31.788 | |
| 33.338 | 41.262 | — | 33.350 | 33.378 | |
| 34.925 | 41.262 | 44.437 | 34.938 | 34.966 | |
| 38.100 | 47.612 | — | 38.113 | 38.143 | |
| 41.275 | 50.787 | — | 41.288 | 41.318 | |
| 44.450 | 53.962 | 57.137 | 44.463 | 44.496 | |
| 47.625 | 57.137 | — | 47.638 | 47.671 | |
| 50.800 | 60.312 | — | 50.815 | 50.848 | |
| 52.388 | — | 64.280 | 52.413 | 52.451 | |
| 53.975 | 63.487 | — | 53.990 | 54.028 | |
| 57.150 | 66.662 | — | 57.165 | 57.203 | |
| 66.675 | 76.187 | — | 66.700 | 66.738 | |
| 69.850 | 79.362 | — | 69.875 | 69.914 | |

Notes⁽¹⁾ Also applicable to BAM and YB
⁽²⁾ Also applicable to BHAM and YBH

Table 3 Tolerances of outer ring width C unit: mm

| Series | Tolerance |
|--------|-----------|
| Metric | 0 ~ -0.20 |
| Inch | 0 ~ -0.25 |

Fit

As the outer ring is thin, the correct dimensions and accuracy of Shell Type Needle Roller Bearings are obtained only after they have been press-fitted into the housing bore. Bearing accuracy is directly affected by housing dimensions, shape and rigidity. This should be taken into account when considering fit and accuracy. The radial clearance after fitting the bearing to the shaft and the housing bore varies with their tolerances.

Table 4 shows the recommended fit for Shell Type Needle Roller Bearings.

Table 5 shows a calculation example of radial clearance after fitting. This calculation applies to bearings without inner ring to be fitted into rigid steel or cast iron housings. When the housing is made of light alloy or a thin steel pipe, it is necessary to check dimensions by actual measurement.

Generally, when making the radial clearance smaller, it is recommended that the shaft diameter be increased, without decreasing the housing bore diameter.

Table 4 Recommended fit

| Type of bearing | Housing material | Tolerance class | | |
|--|----------------------------------|--------------------|-----------------|--------------|
| | | Shaft (1) | | Housing bore |
| | | Without inner ring | With inner ring | |
| TA...Z, BA...Z, BHA...Z, TAM, BAM, BHAM, YT, YB, YBH | Steel Cast iron | h6 | k5(j5) | J7 |
| | Light alloy (Thin steel pipe) | h6 | k5(j5) | M7(N7) |
| TLA...Z, TLAM, YTL, TLA...UU | Steel Cast iron | h6 | k5(j5) | N7 |
| | Light alloy (Thin steel pipe) | h6 | k5(j5) | R7(S7) |

Note(1) When housings are made of light alloy or a thin steel pipe, the roller set bore diameter is greatly affected by the housing thickness and shape. Therefore, before mass-production assembly, assembly tests should be carried out to confirm the amount of dimensional change and to determine the tolerance of the shaft which will give normal clearances.

Table 5 Calculation example of radial clearance after fitting

unit: mm

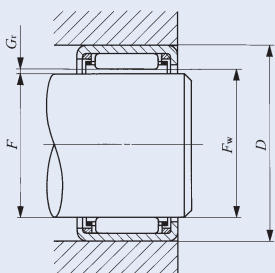
| Calculation procedure | Example of TLA 2020 Z |
|---|--|
|  <p>① Dimension of roller set bore diameter of bearing after it has been press-fitted into the ring gauge. Dimension of ring gauge (D_0): See Tables 2.1 and 2.2 on page B4. Max. value of roller set bore dia. ($F_{w \max}$): No-go dimension of plug gauge Min. value of roller set bore dia. ($F_{w \min}$): Go dimension of plug gauge</p> | From Table 2.1 on page B4 $D_0 = 25.972$ $F_{w \max} = 20.028$ $F_{w \min} = 20.007$ |
| <p>② Dimension of housing bore Max. value of housing bore (D_{\max}): See the dimension table. Min. value of housing bore (D_{\min}): See the dimension table.</p> | From the dimension table on page B14, $D_{\max} = 25.993$ $D_{\min} = 25.972$ |
| <p>③ Dimension of roller set bore diameter of bearing after it has been press-fitted into the housing bore Max. value of roller set bore dia. ($F_{we \max}$) = $(D_{\max} - D_0) + F_{w \max}$ Min. value of roller set bore dia. ($F_{we \min}$) = $(D_{\min} - D_0) + F_{w \min}$</p> | From the equations, $F_{we \max} = 20.049$ $F_{we \min} = 20.007$ |
| <p>④ Dimension of shaft Max. value of shaft dia. (F_{\max}): See the dimension table. Min. value of shaft dia. (F_{\min}): See the dimension table.</p> | From the dimension table on page B14, $F_{\max} = 20.000$ $F_{\min} = 19.987$ |
| <p>⑤ Radial clearance after mounting Max. value of radial clearance ($G_{r \max}$) = $F_{we \max} - F_{\min}$ Min. value of radial clearance ($G_{r \min}$) = $F_{we \min} - F_{\max}$</p> | From the equations, $G_{r \max} = 0.062$ $G_{r \min} = 0.007$ The radial clearance after mounting becomes 0.007~0.062 mm. |

D : Housing bore diameter
 F_w : Roller set bore diameter
 F : Shaft diameter
 G_r : Radial clearance

Lubrication

Bearings with prepacked grease are shown in Table 6. ALVANIA GREASE S2 (SHELL) is prepacked as the lubricating grease.

In the case of bearings without prepacked grease, perform proper lubrication for use. If the bearings are operated without lubrication, the wear of the roller contact surfaces will increase and the bearing life will be shortened.

Oil Hole

For Shell Type Needle Roller Bearings with an oil hole, "OH" is appended to the end of the identification number.

Example TA 2525 Z OH

The symbol "OH" is not marked on the bearing itself, but is shown on its packaging, etc. When bearings with multiple oil holes are required, please consult IKO.

Table 6 Bearings with prepacked grease

○ : With prepacked grease × : Without prepacked grease

| Series | Bearing type | Caged | | | Full complement |
|---------------|----------------|----------|------------|------------|-----------------|
| | | Standard | Closed end | With seals | Grease retained |
| Metric series | TLA, TLAM, YTL | × | × | ○ | ○ |
| | TA, TAM, YT | × | × | — | ○ |
| Inch series | BA, BAM, YB | × | × | — | ○ |
| | BHA, BHAM, YBH | × | × | — | ○ |

Static Safety Factor

Since Shell Type Needle Roller Bearings employ an outer ring made from a thin steel plate which is drawn, carburized and quenched, excessively large loads must be avoided. The required static safety factor is usually more than 3.

Specifications of shaft and housing

Shell Type Needle Roller Bearings are commonly used without an inner ring. In such cases, the surface hardness of the raceway surface should be 58~64HRC and the surface roughness should not exceed $0.2 \mu m R_a$. However, when the operating condition is not severe, a surface roughness $0.8 \mu m R_a$ or less can be used.

If the surface hardness is low, the load rating must be corrected by the hardness factor shown on page A20. When the shaft cannot be heat treated and finished by grinding, the use of IKO Inner Rings for Shell Type Needle Roller Bearings (See page H1.) is recommended.

Mounting

Shell Type Needle Roller Bearings should be pressed into the housings gently using the appropriate tool as shown in Fig. 1, with their marked end surface up. As the outer ring is thin, it must never be struck directly with a hammer.

Since the outer rings of Shell Type Needle Roller Bearings are firmly fitted to housing bores with interference, it is unnecessary to fix them axially. Fig. 2 shows mounting examples.

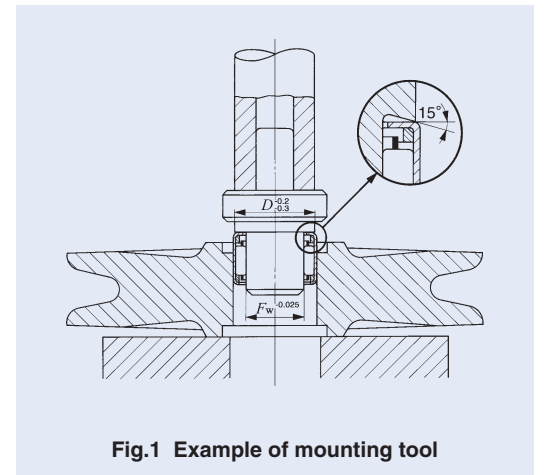

Fig.1 Example of mounting tool

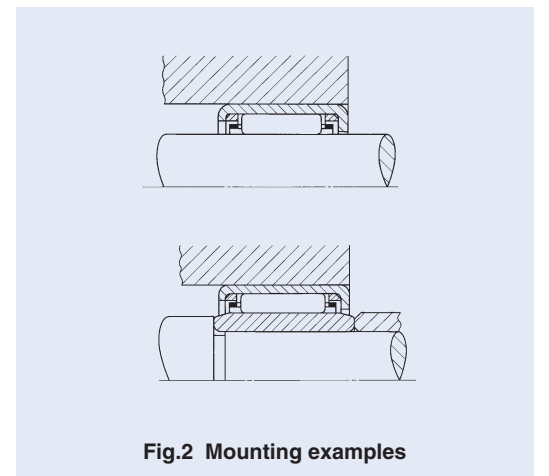

Fig.2 Mounting examples

SHELL TYPE NEEDLE ROLLER BEARINGS



Shaft dia. 29 – 35mm

| Shaft dia. mm | Identification number | | | | | | | | | |
|------------------|-----------------------|------------------|------------|------------------|------------|------------------|------------|------------------|-----------------|------------------|
| | Standard | Mass (Ref.) g | Closed end | Mass (Ref.) g | Standard | Mass (Ref.) g | Closed end | Mass (Ref.) g | Grease retained | Mass (Ref.) g |
| 29 | TA 2920 Z | 47 | TAM 2920 | 52 | — | — | — | — | — | — |
| | TA 2930 Z | 70 | TAM 2930 | 75.5 | — | — | — | — | — | — |
| | — | — | — | — | — | — | — | — | YT 2920 | 58.5 |
| 30 | — | — | — | — | TLA 3012 Z | 23.5 | TLAM 3012 | 29 | — | — |
| | — | — | — | — | TLA 3016 Z | 30.5 | TLAM 3016 | 36 | — | — |
| | — | — | — | — | TLA 3018 Z | 34.5 | TLAM 3018 | 40 | — | — |
| | — | — | — | — | TLA 3020 Z | 38 | TLAM 3020 | 43.5 | — | — |
| | — | — | — | — | TLA 3026 Z | 49 | TLAM 3026 | 54.5 | — | — |
| | — | — | — | — | TLAW3038 Z | 69 | TLAMW3038 | 74.5 | — | — |
| | TA 3013 Z | 36.5 | TAM 3013 | 42.5 | — | — | — | — | — | — |
| | TA 3015 Z | 42 | TAM 3015 | 47.5 | — | — | — | — | — | — |
| | TA 3020 Z | 54.5 | TAM 3020 | 60 | — | — | — | — | — | — |
| | TA 3025 Z | 68 | TAM 3025 | 73.5 | — | — | — | — | — | — |
| TA 3030 Z | 80 | TAM 3030 | 85.5 | — | — | — | — | — | — | |
| 32 | TA 3220 Z | 57.5 | TAM 3220 | 63.5 | — | — | — | — | — | — |
| | TA 3230 Z | 86 | TAM 3230 | 97.5 | — | — | — | — | — | — |
| | — | — | — | — | — | — | — | — | YT 3220 | 71.5 |
| 35 | — | — | — | — | TLA 3512 Z | 27 | TLAM 3512 | 34.5 | — | — |
| | — | — | — | — | TLA 3516 Z | 35 | TLAM 3516 | 42.5 | — | — |
| | — | — | — | — | TLA 3520 Z | 43.5 | TLAM 3520 | 51 | — | — |
| | TA 3512 Z | 38.5 | TAM 3512 | 46 | — | — | — | — | — | — |
| | TA 3515 Z | 48 | TAM 3515 | 56 | — | — | — | — | — | — |
| | TA 3520 Z | 62.5 | TAM 3520 | 70 | — | — | — | — | — | — |
| TA 3525 Z | 78 | TAM 3525 | 85.5 | — | — | — | — | — | — | |
| TA 3530 Z | 97 | TAM 3530 | 105 | — | — | — | — | — | — | |

Note(1) Allowable rotational speed applies to oil lubrication. For grease lubrication, a maximum of 60% of this value is allowable.
 Remarks1. "W" in the identification number indicates that rolling elements are arranged in double rows.
 2. Shell Type Grease Retained Full Complement Needle Roller Bearings are provided with prepacked grease. Standard type and closed end type bearings are not provided with prepacked grease, so perform proper lubrication when using these types of bearings.

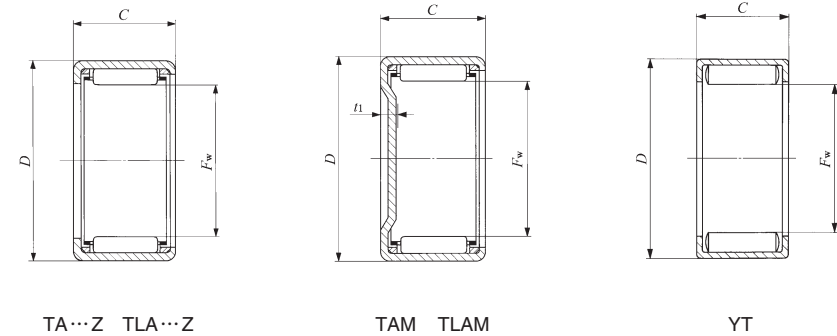

| Boundary dimensions mm | | | | Standard mounting dimensions mm | | | | | | Basic dynamic load rating C | Basic static load rating C ₀ | Allowable rotational speed ⁽¹⁾ rpm | Assembled inner ring |
|------------------------|----|----|------------------------|---------------------------------|--------|----------------------------|--------|--------|--------|--------------------------------|--|--|----------------------|
| F _w | D | C | t ₁ Max. | Shaft dia. h6 | | Housing bore dia. J7 N7 | | | | | | | |
| | | | | Max. | Min. | Max. | Min. | Max. | Min. | N | N | | |
| 29 | 38 | 20 | 3.4 | | | | | | | 22 000 | 34 200 | 13 000 | IRT 2520 |
| 29 | 38 | 30 | 3.4 | 29.000 | 28.987 | 38.014 | 37.989 | — | — | 34 200 | 60 300 | 13 000 | IRT 2530 |
| 29 | 38 | 20 | — | | | | | | | 35 500 | 64 100 | 5 000 | IRT 2520 |
| 30 | 37 | 12 | 2.8 | | | | | | | 10 400 | 16 600 | 12 000 | — |
| 30 | 37 | 16 | 2.8 | | | | | | | 14 100 | 24 500 | 12 000 | — |
| 30 | 37 | 18 | 2.8 | | | | | | | 16 400 | 29 800 | 12 000 | — |
| 30 | 37 | 20 | 2.8 | 30.000 | 29.987 | — | — | 36.992 | 36.967 | 18 600 | 35 100 | 12 000 | IRT 2520-1 |
| 30 | 37 | 26 | 2.8 | | | | | | | 24 800 | 50 900 | 12 000 | IRT 2526-1 |
| 30 | 37 | 38 | 2.8 | | | | | | | 31 900 | 70 200 | 12 000 | IRT 2538-1 |
| 30 | 40 | 13 | 3.4 | | | | | | | 13 500 | 16 800 | 12 000 | — |
| 30 | 40 | 15 | 3.4 | | | | | | | 16 800 | 22 400 | 12 000 | IRT 2515-1 |
| 30 | 40 | 20 | 3.4 | 30.000 | 29.987 | 40.014 | 39.989 | — | — | 24 500 | 36 300 | 12 000 | IRT 2520-1 |
| 30 | 40 | 25 | 3.4 | | | | | | | 31 600 | 50 300 | 12 000 | IRT 2525-1 |
| 30 | 40 | 30 | 3.4 | | | | | | | 36 700 | 60 700 | 12 000 | IRT 2530-1 |
| 32 | 42 | 20 | 3.4 | | | | | | | 25 400 | 38 600 | 11 000 | IRT 2820 |
| 32 | 42 | 30 | 3.4 | 32.000 | 31.984 | 42.014 | 41.989 | — | — | 39 500 | 68 400 | 11 000 | IRT 2830 |
| 32 | 42 | 20 | — | | | | | | | 39 900 | 70 100 | 4 500 | IRT 2820 |
| 35 | 42 | 12 | 2.8 | | | | | | | 11 600 | 20 000 | 10 000 | IRT 3012 |
| 35 | 42 | 16 | 2.8 | 35.000 | 34.984 | — | — | 41.992 | 41.967 | 15 700 | 29 600 | 10 000 | — |
| 35 | 42 | 20 | 2.8 | | | | | | | 20 700 | 42 300 | 10 000 | IRT 3020 |
| 35 | 45 | 12 | 3.4 | | | | | | | 14 800 | 19 900 | 10 000 | IRT 3012 |
| 35 | 45 | 15 | 3.4 | | | | | | | 18 500 | 26 500 | 10 000 | IRT 3015 |
| 35 | 45 | 20 | 3.4 | 35.000 | 34.984 | 45.014 | 44.989 | — | — | 27 000 | 43 100 | 10 000 | IRT 3020 |
| 35 | 45 | 25 | 3.4 | | | | | | | 34 800 | 59 700 | 10 000 | IRT 3025 |
| 35 | 45 | 30 | 3.4 | | | | | | | 40 600 | 72 600 | 10 000 | IRT 3030 |