

# SHELL TYPE NEEDLE ROLLER BEARINGS

- Shell Type Caged Needle Roller Bearings
- Shell Type Grease Retained Full Complement Needle Roller Bearings



## Structure and features

IKO Shell Type Needle Roller Bearings are light-weight bearings with large load ratings. They employ a shell type outer ring made from a thin special-steel plate which is accurately drawn, carburized and quenched, thus providing the lowest sectional height among the needle roller bearings.

There are two types of bearings available in this series; the caged type and the full complement type. The appropriate type can be selected according to the operating conditions. The caged type has a structure in which the needle rollers are accurately guided by the cage and thrust rings. It is useful for applications at high-speed rotation. The full complement type needle roller bearing, on the other hand, is suitable for heavy-load applications at low-speed rotation.

Since these bearings are press-fitted into the housing, no fixtures for axial positioning are needed. They are ideal for use in mass-produced articles that require economy, and have a wide variety of applications.

### Structures of Shell Type Needle Roller Bearings

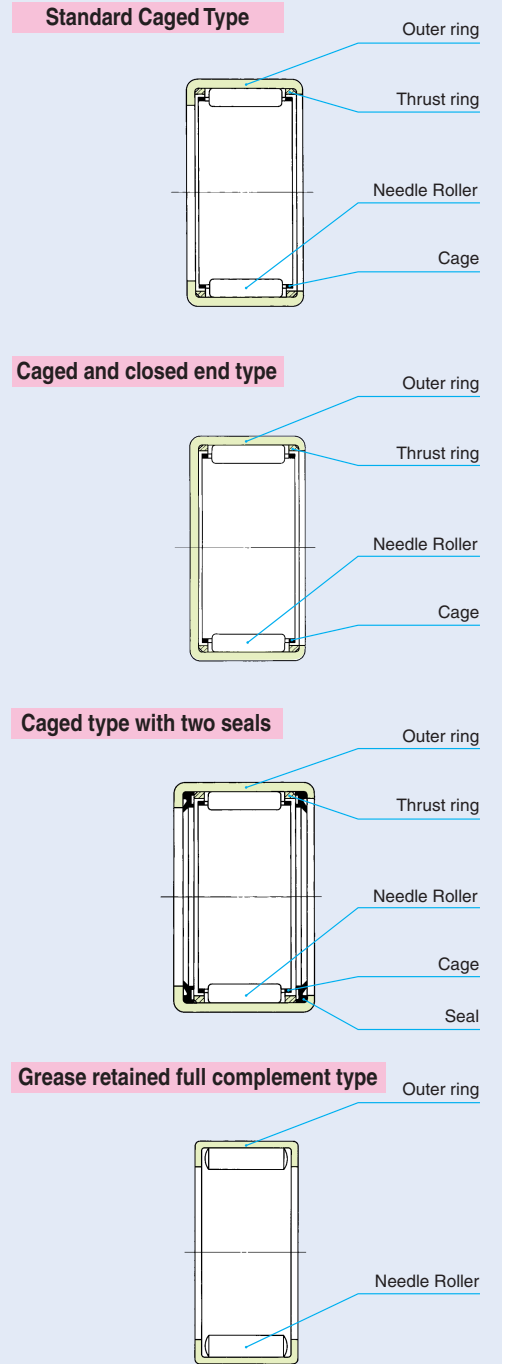

## Types

Numerous varieties of Shell Type Needle Roller Bearings are available as shown in Table 1.

Table 1 Type of bearing

Series	Type	Caged			Full complement
		Standard	Closed end	With seals <sup>(1)</sup>	Grease retained
Metric series	—	TLA ... Z	TLAM	TLA ... UU	YTL
	Heavy duty	TA ... Z	TAM	—	YT
Inch series	—	BA ... Z	BAM	—	YB
	Heavy duty	BHA ... Z	BHAM	—	YBH

Note<sup>(1)</sup> When the heavy duty type with seals or the closed end type with one seal is required, please consult IKO.

Remark A "W" is added to the model code to indicate that the rolling elements are of the double-row type.  
Example TAW 5045 Z

## Shell Type Caged Needle Roller Bearings

### Standard type

This type has a narrow gap between the bore of the marked-side flange of the outer ring (brand, bearing number, etc. are marked) and the shaft, which prevents grease leaks and the entry of foreign particles. This type has wide applications.

### Closed end type

This type is completely closed on one side of the outer ring, and is ideal for use when perfect closing of shaft ends is desired.

The shape of the closed end surface of the outer ring is divided into two types, and the dimensions  $t_1$  and  $t_2$  in the illustrations shown in the dimension tables apply to the bearings with the roller set bore diameters,  $F_w > 22$  and  $F_w \leq 22$ , respectively.

### Type with seals at both sides

This type has a wider outer ring than the standard type and is installed with seals consisting of a reinforcing ring and special synthetic rubber to prevent grease leaks and the entry of foreign particles.

## Shell Type Grease Retained Full Complement Needle Roller Bearings

This type has full complement rollers which extend to the full width of the outer ring raceway. It can, therefore, withstand heavy bearing loads and is most suitable for low and medium rotational speeds as well as rocking motions. As lubricating grease is prepacked with the rollers, the bearing can be operated immediately after being fitted.

## Identification Number

The identification number of Shell Type Needle Roller Bearings consists of a model code and dimensions. Examples of the arrangement are shown below.

When using with inner rings, the assembled inner rings shown in the dimension tables are used. An example in this case is also shown below. Inner rings are delivered separately.

**Examples of identification number**

**Example 1**

**Example 2 (With inner ring)**

Identification number of Shell Type Needle Roller Bearing: TA 1820 Z

Identification number of Inner Ring: IRT 1520

TA 1820 Z + IRT 1520

## Accuracy

The outer rings of Shell Type Needle Roller Bearings are thin and therefore cannot avoid deformation due to heat treatment. It is thus not appropriate to take direct measurements of the bearing. The roller set bore diameter is measured using a plug gauge or tapered gauge after press-fitting the bearing to a suitable ring gauge. The gauge specifications are shown in Tables 2.1 and 2.2.

Tolerances of outer ring width  $C$  are shown in Table 3.

Table 2.1 Measuring gauges for metric series bearings unit: mm

$F_w$ Nominal roller set bore diameter	Ring gauge		Plug gauge	
	TA ... Z <sup>(1)</sup>	TLA ... Z <sup>(2)</sup>	Go	No-go
4	—	7.981	4.004	4.016
5	—	8.981	5.004	5.016
6	—	9.981	6.004	6.016
7	—	10.977	7.005	7.020
8	14.992	11.977	8.005	8.020
9	15.992	12.977	9.005	9.020
10	16.992	13.977	10.005	10.020
12	18.991	15.977 <sup>(3)</sup> 17.977 <sup>(3)</sup>	12.006	12.024
13	—	18.972	13.006	13.024
14	21.991	19.972	14.006	14.024
15	21.991	20.972	15.006	15.024
16	23.991	21.972	16.006	16.024
17	23.991	22.972	17.006	17.024
18	24.991	23.972	18.006	18.024
19	26.991	—	19.007	19.028
20	26.991 <sup>(4)</sup> 27.991 <sup>(4)</sup>	25.972	20.007	20.028
21	28.991	—	21.007	21.028
22	28.991 <sup>(5)</sup> 29.991 <sup>(5)</sup>	27.972	22.007	22.028
24	30.989 <sup>(6)</sup> 31.989 <sup>(6)</sup>	—	24.007	24.028
25	32.989	31.967	25.007	25.028
26	33.989	—	26.007	26.028
28	36.989	34.967	28.007	28.028
29	37.989	—	29.007	29.028
30	39.989	36.967	30.007	30.028
32	41.989	—	32.009	32.034
35	44.989	41.967	35.009	35.034
37	46.989	—	37.009	37.034
38	47.989	—	38.009	38.034
40	49.989	46.967	40.009	40.034
45	54.988	51.961	45.009	45.034
50	61.988	57.961	50.009	50.034
55	66.988	62.961	55.010	55.040
60	71.988	—	60.010	60.040
62	73.988	—	62.010	62.040
65	76.988	—	65.010	65.040
70	81.987	—	70.010	70.040

Notes<sup>(1)</sup> Also applicable to TAM and YT  
<sup>(2)</sup> Also applicable to TLAM, YTL, TLA...UU  
<sup>(3)</sup> The upper value is for TLA 1210Z model, and the lower value is for TLA 1212Z model.  
<sup>(4)</sup> The lower value is for TA 202820Z model, and the upper value is for models other than TA 202820Z model.  
<sup>(5)</sup> The lower value is for TA 223016Z and TA 223020Z models, and the upper value is for models other than those models.  
<sup>(6)</sup> The lower value is for TA 243216Z and TA 243220Z models, and the upper value is for models other than those models.

Table 2.2 Measuring gauges for inch series bearings unit: mm

$F_w$ Nominal roller set bore diameter	Ring gauge			Plug gauge	
	BA ... Z <sup>(1)</sup>	BHA ... Z <sup>(2)</sup>	Go	No-go	
3.969	7.155	—	3.990	4.016	
4.762	8.730	—	4.783	4.808	
6.350	11.125	—	6.388	6.414	
7.938	12.713	14.300	7.976	8.001	
9.525	14.300	15.888	9.563	9.588	
11.112	15.888	17.475	11.151	11.176	
12.700	17.475	19.063	12.738	12.764	
14.288	19.063	20.650	14.326	14.351	
15.875	20.650	22.238	15.913	15.938	
17.462	22.238	23.825	17.501	17.526	
19.050	25.387	26.975	19.063	19.088	
20.638	26.975	28.562	20.650	20.676	
22.225	28.562	30.150	22.238	22.263	
23.812	30.150	—	23.825	23.851	
25.400	31.737	33.325	25.413	25.438	
26.988	33.325	—	27.000	27.026	
28.575	34.912	38.087	28.588	28.613	
30.162	38.087	—	30.175	30.201	
31.750	38.087	41.262	31.763	31.788	
33.338	41.262	—	33.350	33.378	
34.925	41.262	44.437	34.938	34.966	
38.100	47.612	—	38.113	38.143	
41.275	50.787	—	41.288	41.318	
44.450	53.962	57.137	44.463	44.496	
47.625	57.137	—	47.638	47.671	
50.800	60.312	—	50.815	50.848	
52.388	—	64.280	52.413	52.451	
53.975	63.487	—	53.990	54.028	
57.150	66.662	—	57.165	57.203	
66.675	76.187	—	66.700	66.738	
69.850	79.362	—	69.875	69.914	

Notes<sup>(1)</sup> Also applicable to BAM and YB  
<sup>(2)</sup> Also applicable to BHAM and YBH

Table 3 Tolerances of outer ring width  $C$  unit: mm

Series	Tolerance
Metric	0 ~ -0.20
Inch	0 ~ -0.25

## Fit

As the outer ring is thin, the correct dimensions and accuracy of Shell Type Needle Roller Bearings are obtained only after they have been press-fitted into the housing bore. Bearing accuracy is directly affected by housing dimensions, shape and rigidity. This should be taken into account when considering fit and accuracy. The radial clearance after fitting the bearing to the shaft and the housing bore varies with their tolerances.

Table 4 shows the recommended fit for Shell Type Needle Roller Bearings.

Table 5 shows a calculation example of radial clearance after fitting. This calculation applies to bearings without inner ring to be fitted into rigid steel or cast iron housings. When the housing is made of light alloy or a thin steel pipe, it is necessary to check dimensions by actual measurement.

Generally, when making the radial clearance smaller, it is recommended that the shaft diameter be increased, without decreasing the housing bore diameter.

Table 4 Recommended fit

Type of bearing	Housing material	Tolerance class		
		Shaft (1)		Housing bore
		Without inner ring	With inner ring	
TA...Z, BA...Z, BHA...Z, TAM, BAM, BHAM, YT, YB, YBH	Steel Cast iron	h6	k5(j5)	J7
	Light alloy (Thin steel pipe)	h6	k5(j5)	M7(N7)
TLA...Z, TLAM, YTL, TLA...UU	Steel Cast iron	h6	k5(j5)	N7
	Light alloy (Thin steel pipe)	h6	k5(j5)	R7(S7)

Note(1) When housings are made of light alloy or a thin steel pipe, the roller set bore diameter is greatly affected by the housing thickness and shape. Therefore, before mass-production assembly, assembly tests should be carried out to confirm the amount of dimensional change and to determine the tolerance of the shaft which will give normal clearances.

Table 5 Calculation example of radial clearance after fitting

unit: mm

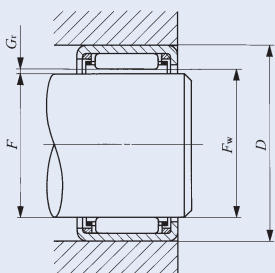
Calculation procedure	Example of TLA 2020 Z
 <p>① Dimension of roller set bore diameter of bearing after it has been press-fitted into the ring gauge. Dimension of ring gauge (<math>D_0</math>): See Tables 2.1 and 2.2 on page B4. Max. value of roller set bore dia. (<math>F_{w \max}</math>): No-go dimension of plug gauge Min. value of roller set bore dia. (<math>F_{w \min}</math>): Go dimension of plug gauge</p>	From Table 2.1 on page B4 $D_0 = 25.972$ $F_{w \max} = 20.028$ $F_{w \min} = 20.007$
<p>② Dimension of housing bore Max. value of housing bore (<math>D_{\max}</math>): See the dimension table. Min. value of housing bore (<math>D_{\min}</math>): See the dimension table.</p>	From the dimension table on page B14, $D_{\max} = 25.993$ $D_{\min} = 25.972$
<p>③ Dimension of roller set bore diameter of bearing after it has been press-fitted into the housing bore Max. value of roller set bore dia. (<math>F_{we \max}</math>) = <math>(D_{\max} - D_0) + F_{w \max}</math> Min. value of roller set bore dia. (<math>F_{we \min}</math>) = <math>(D_{\min} - D_0) + F_{w \min}</math></p>	From the equations, $F_{we \max} = 20.049$ $F_{we \min} = 20.007$
<p>④ Dimension of shaft Max. value of shaft dia. (<math>F_{\max}</math>): See the dimension table. Min. value of shaft dia. (<math>F_{\min}</math>): See the dimension table.</p>	From the dimension table on page B14, $F_{\max} = 20.000$ $F_{\min} = 19.987$
<p>⑤ Radial clearance after mounting Max. value of radial clearance (<math>G_{r \max}</math>) = <math>F_{we \max} - F_{\min}</math> Min. value of radial clearance (<math>G_{r \min}</math>) = <math>F_{we \min} - F_{\max}</math></p>	From the equations, $G_{r \max} = 0.062$ $G_{r \min} = 0.007$ The radial clearance after mounting becomes 0.007~0.062 mm.

$D$  : Housing bore diameter  
 $F_w$  : Roller set bore diameter  
 $F$  : Shaft diameter  
 $G_r$  : Radial clearance

## Lubrication

Bearings with prepacked grease are shown in Table 6. ALVANIA GREASE S2 (SHELL) is prepacked as the lubricating grease.

In the case of bearings without prepacked grease, perform proper lubrication for use. If the bearings are operated without lubrication, the wear of the roller contact surfaces will increase and the bearing life will be shortened.

## Oil Hole

For Shell Type Needle Roller Bearings with an oil hole, "OH" is appended to the end of the identification number.

Example TA 2525 Z OH

The symbol "OH" is not marked on the bearing itself, but is shown on its packaging, etc. When bearings with multiple oil holes are required, please consult IKO.

Table 6 Bearings with prepacked grease

○ : With prepacked grease × : Without prepacked grease

Series	Bearing type	Caged			Full complement
		Standard	Closed end	With seals	Grease retained
Metric series	TLA, TLAM, YTL	×	×	○	○
	TA, TAM, YT	×	×	—	○
Inch series	BA, BAM, YB	×	×	—	○
	BHA, BHAM, YBH	×	×	—	○

## Static Safety Factor

Since Shell Type Needle Roller Bearings employ an outer ring made from a thin steel plate which is drawn, carburized and quenched, excessively large loads must be avoided. The required static safety factor is usually more than 3.

## Specifications of shaft and housing

Shell Type Needle Roller Bearings are commonly used without an inner ring. In such cases, the surface hardness of the raceway surface should be 58~64HRC and the surface roughness should not exceed  $0.2 \mu mR_a$ . However, when the operating condition is not severe, a surface roughness  $0.8 \mu mR_a$  or less can be used.

If the surface hardness is low, the load rating must be corrected by the hardness factor shown on page A20. When the shaft cannot be heat treated and finished by grinding, the use of IKO Inner Rings for Shell Type Needle Roller Bearings (See page H1.) is recommended.

## Mounting

Shell Type Needle Roller Bearings should be pressed into the housings gently using the appropriate tool as shown in Fig. 1, with their marked end surface up. As the outer ring is thin, it must never be struck directly with a hammer.

Since the outer rings of Shell Type Needle Roller Bearings are firmly fitted to housing bores with interference, it is unnecessary to fix them axially. Fig. 2 shows mounting examples.

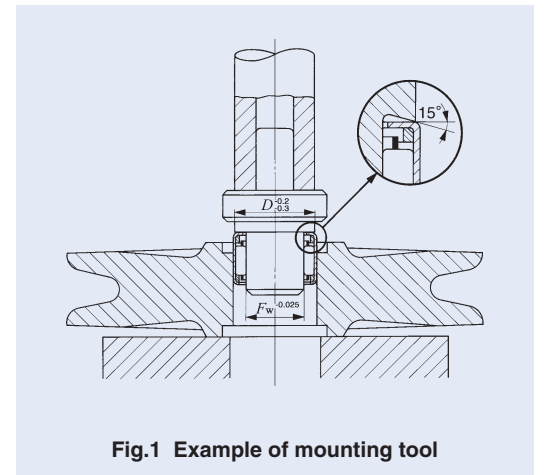

Fig.1 Example of mounting tool

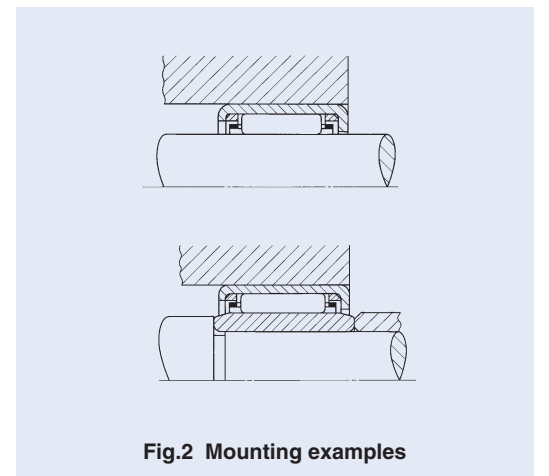
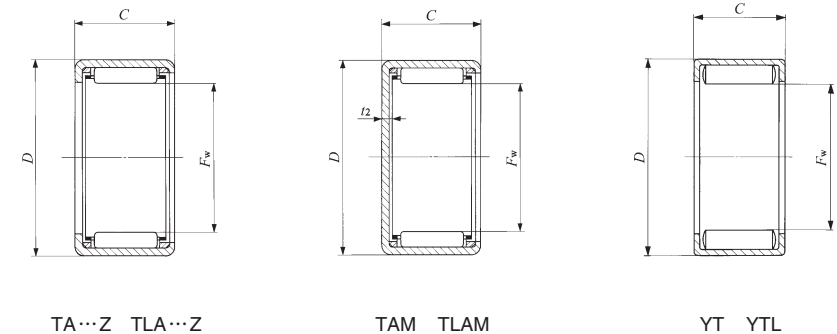

Fig.2 Mounting examples

SHELL TYPE NEEDLE ROLLER BEARINGS



Shaft dia. 4 – 10mm

Shaft dia. mm	Identification number									
	Standard	Mass (Ref.) g	Closed end	Mass (Ref.) g	Standard	Mass (Ref.) g	Closed end	Mass (Ref.) g	Grease retained	Mass (Ref.) g
4	—	—	—	—	<b>TLA 48 Z</b>	1.54	<b>TLAM 48</b>	1.67	—	—
	—	—	—	—	—	—	—	—	<b>YTL 48</b>	1.73
5	—	—	—	—	<b>TLA 59 Z</b>	1.9	<b>TLAM 59</b>	2	—	—
	—	—	—	—	—	—	—	—	<b>YTL 59</b>	2.4
6	—	—	—	—	<b>TLA 69 Z</b>	2.2	<b>TLAM 69</b>	2.3	—	—
7	—	—	—	—	<b>TLA 79 Z</b>	2.5	<b>TLAM 79</b>	2.7	—	—
8	—	—	—	—	<b>TLA 810 Z</b>	3.1	<b>TLAM 810</b>	3.3	—	—
	<b>TA 810 Z</b>	6.7	<b>TAM 810</b>	7.1	—	—	—	—	—	—
	<b>TA 815 Z</b>	9.7	<b>TAM 815</b>	10.1	—	—	—	—	—	—
	<b>TA 820 Z</b>	12.9	<b>TAM 820</b>	13.3	—	—	—	—	—	—
	—	—	—	—	—	—	—	—	<b>YT 810</b>	7.7
9	—	—	—	—	<b>TLA 910 Z</b>	3.4	<b>TLAM 910</b>	3.6	—	—
	—	—	—	—	<b>TLA 912 Z</b>	4	<b>TLAM 912</b>	4.3	—	—
	<b>TA 912 Z</b>	8.7	<b>TAM 912</b>	9.2	—	—	—	—	—	—
—	—	—	—	—	—	—	—	—	—	
—	—	—	—	—	—	—	—	—	<b>YT 912</b>	10.1
10	—	—	—	—	<b>TLA 1010 Z</b>	3.7	<b>TLAM 1010</b>	4	—	—
	—	—	—	—	<b>TLA 1012 Z</b>	4.4	<b>TLAM 1012</b>	4.8	—	—
	—	—	—	—	<b>TLA 1015 Z</b>	5.5	<b>TLAM 1015</b>	5.9	—	—
	<b>TA 1010 Z</b>	7.9	<b>TAM 1010</b>	8.5	—	—	—	—	—	—
	<b>TA 1012 Z</b>	9.3	<b>TAM 1012</b>	10	—	—	—	—	—	—
	<b>TA 1015 Z</b>	11.5	<b>TAM 1015</b>	12.2	—	—	—	—	—	—
	<b>TA 1020 Z</b>	15.4	<b>TAM 1020</b>	16	—	—	—	—	—	—

Note(1) Allowable rotational speed applies to oil lubrication. For grease lubrication, a maximum of 60% of this value is allowable.  
 Remark Shell Type Grease Retained Full Complement Needle Roller Bearings are provided with prepacked grease. Standard type and closed end type bearings are not provided with prepacked grease, so perform proper lubrication when using these types of bearings.

Boundary dimensions mm				Standard mounting dimensions mm						Basic dynamic load rating C N	Basic static load rating C <sub>0</sub> N	Allowable rotational speed <sup>(1)</sup> rpm	Assembled inner ring
F <sub>w</sub>	D	C	t <sub>2</sub> Max.	Shaft dia. h6		Housing bore dia.							
				Max.	Min.	Max.	Min.	Max.	Min.				
4	8	8	1	4.000	3.992	—	—	7.996	7.981	1 350	1 010	75 000	—
4	8	8	—	—	—	—	—	—	—	3 010	2 900	40 000	—
5	9	9	1	5.000	4.992	—	—	8.996	8.981	1 880	1 600	65 000	—
5	9	9	—	—	—	—	—	—	—	4 320	4 750	30 000	—
6	10	9	1	6.000	5.992	—	—	9.996	9.981	2 100	1 900	55 000	—
7	11	9	1	7.000	6.991	—	—	10.995	10.977	2 490	2 450	50 000	—
8	12	10	1	8.000	7.991	—	—	11.995	11.977	3 320	3 670	45 000	—
8	15	10	1.3	—	—	—	—	—	—	3 470	2 880	45 000	—
8	15	15	1.3	8.000	7.991	15.010	14.992	—	—	5 780	5 570	45 000	—
8	15	20	1.3	—	—	—	—	—	—	8 340	8 920	45 000	—
8	15	10	—	—	—	—	—	—	—	7 530	7 950	19 000	—
9	13	10	1	9.000	8.991	—	—	12.995	12.977	3 500	4 040	45 000	—
9	13	12	1	—	—	—	—	—	—	4 460	5 510	45 000	—
9	16	12	1.3	—	—	—	—	—	—	5 140	4 880	45 000	—
9	16	16	1.3	9.000	8.991	16.010	15.992	—	—	6 960	7 210	45 000	—
9	16	12	—	—	—	—	—	—	—	9 690	11 200	17 000	—
10	14	10	1	—	—	—	—	—	—	3 870	4 740	40 000	<b>IRT 710</b>
10	14	12	1	10.000	9.991	—	—	13.995	13.977	4 920	6 460	40 000	<b>IRT 712</b>
10	14	15	1	—	—	—	—	—	—	6 390	9 040	40 000	<b>IRT 715</b>
10	17	10	1.3	—	—	—	—	—	—	4 150	3 780	40 000	<b>IRT 710</b>
10	17	12	1.3	—	—	—	—	—	—	5 590	5 540	40 000	<b>IRT 712</b>
10	17	15	1.3	10.000	9.991	17.010	16.992	—	—	6 920	7 300	40 000	<b>IRT 715</b>
10	17	20	1.3	—	—	—	—	—	—	9 990	11 700	40 000	—