

# GENERADORES DE VACÍO

## VACUUM GENERATORS

MONOETAPA  
MONOSTAGE

# KAC2



### KAC2 20

### KAC2 40

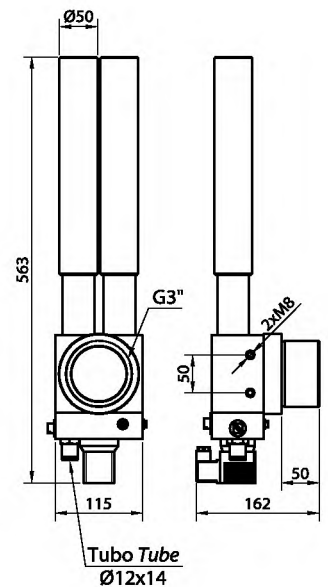
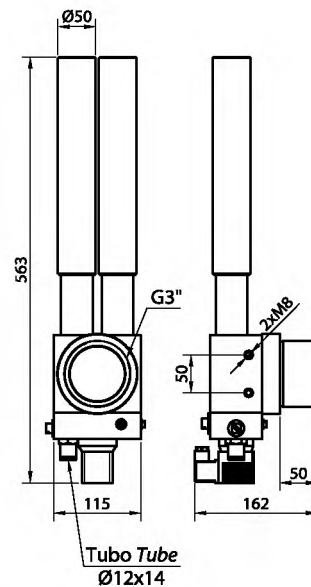

#### CARACTERÍSTICAS · CHARACTERISTICS

Depresión máx. <i>Max vacuum degree</i>	[mbar]	-200	-400
Máx. caudal aspirado <i>Max suction air flow</i>	[NI/min]	3.100	2.350
Caudal consumido <i>Air flow consumption</i>	[NI/min]	738	738
Presión de alimentación <i>Supply pressure</i>	[bar]	4 ... 8	4 ... 8
Nivel de ruido en carga <i>Working Noise level</i>	[dB]	85	85
Potencia absorbida electrov. <i>Solenoid Power cons.</i>	[W]	10 (DC) / 8 (AC)	10 (DC) / 8 (AC)
Puerto de alimentación <i>Supply port</i>		T14X12	T14X12
Puerto de vacío <i>Vacuum port</i>		G3" macho <i>G3" male</i>	G3" macho <i>G3" male</i>
Materiales <i>Materials</i>		PVC, AL, otros <i>PVC, AL, otros</i>	PVC, AL, otros <i>PVC, AL, otros</i>
Temperatura de trabajo <i>Working Temperature</i>	[°C]	-20 ... 70	-20 ... 70
Peso <i>Weight</i>	[g]	2750 ... 4560	2750 ... 4560

#### CÓMO PEDIR · HOW TO ORDER

Eyector de vacío  
*Vacuum ejector*

Eyector de vacío con expulsión al cuerpo  
*Vacuum ejector with blowing to the body*

Eyector de vacío con expulsión al racor  
*Vacuum ejector with blowing to vacuum port*

**EVKAC220 - ①**

**EVKAC240 - ①**

**EVKAC2202V - ②**

**EVKAC2402V - ②**

**EVKAC2202R - ②**

**EVKAC2402R - ②**

#### OPCIONES · OPTIONS

##### TENSIÓN PILOTAJE *PILOT VOLTAGE*

①	<b>S24A</b>	24 V CA 24 V AC
	<b>S24C</b>	24 V CC 24 V DC
	<b>S220</b>	220 V CA 220 AC
	--	Sin electroválvula <i>Without solenoid valve</i>

②	<b>S1</b>	24 V CA 24 V AC
	<b>S2</b>	24 V CC 24 V DC
	<b>S3</b>	220 V CA 220 AC

**KAC2**

**INFORMACIÓN TÉCNICA**  
TECHNICAL DATA

	[mbar]
<b>Tiempo de evacuación* [s]</b> <i>Evacuation time* [s]</i>	-100
	-200
	-300
	-400
	-500
	-600
	-700
	-800
	-900

\* Para un depósito de 100 L For 100 L tank

**KAC2 20**

0.1
0.6
--
--
--
--
--
--
--

**KAC2 40**

0.1
0.4
0.9
2
--
--
--
--
--

GENERADORES GENERATORS

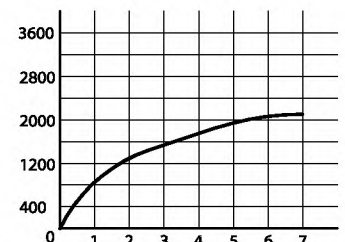
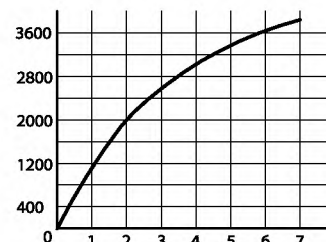
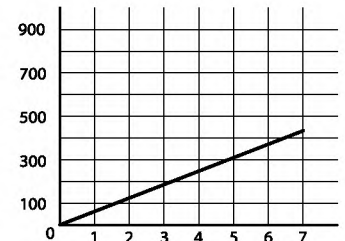
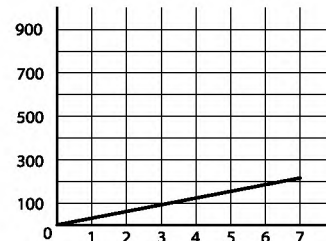
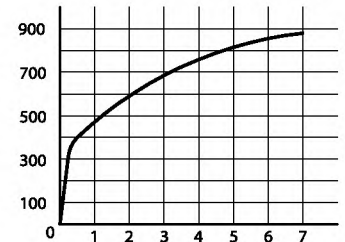
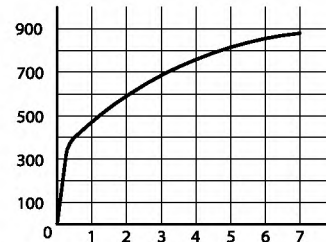
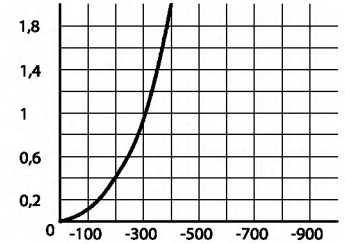
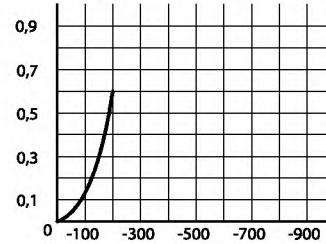
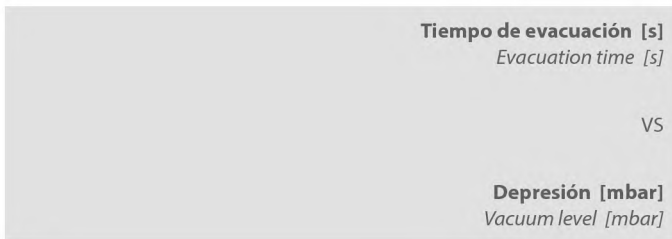
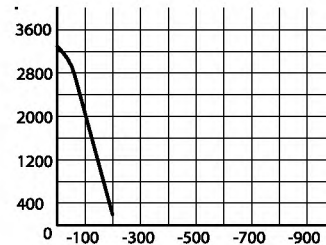

## KAC2 60

## KAC2 80

0.2

0.6

1

1.6

2.7

5

--

--

--

0.5

1.1

1.9

2.8

4

5.6

7.9

13

--

