

# SELECTION/DIMENSIONS

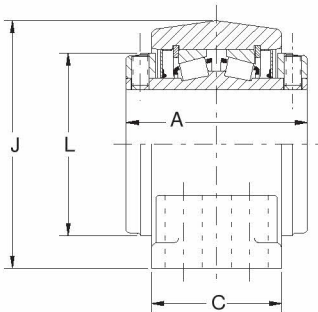

## Type E Pillow Block - Inch 4-BOLT BASE

**NOTE:** All sizes use a 1/8 - 27 NPT hydraulic grease fitting

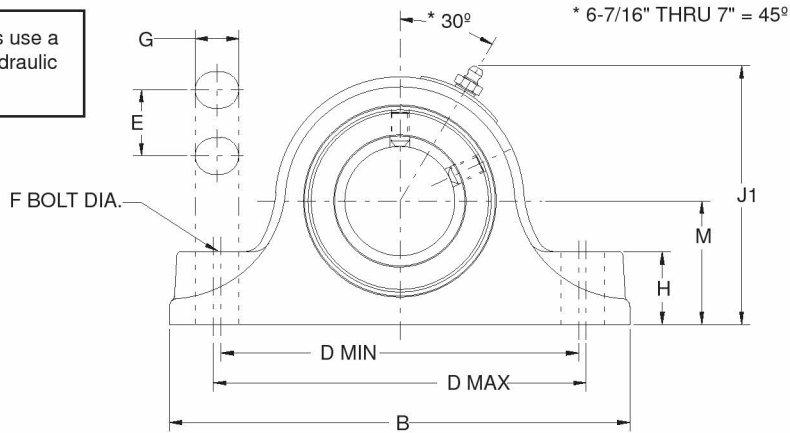

2-1/4" THRU 3" CONSTRUCTION

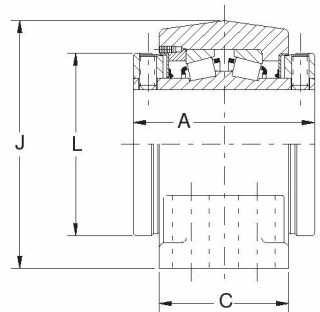

3-3/16" THRU 5" CONSTRUCTION

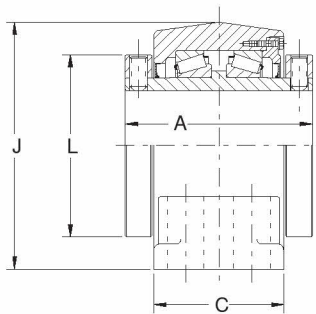

5-7/16" THRU 7" CONSTRUCTION

FEATURES/BENEFITS  
PAGE B6-2

NOMENCLATURE  
PAGE B6-4

SELECTION  
PAGE B6-5

SELECTION/DIMENSIONS  
PAGE B6-8