

# FEATURES/BENEFITS



## Type E/DOUBLE-INTERLOCK/Type K/TAF

These four product lines have many common features and benefits that are shown on this page. Unique features for each product are shown on the following pages.

The common components used by all four lines include:

- Bearings
- Seals
- Locking collars
- Bore range

### General Features:

- Factory assembled, adjusted and prelubricated
- Case hardened rollers and races
- Easy installation and maintenance
- 65 degree set screw angle Springlok collar/flingers - more holding power than 90 to 120 degree
- Single rubber lip contacting seals

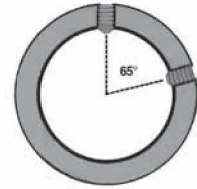
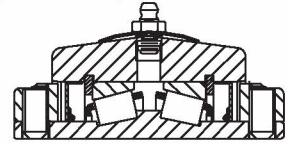

## Exclusive Sealing Designs And Features

Rolling Elements Never Exposed to Contaminants

- Exclusive "R" Seal features a combination metal shield and positive land riding contacting lip seal. Keeps contaminants out, lubricants in.
- E-TECT Seal option gives extra protection with a combination face rubbing seal in addition to the "R" Seal System (See page B6-58)
- TIMKEN™ tapered roller bearing inserts allow for combination radial and thrust loads.
- Lip design conform to cones. Permits grease to purge.
- Close fit oversized collars act as flingers for added protection in dusty or damp environments

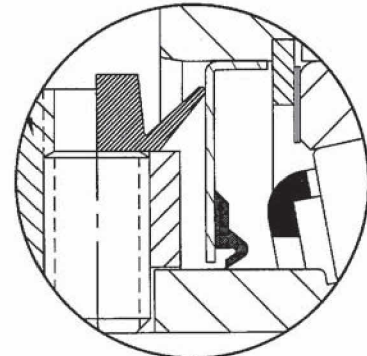
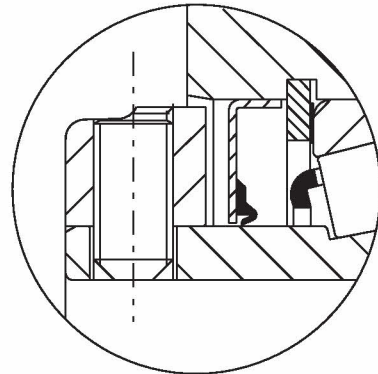



# FEATURES/BENEFITS

## TAF

### TAF IS A COST SAVING ALTERNATIVE TO SAF SPHERICAL BEARINGS

#### Mounts Fast, Stays Cleaner And Extends Service Life

- **Shaft ready** - mounts six times faster than SAF
- Interchangeable with SAF style pillow blocks
- Self-aligning, factory assembled, adjusted and lubricated
- Available in 1-7/16" up to 7" shaft diameters
- Equipped with expansion or non-expansion housing
- E-TECT seal option available up to 7"
- Optional Smart Housings accommodate speed, vibration and temperature sensor kits

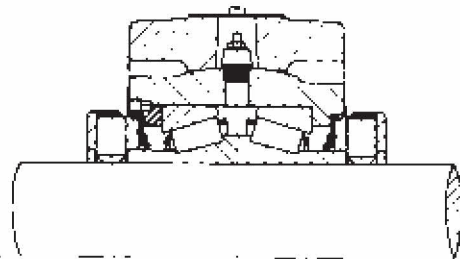

Self-aligning provided by spherically machined housing

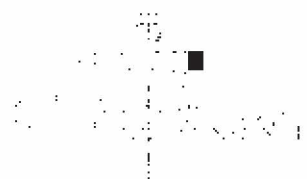
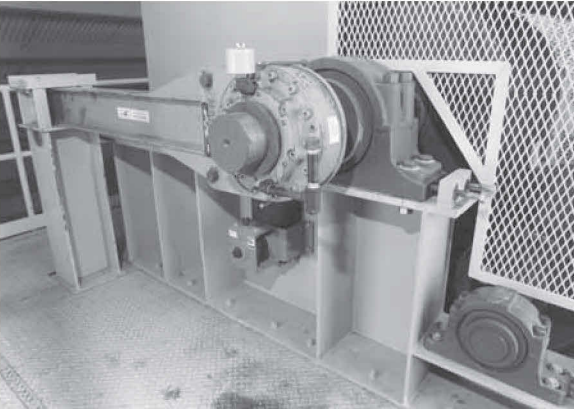

SAF

Self-aligning provided by insert, limited by seal interference

#### TAF Is Interchangeable With SAF Mounting Dimensions

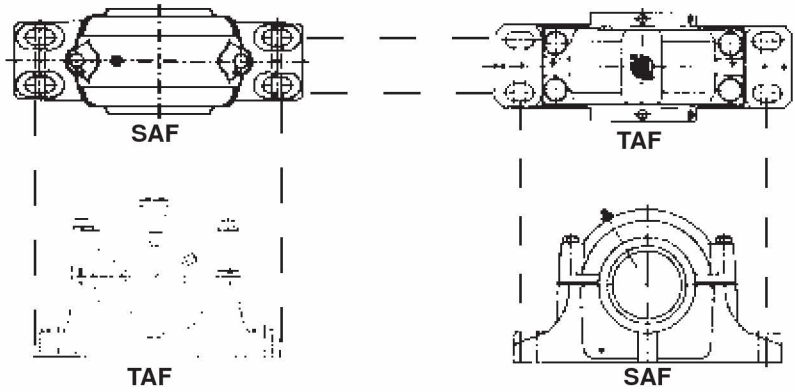

D-LOK

Type E Family

Specialty Tapered

S-2000

UNISPHERE II

# FEATURES/BENEFITS



## Type K/DOUBLE-INTERLOCK/TAF

### DODGE BEARINGS SAVE YOU TIME AND MONEY

#### Compare These DODGE TAF, Type K & DOUBLE-INTERLOCK Bearing Advantages Against Standard SAF Pillow Blocks

##### Standard SAF

- Four prices
- Up to six packages
- Open bearing
- Feeler gauge required
- Grease required

##### DODGE TAF, Type K and DOUBLE-INTERLOCK

- One price
- Sealed bearing
- Factory adjusted
- Factory lubricated
- **Shaft ready**



#### Compare Standard SAF and DODGE Sealing Designs

##### Standard SAF

- Seals ride independently of bearing
- Less than 1° static misalignment
- Sealing effectiveness decreases as misalignment increases
- Seals distort when misalignment occurs



##### DODGE TAF, Type K and DOUBLE-INTERLOCK

- Inner unit carries seal
- Up to 5° static misalignment
- Seal and bearing ride together in inner unit
- Seals maintain contact on cones even with misalignment



D-LOK

Type E Family

Speciality Tapered

S-2000

UNISPHERE II



# SPECIFICATION



## Type E, Type K, DOUBLE-INTERLOCK and TAF

Type E, Type K, DOUBLE-INTERLOCK and TAF mounted bearings are all general purpose high capacity tapered roller bearings capable of handling any combination of radial and thrust load within the capacity of the bearing.

All of these bearings are mounted to the shaft by means of set screw collars having 65 degree set screw spacing for optimum clamping force. The Type E, DOUBLE-INTERLOCK, and TAF mounted bearings have locking collars at each end of their extended inner races. Type K has a single locking collar. The tapered roller bearings for these mounted bearings all have case carburized inner races (cones), outer races (cups), and rollers.

Bearings are preassembled, prelubricated and factory adjusted. They are normally equipped with land riding contact type seals with a metal deflector guard.

The standard housing material for most of these mounted bearings is ASTM A48 Class 30 Iron having a minimum tensile strength of 30,000 psi. The outer housing for the Type K and DOUBLE-INTERLOCK flange bearings thru 4", bore size utilize housings made of ductile iron (ASTM A536 Grade 65-45-12) with 65,000 psi tensile strength. Type E pillow blocks are also available with cast steel housing having a tensile strength of 70,000 psi for 2 bolt base thru 3-1/2" bore size and 4 bolt base from 3-15/16" thru 5" bore size on an assembled or order basis.

The Type K, DOUBLE-INTERLOCK pillow blocks and flange bearings plus the TAF pillow blocks all have split outer housings used with completely assembled, lubricated and adjusted inner units simplifying replacement of the bearing in the pillow block or flange bearing. All Type E mounted bearings, Type K take up units and all D units, S-1 units, and B-1 units have solid one piece housings.

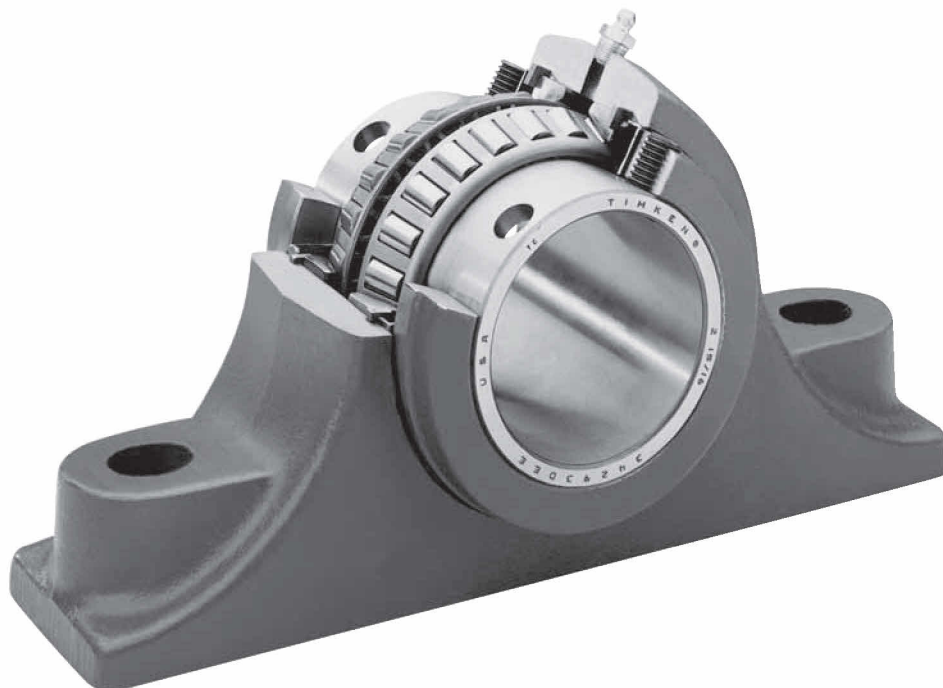

D-LOK

Type E Family

Specialty Tapered

S-2000

UNISPHERE II

FEATURES/BENEFITS PAGE B6-2	NOMENCLATURE PAGE B6-4	SELECTION PAGE B6-5	SELECTION/DIMENSIONS PAGE B6-8
--------------------------------	---------------------------	------------------------	-----------------------------------

# HOW TO ORDER



## Type E, Type K, DOUBLE-INTERLOCK and TAF

There are two ways to specify DODGE Bearings. Most of the product offering have part numbers with listings shown throughout this catalog. Use of part numbers ensures accurate order processing.

When part numbers are not shown, the product may be specified by description or part name. This method is used when ordering units that include modifications or options. To order by description, use the nomenclature key shown on page and add any special instructions to the end of the description for options not covered by the nomenclature.

### SPECIAL BEARING REQUIREMENTS AND SPECIAL LUBRICANTS

DODGE Bearings are factory adjusted and pre-lubricated. For applications where extreme ambient temperatures, high speeds or high loads are expected, a variety of specialty lubricants and adjustments are available. Standard grease provided is Mobilith AW 2 up to 5", 125mm bore. Above 5" bore Mobil Mobilux #2EP is standard. High

temperature greases available include Mobil HTS #2 and Mobilith SHC460. Other special lubricants are available upon request. Special lubricant options usually involve set-up charges and premiums. To order, specify type of lubricant required at the end of the product name or after the standard part number.

Example:

F4B-E-207 except with Mobil Grease HTS #2 grease and 012 to .015 lateral end play

or

023106 except with Mobil Grease HTS #2 grease and 012 to .015 lateral end play

### OTHER SPECIAL REQUIREMENTS NOT LISTED

For applications requiring modifications not listed, we encourage you to contact our Application Engineering Department for Bearings at 864-284-5700.

D-LOK

Type E Family

Specialty Tapered

S-2000

UNISPHERE II

FEATURES/BENEFITS PAGE B6-2	NOMENCLATURE PAGE B6-4	SELECTION PAGE B6-5	SELECTION/DIMENSIONS PAGE B6-8
--------------------------------	---------------------------	------------------------	-----------------------------------

# NOMENCLATURE



## Type E, Type K, DOUBLE-INTERLOCK and TAF

P2B - 515-TAF - 207 - RE

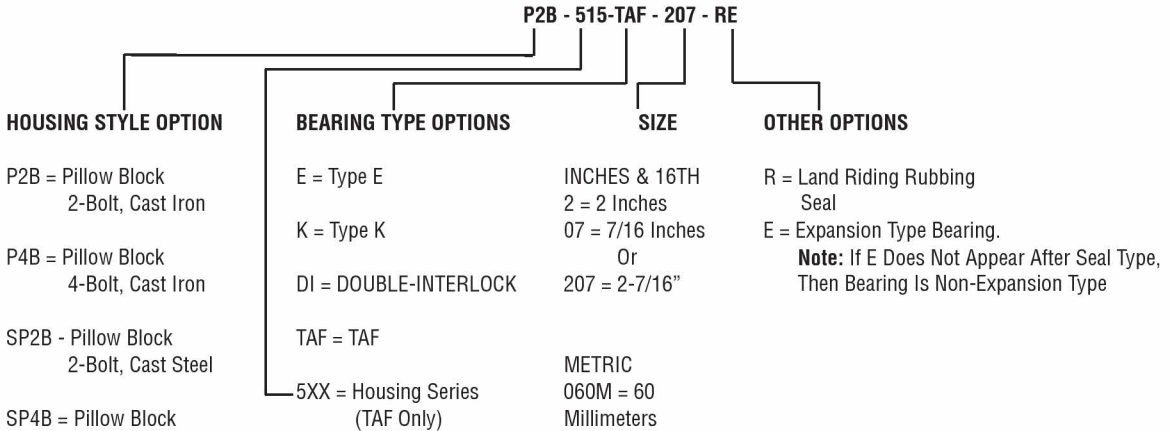

D-LOK

Type E Family

Specialty Tapered

S-2000

UNISPHERE II

FEATURES/BENEFITS PAGE B6-2	NOMENCLATURE PAGE B6-4	SELECTION PAGE B6-5	SELECTION/DIMENSIONS PAGE B6-8
--------------------------------	---------------------------	------------------------	-----------------------------------

# SELECTION



## Type E, Type K, DOUBLE-INTERLOCK and TAF Tapered Roller Bearings

DODGE Type E, K, DI and TAF Double Row Tapered Roller Bearings have the capacity to carry heavy radial loads and combined radial and thrust loads. The maximum recommended load which can be applied is limited by various components in the system such as bearing, housing, shaft, shaft attachment, speed and life requirements as listed in this catalog. DODGE tapered roller bearings have been applied successfully even when these limits have been exceeded under controlled operating conditions. Contact DODGE Application Engineering (864) 297-4800 for applications which exceed the recommendations of this catalog.

**L<sub>10</sub> Hours Life** --- The life which may be expected from at least 90% of a given group of bearings operating under identical conditions.

$$L_{10} = \left( \frac{C_{90}}{P} \right)^{10/3} \times \frac{1,500,000}{\text{RPM}}$$

Where:  $C_{90}$  = Dynamic Capacity (Table 1, pg. B6-14), lbs.

P = Equivalent Radial Load, lbs.

### GENERAL

**Heavy Service** --- For heavy shock loads, frequent shock loads, or severe vibrations, add up to 50% (according to severity of conditions) to the Equivalent Radial Load. Consult DODGE Application Engineering for additional selection assistance.

Thrust load values shown in the table below are recommended as a guide for general applications that will give adequate L<sub>10</sub> life for pillow blocks. The maximum thrust load should not exceed values shown on Table 3. Where substantial radial load is also present, it is advisable to calculate actual L<sub>10</sub> life to assure that it meets the requirements. The effectiveness of the shaft attachment to carry thrust load depends

on proper tightening of the setscrews, shaft tolerance and shaft deflections. Therefore, it is advisable to use auxiliary thrust carrying devices such as shaft shoulder, snap ring or a thrust collar to locate the bearing under thrust loads heavier than shown below, or where extreme reliability is desired.

RPM RANGE		20-200	201 - 2000	Over 2000
RECOMMENDED THRUST LOAD	E, DI, TAF	C <sub>90</sub> /4	C <sub>90</sub> /8	C <sub>90</sub> /12
	K	C <sub>90</sub> /5	C <sub>90</sub> /8	C <sub>90</sub> /12

The shaft tolerances recommended below are adequate for normal radial and radial/thrust load applications. The radial load is limited by the attachment to the shaft (see Table 1). Where the applied radial load (F<sub>r</sub>) exceeds this limit (maximum allowable slip fit radial load), a snug-to-light press fit of the shaft is required. Since the allowable load, especially at a low speed, is very large, the shaft should be checked to assure adequate shaft strength.

The magnitude and direction of both the thrust and radial load must be taken into account when selecting a housing. **When pillow blocks are utilized, heavy loads should be directed through the base. Where uplift loads are involved, see Tables 6, 7, and, pg. B6-19 for maximum values.** Where a load pulls the housing away from the mounting base, both the hold-down bolts and housing must be of adequate strength. Auxiliary load carrying devices such as shear bars are advisable for side or end loading of pillow blocks and radial load for flange units.

SHAFT SIZE	TOLERANCE, INCHES
UP TO 1-1/2"	+.0000 -.0005"
1-5/8 TO 4"	+.000 -.001"
4-7/16 TO 6"	+.000 -.0015"
6-7/16 - 8"	+.000 -.002"

**NOTE:** The L<sub>10</sub> life calculated using the above formula is subject to life adjustment factors in accordance with ABMA standards described on page B16-9.

FEATURES/BENEFITS PAGE B6-2	NOMENCLATURE PAGE B6-4	SELECTION PAGE B6-5	SELECTION/DIMENSIONS PAGE B6-8
--------------------------------	---------------------------	------------------------	-----------------------------------



# SELECTION

## Type E, Type K, DOUBLE-INTERLOCK and TAF Tapered Roller Bearings

### SELECTING BEARINGS SUPPORTING RADIAL LOADS ONLY

1. Define  $L_{10}$  Life Hours desired.
2. Establish bearing radial load,  $F_R$  ( $F_R = P$  for Pure Radial Load Conditions). The DODGE program BEST™ can be used to find application loads.
3. Establish RPM.

Using the easy selection Table 2, pg B6-15 find, under the RPM column, the equivalent radial load that equals or is higher than the application radial load for the desired life. The shaft size on the far left will be the minimum shaft size that you can use for your application. If the desired life is different than the values shown on the chart, use alternate Method A shown below.

- Example:
1.  $L_{10}$  Life = 30,000 Hours
  2. Radial load = 3800 lbs.
  3. RPM = 1,000

At the intersection of the 1,000 RPM column and the 30,000 hours  $L_{10}$  life row, the equivalent radial load of 3910 lbs. exceeds the 3800 lbs. radial load for shaft sizes 2-11/16 - 3". A bearing with bore ranging from 2-11/16" to 3" may be used for this application.

### ALTERNATE METHOD A --- SELECTING A BEARING FOR AN L10 LIFE VALUE NOT SHOWN IN THE EASY SELECTION CHART.

The  $L_{10}$  life equation can be rearranged so that the bearing dynamic capacity  $C_{90}$  is identified in terms of  $L_{10}$ , RPM and P.

$$C_{90} = \left( \frac{L_{10} \times \text{RPM}}{1,500,000} \right)^{0.3} \times P$$

( $P = F_R$  for Pure Radial Load Conditions)

Since the  $L_{10}$ , RPM, and P are known, solve for  $C_{90}$ . Select from the dynamic capacity column on Table 1, pg B6-14. The  $C_{90}$  value equal to or greater than the

$C_{90}$  value just calculated. The bore size on the far left represents the bore size selection. Check that the application RPM does not exceed the MAX. RPM on Table 1. Also check that the radial load does not exceed the Maximum Allowable Slip Fit Radial Load shown on Table 1. If it does, a line to line to light press fit of shaft is required. When selecting an  $L_{10}$  life of less than 30,000 hours, particular attention must be paid to shaft deflection and proper lubricant selection.

### SELECTING BEARINGS SUPPORTING COMBINATION RADIAL AND THRUST LOADS

When a bearing supports both a radial load and a thrust load, the loading on the two rows is shared unequally depending on the ratio of thrust to radial load. The use of the X (radial factor) and Y (thrust factor) from Table 1 converts the applied thrust load and radial loads to an equivalent radial load having the same effect on the life of the bearing as a radial load of this magnitude.

The equivalent radial load  $P = XF_R + YF_A$

Where: P= Equivalent radial load, lbs.

$F_R$ = Radial load, lbs. (see Table 1 for allowable slip fit maximum)

$F_A$ = Thrust (axial) load, lbs.

$e$  = Thrust load to radial load factor (Table 1)

X = Radial load factor (Table 1)

Y= Thrust load factor (Table 1)

To find X and Y, calculate  $F_A/F_R$  and compare to  $e$  for the selected bore size. Determine X and Y from Table 1, pg. B6-14 depending on whether  $F_A/F_R$  is equal to or less than  $e$ , or  $F_A/F_R$  is greater than  $e$ . Substitute all known values into the equivalent radial load equation. P (equivalent radial load) can be used in the life formula to determine  $L_{10}$ , or it can be compared to the allowable equivalent radial load ratings for the speed and hours life desired in the easy selection Table 2, pg B6-15.

\*The DODGE Bearing Evaluation and Selection Technique (BEST) is a menu driven computer program that calculates bearing loads, fatigue life and operating temperature for a two bearing shaft system based on user supplied input parameters. This interactive program is available at [www.ptwizard.com](http://www.ptwizard.com) under the Product Selection area.

D-LOK

Type E Family

Specialty Tapered

S-2000

UNISPHERE II

FEATURES/BENEFITS PAGE B6-2	NOMENCLATURE PAGE B6-4	SELECTION PAGE B6-5	SELECTION/DIMENSIONS PAGE B6-8
--------------------------------	---------------------------	------------------------	-----------------------------------

# SELECTION



## Type E, Type K, DOUBLE-INTERLOCK and TAF

### SELECTING BEARINGS SUPPORTING ONLY THRUST LOADS

Tapered Roller Bearings perform extremely well under pure thrust load applications. Use  $P = YFA$  for the equivalent radial load. The value of Y is obtained from Table 1, pg. B6-14 for FA/FR>e. Substitute Y and FA into the equivalent load equation. P (equivalent radial load) can be used in the life formula to determine L10 or it can be compared to the allowable equivalent radial load ratings for the speed and hours life desired in the easy selection Table 2, pg. B6-15.

### LUBRICATION

DODGE E, K, DI, and TAF tapered roller bearings up to 5" bore are lubricated at the factory with MOBILITH AW 2 grease. Above 5" bore they are lubricated with Mobil Mobilux #2EP. Mobilith AW 2 is a superior

industrial grease using a lithium complex thickener and a highly refined base oil. Mobil Mobilux #2EP grease is a superior industrial grease using a lithium hydroxystearate thickener and highly refined base oil. These greases will adequately handle low and medium speeds with low and medium loads at normal temperatures as defined on Table 5, pg. B6-18. For very low and high speeds, for heavy loads and for low and high temperatures, special greases must be used. Contact DODGE Application Engineering (864) 297-4800. DODGE engineers will recommend bearings and lubricants for the above unusual conditions. DODGE also has the expertise to custom design and build special bearings for your needs. The only maintenance requirement for DODGE Tapered Roller Bearings is periodic relubrication at regular intervals as outlined in the appropriate instruction manuals.

### RELUBRICATION SCHEDULE

Hours Run per Day	SUGGESTED LUBRICATION PERIOD IN WEEKS							
	1 to 250	251 to	501 to	751 to	1001 to	1501 to	2001 to	2501 to
	RPM	500 RPM	750 RPM	1000 RPM	1500 RPM	2000 RPM	2500 RPM	3000 RPM
8	12	12	10	7	5	4	3	2
16	12	7	5	4	2	2	2	1
24	10	5	3	2	1	1	1	1

**High Speed Operation** --- In the higher speed ranges too much grease will cause overheating. The amount of grease that the bearing will take for particular high speed application can only be determined by experience --- see "Operating Temperature" below. If excess grease in the bearing caused overheating, it will be necessary to remove grease fitting (also drain plug when furnished) to permit excess grease to escape. When establishing a relubrication schedule, note that a small amount of grease at frequent intervals is preferable to a large amount at infrequent intervals.

**Operation in Presence of Dust, Water or Corrosive Vapors** --- Under these conditions the bearing should contain as much grease as speed will permit, since a full bearing with consequent slight leakage is the best protection against entrance of foreign material. In the higher speed ranges too much grease will cause overheating --- see "High Speed Operation". In the lower speed ranges, it is advisable to add extra grease to a new bearing before putting into operation. Bearings

should be greased as often as necessary (daily if required) to maintain a slight leakage at the seals.

### INSTALLATION AND MAINTENANCE

In nearly all applications good design practice requires two bearings supporting the shaft. In cases where three or more bearings are installed, unless precautions are taken to line the bearings up, both vertically and horizontally, it is possible to induce heavy loads. In the case of two bearings, alignment is not as critical, especially with DODGE K, DI, and TAF Tapered Roller Bearings. K, DI, and TAF bearings are designed to allow as much as 2° to 7° of static misalignment depending on bore size. To ensure good alignment, mounting surfaces must be checked for flatness and must lie in the same plane. When tightening base bolts and cap bolts, each bolt should be alternately tightened in incremental torque values until full torque is achieved to prevent the angular shifting of the pillow block that occurs when one bolt is tightened to its full torque. Shimming may be required to minimize misalignment..

FEATURES/BENEFITS PAGE B6-2	NOMENCLATURE PAGE B6-4	SELECTION PAGE B6-5	SELECTION/DIMENSIONS PAGE B6-8
--------------------------------	---------------------------	------------------------	-----------------------------------

# SELECTION



## Type E, Type K, DOUBLE-INTERLOCK and TAF

**TABLE 1 - E, K, DI, AND TAF TAPERED ROLLER BEARING RADIAL AND THRUST FACTORS**

SHAFT SIZE	e	FA/FR<e		FA/FR>e		DYNAMIC CAPACITY C90	STATIC CAPACITY C0	MAXIMUM RPM	MAXIMUM RPM	MAXIMUM ALLOWABLE SLIP FIT RADIAL LOAD, FR **, LBS	
		X	Y	X	Y	LBS.	LBS.	R-SEAL	E-TECT	E, DI, & TAF	K
1-3/16 1-1/4	0.49	0.87	1.77	0.70	2.14	2,980	15,760	4,490	3,100	3,100	2,100
1-3/8 1-7/16	0.46	0.87	1.89	0.70	2.28	4,760	26,000	3,820	2,675	5,000	3,300
1-1/2 1-5/8 1-11/16	0.44	0.87	1.96	0.70	2.37	6,140	33,000	3,320	2,325	6,400	4,300
1-3/4 1-7/8 1-15/16 2	0.33	0.87	2.64	0.70	3.18	8,070	43,000	3,050	2,135	8,400	5,600
2-3/16	0.36	0.87	2.38	0.70	2.87	8,550	48,200	2,730	1,900	8,900	5,900
2-1/4 2-7/16 2-1/2	0.40	0.87	2.17	0.70	2.63	9,090	54,000	2,420	1,700	9,500	6,300
2-11/16 2-3/4 2-15/16 3	0.46	0.87	1.87	0.70	2.26	9,600	61,200	2,060	1,440	10,000	6,700
3-3/16 3-1/4 3-7/16 3-1/2	0.50	0.87	1.71	0.70	2.07	15,300	108,600	1,640	1,145	16,000	10,500
3-15/16 4	0.49	0.87	1.77	0.70	2.14	21,000	154,000	1,530	1,070	22,000	14,600
4-7/16 4-1/2	0.53	0.87	1.63	0.70	1.97	25,800	188,400	1,360	950	27,000	----
4-15/16 5	0.47	0.87	1.83	0.70	2.21	35,500	266,000	1,200	840	35,000	----
5-7/16 5-15/16 6	0.49	0.87	1.76	0.70	2.12	40,700	354,000	915	640	42,400	----
6-7/16 6-1/2 6-15/16 7	0.54	0.87	1.61	0.70	1.95	69,200	574,000	790	550	72,000	----

**Comparing Spherical To Taper Roller Bearings:** The dynamic capacity C (spherical) and C90 (taper) are not to the same base. To compare basic dynamic capacities, multiply C x .259 and compare to C90.

\*C90 - Dynamic capacity based on a rated life of 90 million revolutions or 3000 hours at 500 RPM.

\*\* If load exceeds maximum allowable slip fit radial load, (FR), line-to-line, to light press fit of shaft required. Application up to maximum slip fit radial load may be applied if recommended shaft tolerances are used.

FEATURES/BENEFITS PAGE B6-2	NOMENCLATURE PAGE B6-4	SELECTION PAGE B6-5	SELECTION/DIMENSIONS PAGE B6-8
--------------------------------	---------------------------	------------------------	-----------------------------------

# SELECTION



## Type K, DOUBLE-INTERLOCK and TAF

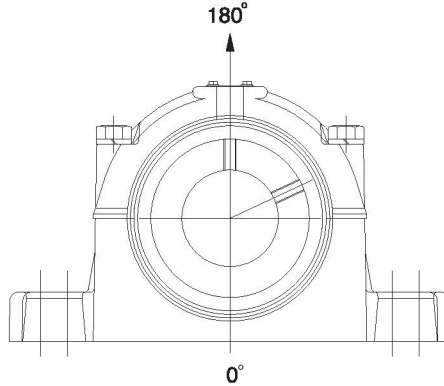

**Table 7:  
Housing Ratings  
Type K and DI Housing (Split Housing)**

SHAFT SIZE (INCHES)	MAXIMUM RECOMMENDED HOUSING CAP LOADS, LBS. 180°
1-3/16 - 1-1/4	4,300
1-3/8 - 1-7/16	5,060
1-1/2 - 1-11/16	5,940
1-3/4 - 2	8,660
2-3/16	10,100
2-1/4 - 2-1/2	10,100
2-11/16 - 3	11,220
3-3/16 - 3-1/2	16,170
3-15/16 - 4	19,580
4-7/16 - 4-1/2	20,130
4-15/16 - 5	24,530
5-7/16 - 6	35,200
6-7/16 - 7	56,000

**Table 8:  
Housing Ratings  
TAF (Split Housing)**

SHAFT SIZE (INCHES)	MAXIMUM RECOMMENDED HOUSING CAP LOADS, LBS. 180°
1-7/16	4,600
1-11/16	5,400
1-15/16	7,875
2-3/16	9,200
2-7/16 - 2-1/2	9,220
2-15/16 - 3	10,200
3-7/16 - 3-1/2	14,700
3-15/16 - 4	17,800
4-7/16 - 4-1/2	18,300
4-15/16 - 5	22,300
5-7/16 - 6	30,000
6-7/16 - 6-1/2	30,000
6-15/16 - 7	48,000

\*When utilizing heavy cap loads on pillow block housings, the installation must adhere to the following procedures.

1. The pillow block base bolts must be of **Grade 8 strength with hardened washers and properly tightened to the mounting structure.**
2. The use of stop bars (shear strips) against pillow block where side loads are encountered
3. In all cases where loads are heavy, the L10 life of the bearing should be checked for proper selection and life requirements

FEATURES/BENEFITS PAGE B6-2	NOMENCLATURE PAGE B6-4	SELECTION PAGE B6-5	SELECTION/DIMENSIONS PAGE B6-8
--------------------------------	---------------------------	------------------------	-----------------------------------