

# DIMENSION

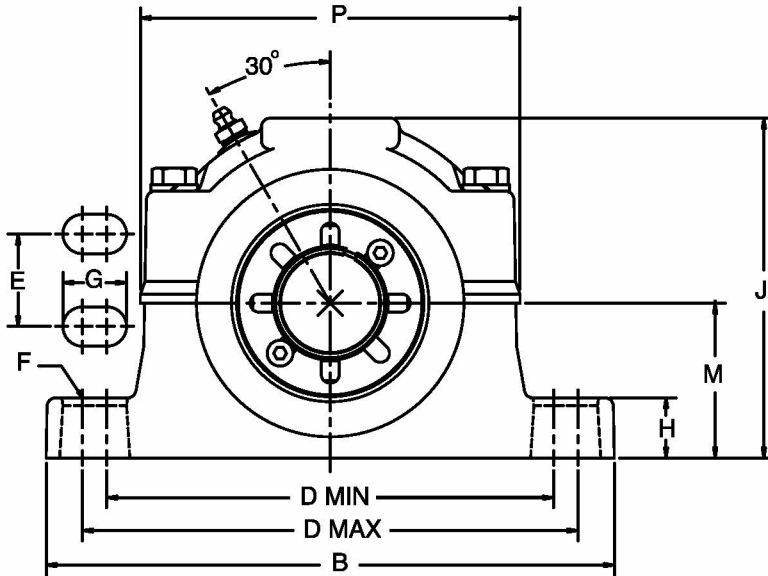

## IMPERIAL ISAF 2-7/16 THRU 7 INCH - 4-BOLT



NOTE: All sizes use a 1/8-27 NPT hydraulic grease fitting

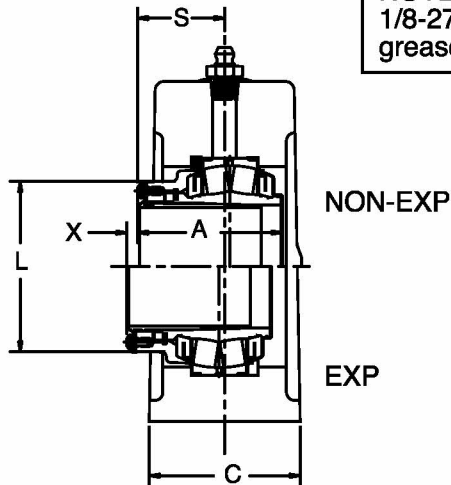

LABYRINTH SEAL

IMPERIAL FEATURES PAGE B10-3	IMPERIAL SPECIFICATION PAGE B10-6	IMPERIAL NOMENCLATURE PAGE B10-9	IMPERIAL SELECTION PAGE B10-12
---------------------------------	--------------------------------------	-------------------------------------	-----------------------------------



## IMPERIAL ISAF 2-7/16 THRU 7 INCH - 4-BOLT

Shaft Size	SAF Series	A	B	C	D		E	F Bolts	G
					Min	Max			
2-7/16	<b>515</b>	3-27/64	11-1/8	3-1/8	8-5/8	9-5/8	1-7/8	1/2	1-1/8
2-11/16	<b>516</b>	3-1/2	12-19/32	3-1/2	9-7/8	11	2-1/8	5/8	1-5/16
2-15/16	<b>517</b>	3-1/2	12-19/32	3-1/2	9-7/8	11	2-1/8	5/8	1-5/16
3-7/16	<b>520</b>	4-5/32	15-23/64	4-11/32	11-13/16	13-1/8	2-3/8	3/4	1-5/8
3-15/16	<b>522</b>	4-45/64	16-1/2	4-3/4	12-19/32	14-1/2	2-3/4	3/4	1-53/64
4-7/16	<b>526</b>	5-15/64	18-3/8	5-1/8	14-1/2	16	3-1/4	7/8	1-3/4
4-15/16	<b>528</b>	5-63/64	19-45/64	5-7/8	15-5/8	17-3/8	3-3/8	1	2
5-7/16 5-1/2	<b>532</b>	6-11/64	21-21/32	6-1/4	17-3/8	19-1/4	3-3/4	1	2-1/16
5-15/16 6	<b>534</b>	7-5/64	24-3/4	6-3/4	19-3/8	21-5/8	4-1/4	1	2-1/4
6-7/16 6-1/2	<b>536</b>	7-25/64	26-3/4	7-1/8	20-7/8	23-5/8	4-5/8	1	2-1/2
6-15/16 7	<b>538</b>	7-25/64	28	7-1/2	21-5/8	24-3/8	4-1/2	1-1/4	2-3/4

Shaft Size	SAF Series	H	J	L	M	P	S	X Expansion
2-7/16	<b>515</b>	1-1/4	6-55/64	3-7/8	3-1/4	7-27/64	2-1/16	5/16
2-11/16	<b>516</b>	1	7-1/2	4-9/32	3-1/2	8-5/16	2-5/32	15/64
2-15/16	<b>517</b>	1-1/4	7-3/4	4-9/32	3-3/4	8-5/16	2-5/32	15/64
3-7/16	<b>520</b>	1-21/32	9-1/4	5	4-1/2	10-1/8	2-31/64	3/8
3-15/16	<b>522</b>	1-25/32	10-3/16	5-9/16	4-15/16	10-23/32	2-55/64	3/8
4-7/16	<b>526</b>	2-1/16	11-21/32	6-7/16	6	12-15/32	3-3/32	3/8
4-15/16	<b>528</b>	2-1/16	12-13/32	7-5/8	6	13-3/8	3-11/16	3/8
5-7/16 5-1/2	<b>532</b>	2-11/32	12-1/2	8-3/4	6-11/16	13-3/8	3-41/64	3/8
5-15/16 6	<b>534</b>	2-7/8	13-11/16	10-1/4	7-1/16	15-3/32	4-7/64	3/8
6-7/16 6-1/2	<b>536</b>	3	15-1/8	11-13/32	7-1/2	17-3/8	4-11/32	3/8
6-15/16 7	<b>538</b>	3-1/8	15-1/2	11-13/32	7-7/8	17-3/8	4-11/32	3/8

See page B10-63 for part number

IMPERIAL FEATURES PAGE B10-3	IMPERIAL SPECIFICATION PAGE B10-6	IMPERIAL NOMENCLATURE PAGE B10-9	IMPERIAL SELECTION PAGE B10-12
---------------------------------	--------------------------------------	-------------------------------------	-----------------------------------