



Gear racks

Gear rack drives main feature is their high level of efficiency. They are the best choice for high axial forces.

This drive rigidity is constant over the whole length.

They are also very cost effective for long strokes of more than 2m.

With a rack and pinion system a slideway is driven by the pinion running on a fixed gear rack.

There is a basic difference between straight and helical toothed gear racks.

Apart from typical dimensions, SCHNEEBERGER offers any cross sections with metric or module pitches. The max. one-piece length is 3000 mm. Joining with butt joints is possible for longer lengths.

The tooth rack can be milled or ground depending on the customer's requirements. A particular feature is that different materials and hardening processes can be used. Depending on the load to be applied you have a choice of soft, induction or case hardened or nitride hardened gear racks.

Skill and expertise are our strengths.

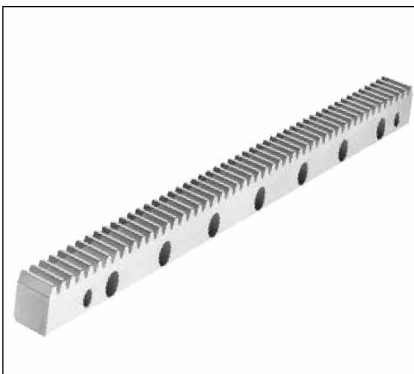

Standard gear racks

Straight and helical toothed gear racks are available in typical industrial dimensions from module 2 to module 12. Different materials, hardnesses and accuracy are available depending on the load to be applied.



Customised gear racks

You need a gear rack but standardised dimensions do not fit your system?

No problem.

You can have any gear racks up to module 20. The maximum one-piece length is 3000 mm.

The customer can choose from different materials and therefore configure the gear rack just as required.

Special is our standard.

1.2 Overview

Properties of the gear racks/ conversion

Modular tooth pitch (-M)

Tooth rack	Material condition	Material	Modules	max. length for following qualities				
				Q5	Q6	Q8	Q9	Q11
helical (-S-)	soft (-W-)	C45, 42CrMo4V, 16MnCr5	2 ... 20	1000	3000	3000		
	induction hardened (-I-)	C45, 16MnCr5	2 ... 16	1000	2000			
			2 ... 4				3000	
	case hardened (-C-)	16MnCr5	2 ... 16	1000				
			2 ... 4		1500			
			5 ... 16		2000			
nitrided (-N-)	42CrMo4V, 16MnCr5	2 ... 16				2000		
through hardened (-H-)	X90CrMoV18	2 ... 5	1000	1000				
straight (-G-)	soft (-W-)	C45, 42CrMo4V, 16MnCr5	2 ... 20	1018	3000	3000		
	induction hardened (-I-)	C45, 16MnCr5	2 ... 16	1018	2035			
			2 ... 4				3000	
	case hardened (-C-)	16MnCr5	2 ... 16	1018				
			2 ... 4		1522			
			5 ... 16		2035			
nitrided (-N-)	42CrMo4V, 16MnCr5	2 ... 16				2035		
through hardened (-H-)	X90CrMoV18	2 ... 5	1018	1018				

Metric tooth pitch (-T)

Tooth rack	Material condition	Material	Pitch	max. length for following qualities				
				Q5	Q6	Q8	Q9	Q11
straight (-G-)	soft (-W-)	C45, 42CrMo4V, 16MnCr5	5 ... 20	1018	3000	3000		
	induction hardened (-I-)	C45, 16MnCr5	5 ... 20	1018	2035			
			5 ... 10				3000	
	case hardened (-C-)	16MnCr5	5 ... 20	1018				
			5 ... 12,5		1522			
			15 ... 20		2035			
nitrided (-N-)	42CrMo4V, 16MnCr5	5 ... 20				2035		
through hardened (-H-)	X90CrMoV18	5 ... 15	1018	1018				

Cross reference of material designations

Germany		Japan	USA	China	Special properties
W.-nr.	DIN	JIS	AIS/SAE	GB	
1.0503	C45	-	1045	45	
1.7131	16MnCr5	-	5115	18CrMn	can be welded
1.1225	42CrMo4V	SCM 440 (H)	4140	42CrMo	
1.4112	X90CrM oV18	SUS 440B	440B	9Cr18 oV	Stainless steel

1.3 Overview

Conversion/ hardness/ strength

Converting a module m into a pitch p (straight toothed) and front pitch ps for helical tooth racks

Module m	2	3	4	5	6	8	10	12	16	20
Pitch p (mm)	6,28	9,42	12,57	15,71	18,85	25,13	31,42	37,70	50,27	62,83
End pitch (ps1)(mm)	6,67	10,00	13,33	16,67	20,00	26,67	33,33	40,00	53,33	66,67

¹⁾ where $b=19.5283^\circ$

Converting pitch p (straight toothed) into a module m

Pitch p (mm)	5.00	7.50	10.00	12.50	15.00	20.00
Module m	1.59	2.39	3.18	3.98	4.77	6.37

p Pitch in mm
 p_s End pitch in mm
 m Module

b Helix angle
 $p=m \cdot \pi$
 $p=m \cdot \pi / \cos \beta$

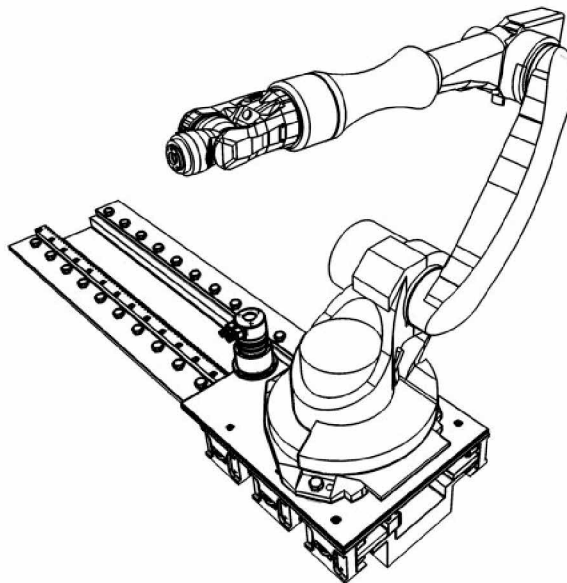

Hardness/ strength of tooth rack

Condition of teeth	Material	Tensile strength R_m N/mm ²	Hardness	
			HRc	HV1
soft	C45	~650		
tempered	42CrMo4V	max. 1000		
induction hardened	C45		55 ... 60	
	16MnCr5		60 ^{±2}	
case hardened	16MnCr5		58 ^{±3}	
nitrided	42CrMo4V, 16MnCr5			550..700
through hardened	X90CrMoV18		56 ^{±2}	

2.7 Technical principles

Customised gear racks

Any gear racks and guide racks can be made to a customer's drawing as long as they are within the specifications listed below.

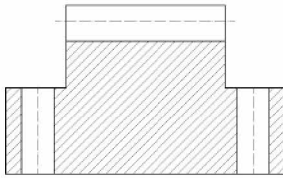

Unit weight:	max. 500 kg
Length:	max. 3000 mm
Tooth rack:	Modules 2 ... 20 Metric 5 mm ... 20 mm
Helix angle β	-30° ... +30° Left and right ascending
Material:	C45, 42CrMo4V, 16MnCr5 X90CrMoV18 (stainless steel)
Hardening process:	Induction hardening Case hardening Through hardening Nitriding
Best accuracy:	Q4

Space-saving combination for guide and drive component.

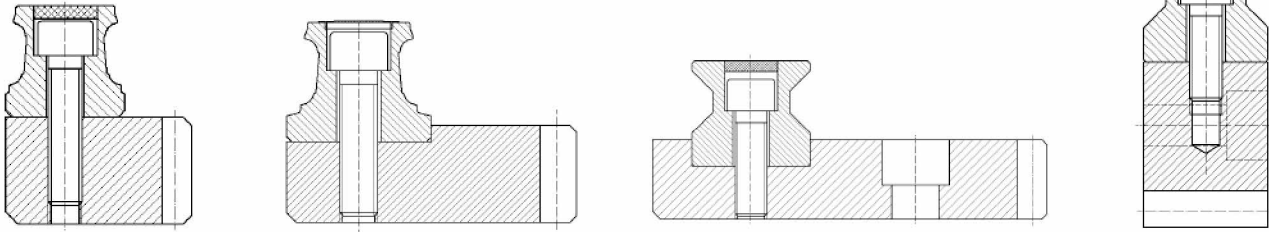

Gear rack and prismatic guide combined

Gear rack integrated into linear bearing (guide rack)

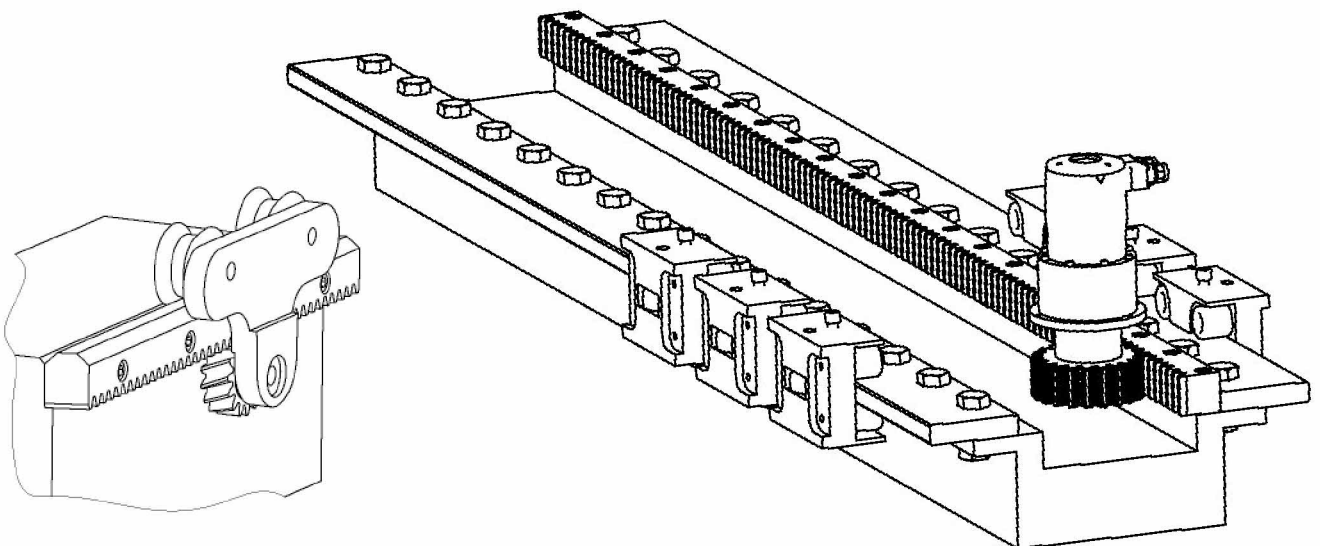

3.1 Installation

Gear rack fitting instructions / lubrication

Gear racks can be assembled in any lengths.

When assembling the spacing between two gear racks must be pitch precise.

Dowels may be needed for gear racks shorter than 1m.

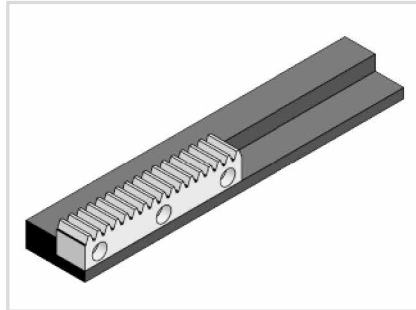

- Aligning the first gear rack
- Tighten the screws with a torque wrench.
- The torque depends on the friction condition and strength class of the screws.
- For soft or induction hardened gear racks use screws with a strength class of 10.9. For case and through hardened gear racks use strength class 12.9.

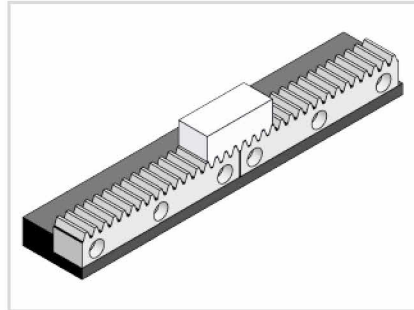

- Align the next gear rack with a mounting plate.
- Screw the gear rack on.

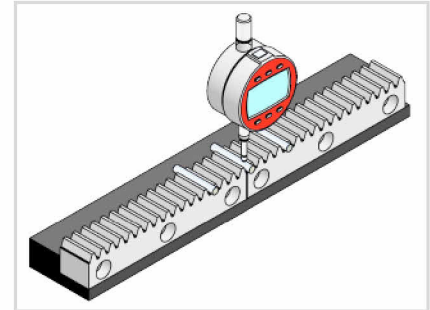

- Using a measuring roller check the height deviation at the transition point and if necessary change the position of one gear rack.
- Check that the gear racks are parallel to each other.
- Finally, insert the pins if necessary.

Lubrication - instructions for use

Adequate lubrication using a lubricant adapted to the operating conditions is required to maintain the functionality of the rack drive. Lubrication protects from wear and corrosion and reduces friction.

Apart from the initial lubrication during assembly, the machine must be lubricated regularly during operation.

Normally electrically-driven lubrication cartridges are used for lubrication. Lubrication greases NLGI 00 to NLGI 0 are applied to the drive pinion or the gear rack with a felt pinion.

A typical lubricant is Klüber Microlube GB 0.

Too little lubrication shortens the service life of the drive system. Therefore, always ensure that the machine is lubricated adequately.

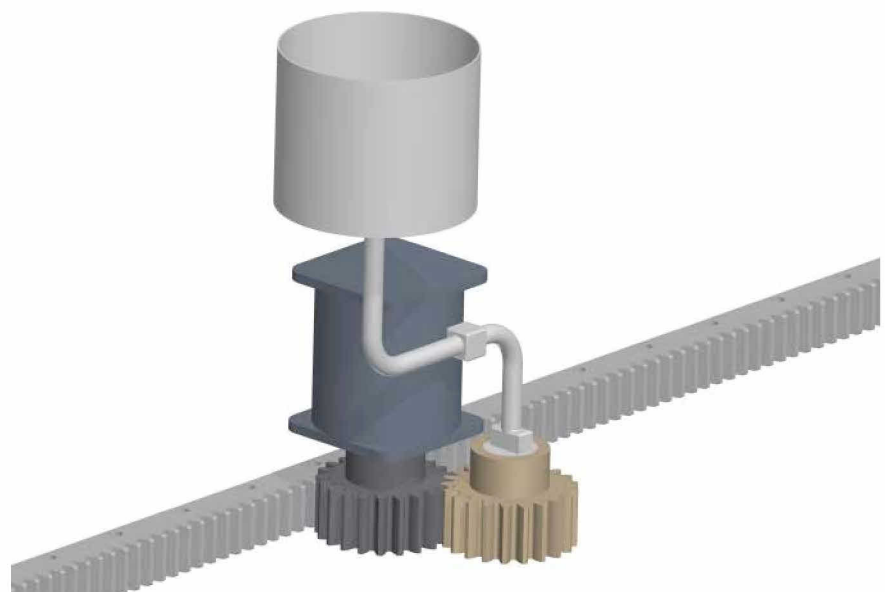

4.1 Order description

Standard gear racks

Standard gear racks			__	ZST	M6	- 59x49x1000	-S	-I	-6	-D
Quantity										
Model	ZST									
Tooth rack	M __	modular								
	T __	metric, in mm								
Size	b x h _k x L ₁ in mm									
Tooth rack	S	inclined to the right, 19.5283°								
	G	straight								
Hardness	C	Material 16MnCr5, case hardened								
	H	Material X90CrMoV18 (stainless steel), through hardened								
	I	Material C45, induction hardened								
	N	Material 42CrMo4V, nitrided								
	V	Material 42CrMo4V, tempered								
	W	Material C45, soft								
Accuracy	5	ground								
	6	ground								
	8	milled, soft								
	9	nitrided								
	11	milled, induction hardened								
Drilled holes	D	with pin and fixing holes				Fig. 1				
	OP	without pin holes				Fig. 2				
	OH	without holes				Fig. 3				

Standard assembly tool			__	MST	M6	- 59x49x207	-SL
Quantity							
Model	MST						
Tooth rack	M __	modular					
	T __	metric, in mm					
Grösse	b x h _k x L ₁ in mm						
Tooth rack	SL	inclined to the left, 19.5283°					
	G	straight					

4.1 Order description

Customised gear racks

Customised gear racks			___	ZST	M4	-60x50x1820	-SL	-C	-5	-DX	-sp
Quantity											
Model	ZST										
Tooth rack	M ___	modular									
	T ___	metric, in mm									
Size	b x h _k x L ₁	in mm									
Tooth rack	S	inclined to the right									
	SL	inclined to the left									
	G	straight									
Hardness	C	Material 16MnCr5, case hardened									
	H	Material X90CrMoV18 (stainless steel), through hardened									
	I	Material C45, induction hardened									
	J	Material 16MnCr5, induction hardened									
	N	Material 42CrMo4V, nitrided									
	O	Material 16 MnCr5, nitrided									
	S	Special material									
	V	Material 42CrMo4 V, tempered									
W	Material C45, soft										
Accuracy	5	ground									
	6	ground									
	8	milled, soft									
	9	nitrided									
	11	milled, induction hardened									
Drilled holes	D	with pin and fixing holes	Fig. 1								
	OP	without pin holes	Fig. 2								
	OH	without holes	Fig. 3								
	_X	half hole pitch ($l_x = \frac{1}{2} \cdot l$)									
Special features	sp	with special features as in the drawing									

Customised assembly tool			___	MST	M4	-60x50x200	-SR	-sp
Quantity								
Model	MST							
Tooth rack	M ___	modular						
	T ___	metric, in mm						
Size	b x h _k x L ₁	in mm						
Tooth rack	SL	inclined to the left						
	SR	inclined to the right						
	G	straight						
Special features	sp	with special features as in the drawing						