

Mecanocaucho® Soportes CB

APLICACIONES

- Mop. o Maquinaria Agrícola, en cabinas, motores, radiadores, transmisiones, cuadros eléctricos.
- Equipos auxiliares Marinos.
- Grupos electrógenos y compresores, móviles.
- Soportes entre bancadas y carrocerías, vehículos militares, autobuses, camiones, autocaravanas.

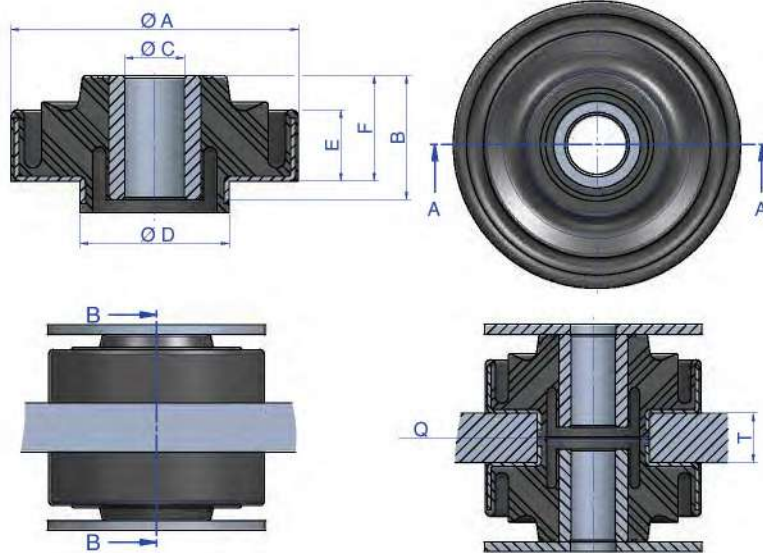

CURVAS DE CARGA FLECHA AMC
AMC-MECANOCAUCHO® TIPO CB

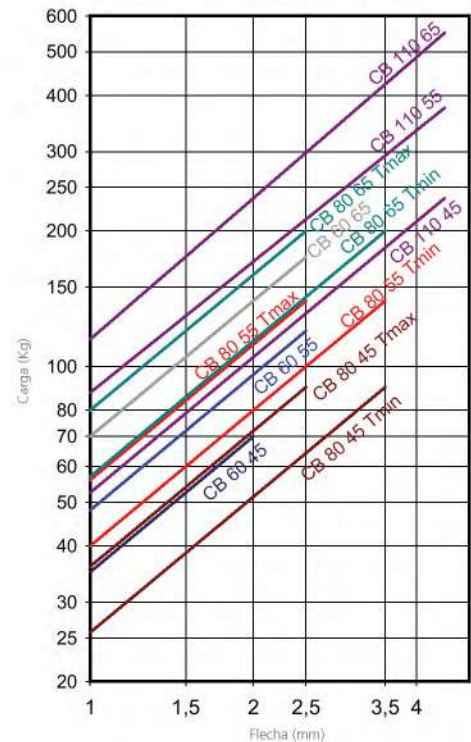

Tipo	A (mm)	B (mm)	C (mm)	D (mm)	E (mm)	F (mm)	Q (mm)	T (Máx.)	T (Min.)	Peso (gr.)	ARANDELA	Dureza	Carga máx (kg)	Código
CB 60	66	34,5	16,5	39,5	16	28	40	20	20	140	606130	45 Sh	70	156011
												55 Sh	120	156013
												65 Sh	170	156014
CB 65	65,5	38	18,9	40,5	19	29	41	20	20	175	706004	45 Sh	70	156031
												55 Sh	120	156032
												65 Sh	170	156033
CB 80	78,5	37	16,5	37,5	18	32,5	38	20	18	242	608074	45 Sh	90	156001
												55 Sh	140	156002
												65 Sh	200	156003
CB 110	109	47	22,5	56,5	27,5	40	57	25	25	630	610192	45 Sh	235	156021
												55 Sh	375	156022
												65 Sh	550	156023

Las arandelas se suministran bajo demanda, según E-Catalog.

Tipo	Peso (gr.)	Øext (mm)	Øint (mm)	ESPESOR (mm)	Código
ARANDELA CB 60	125	66	16,5	5	606130
ARANDELA CB 65	141	67	18,5	5	706004
ARANDELA CB 80	175	76	16,5	5	608074
ARANDELA CB 110	286	110	23	5	610192