

Mecanocaucho® Tipo SCB

APLICACIONES

Los soportes elásticos SCB son elementos que trabajan a compresión ya que por su diseño y montaje consiguen un efecto anti-rebote permitiendo realizar montajes de seguridad.

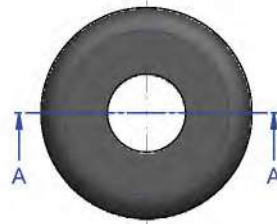
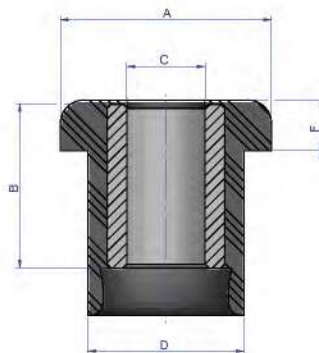
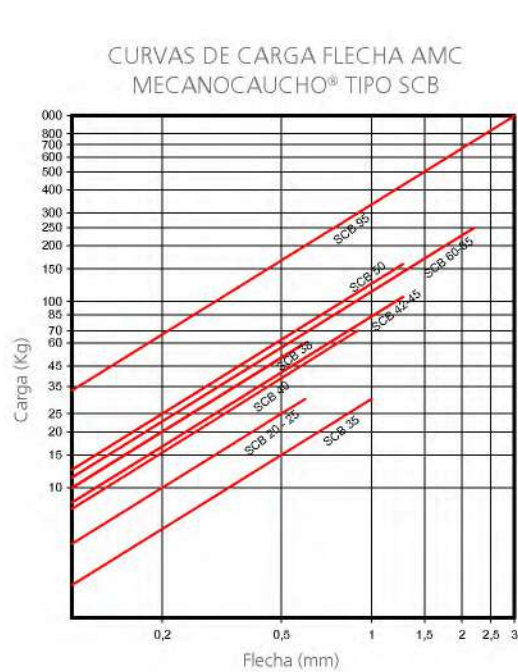

MONTAJE

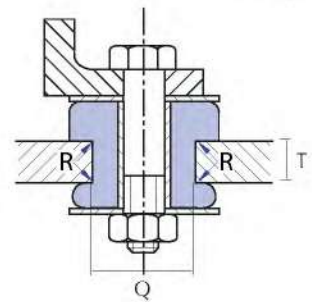

Las arandelas se suministran bajo demanda, según E-Catalog.

Tipo	A (mm)	B (mm)	C (mm)	D (mm)	F (mm)	Q (mm)	T (Max.) (mm)	T (Mín.) (mm)	Peso (gr.)	R (mm)	Carga (kg)	Dureza	Código	EAN	Tipo	Øext (mm)	Øint (mm)	ESPE-SOR (mm)	Peso (kg)	Código
SCB 20	27	15,5	10,25	20	7	19,5	5	4	20	1	30	45 Sh	138013		ARANDELA SCB 20	28	10,5	2	0,03	606185
											38	60 Sh	138019		ARANDELA SCB 20i	28	8,5	2	0,03	606124
SCB 20i	27	15,5	8	20	7	19,5	5	4	20	1	38	60 Sh	138056		ARANDELA SCB 25	28	10,5	2	0,03	606185
SCB 25	27,5	21	10	20	6,5	19,5	15	14	20	1	50	60 Sh	138001	8435282006259	ARANDELA SCB 35	28	8,5	2	0,03	606124
SCB 35	27,5	12,5	8	19,4	8,5	19	4	3	30	0,5	25	45 Sh	138012		ARANDELA SCB 38	38	12,5	3	0,04	611065
											50	60 Sh	138043		ARANDELA SCB 40	38	12,5	3	0,04	611065
SCB 38	33,5	19	10,5	20,5	11	20,5	5	3	30	0,5	80	75 Sh	138044		ARANDELA SCB 45	54	12,5	3	0,051	611080
											50	60 Sh	138022		ARANDELA SCB 50	54	12,5	3	0,051	611080
SCB 40	35	15,5	13	26,5	8	26,5	5	4	50	1	75	60 Sh	138022		ARANDELA SCB 60	66	16,5	5	0,125	606130
SCB 45	41,5	25,8	13,5	31	10	30	11	10	56	1,5	100	60 Sh	138002	8435282006266	ARANDELA SCB 65	66	16,5	5	0,125	606130
SCB 50	49,5	35	13,5	34	13,5	33	17	16	73	1,5	200	60 Sh	138003	8435282006273	ARANDELA SCB 95	95	22	6	0,31	608101
SCB 60	63	31,2	16,2	41	17	40	10	9	108	3	250	60 Sh	138004	8435282006280						
SCB 65	62	43,5	16,5	40	17	39	20	19	140	3	250	60 Sh	138005	8435282006297						
SCB 95	92	51,5	20,5	56	26,5	54,5	20	19	395	3	1000	65 Sh	138011	8435282006303						