

FLOW CHART SIZE 3

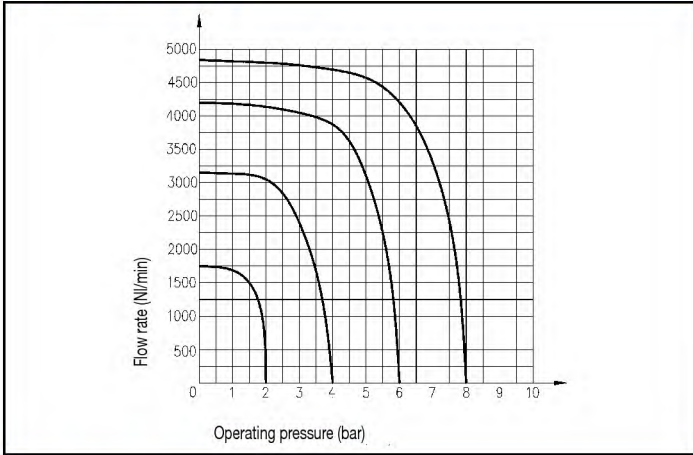

PILOTING CHART SIZE 3

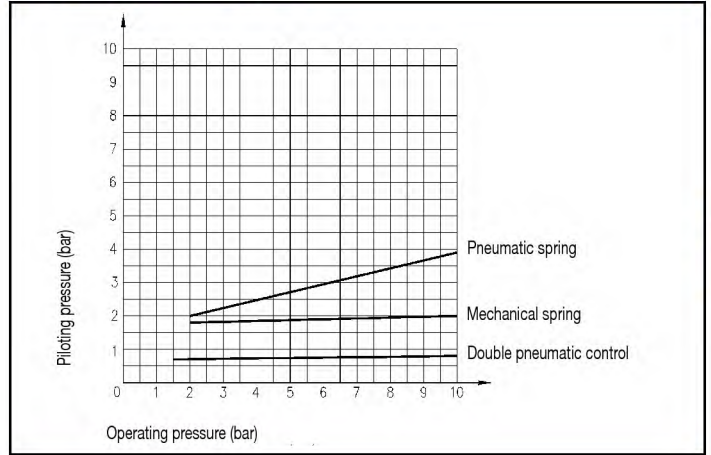

PILOT ACTUATED VALVES SIZE 1

Symbol	Function	Controls		Response times at 6 bar (ms)		Flow rate at 6 bar $\Delta P = 1$ bar (l/min)	Weight (g)	TYPE
		Actuation	Return	Energized	De-energized			
	5/2 monostable	Pneumatic	Mechanical spring	20	30	960	230	UDS 105 KR/ZR
		Pneumatic	Pneumatic spring	20	14	960	230	UDS 105 KR/TQ
	5/2 bistable	Pneumatic	Pneumatic	15	15	960	230	UDS 105 KR/KR
	5/2 bistable with override on body valve	Pneumatic	Pneumatic	15	15	960	250	UDS 105 KRP/KRP
	5/2 bistable	Pneumatic	Pneumatic differential	15	20	960	230	UDS 105 KR/TR
	5/3 closed centre	Pneumatic	Mechanical spring	20	25	580	275	UDS 105 SR/SR
	5/3 open centre	Pneumatic	Mechanical spring	20	25	800	275	UDS 105 AR/AR
	5/3 pressure centre	Pneumatic	Mechanical spring	20	25	1100	275	UDS 105 PR/PR

5 PORT SIZE 1

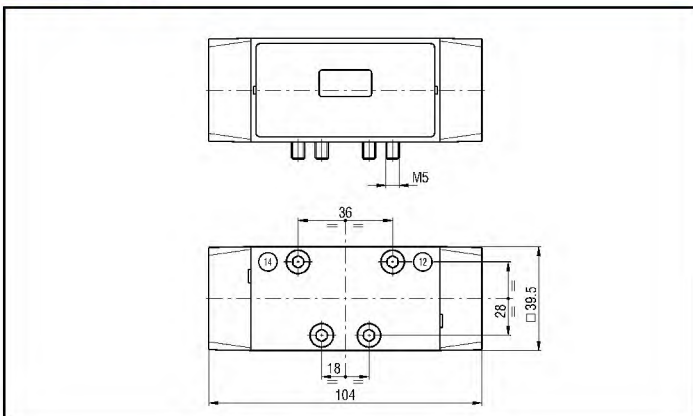

5 PORT SIZE 1 WITH MANUAL OVERRIDE ON BODY VALVE

