

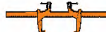







# CARVER CLAMP SERIES

## Product Overview

### Bar-Style

	Model	Holding Capacity max	Page MC-CVR-#
	<b>T186-24</b> <b>T186-36</b>	[2500 lbf] 11300N	3-4
	<b>T321-24</b> <b>T321-36</b> <b>T321-60</b>	[1500 lbf] 5650N	
	<b>T290-36</b> <b>T290-60</b> <b>T290-84</b>	[4000 lbf] 18000N	
	<b>T285-36</b> <b>T285-60</b> <b>T285-84</b>	[2000 lbf] 9000N	
	<b>T257-84</b>	[6000 lbf] 27000N	

### C-Style

	Model	Holding Capacity max	Page MC-CVR-#
	<b>T186-6</b> <b>T186-12</b> <b>T186-20</b>	[2500 lbf] 11300N	5-6
	<b>T321-10</b>	[1270 lbf] 5650N	
	<b>T290-9</b> <b>T290-18</b> <b>T290-40</b>	[4000 lbf] 18000N	
	<b>T285-9</b> <b>T285-18</b>	[2000 lbf] 9000N	
	<b>T257-24</b> <b>T257-36</b>	[6000 lbf] 27000N	

## Typical Applications

### Bar Clamps

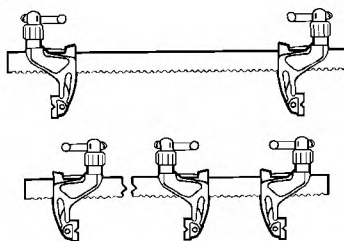

### "C" Clamps

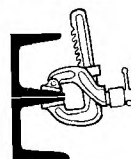

No obstruction from long screw. Ideal for structural steel fabrication.

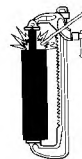

Unaffected by weld spatter. Screw is shielded and out of work area.

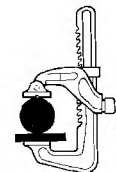

Holds rounds to flats. Limited movement of moveable jaw pad and grooved face ensure positive grip on round objects.

# BAR-STYLE SERIES

## CARVER Clamps | Dimensions

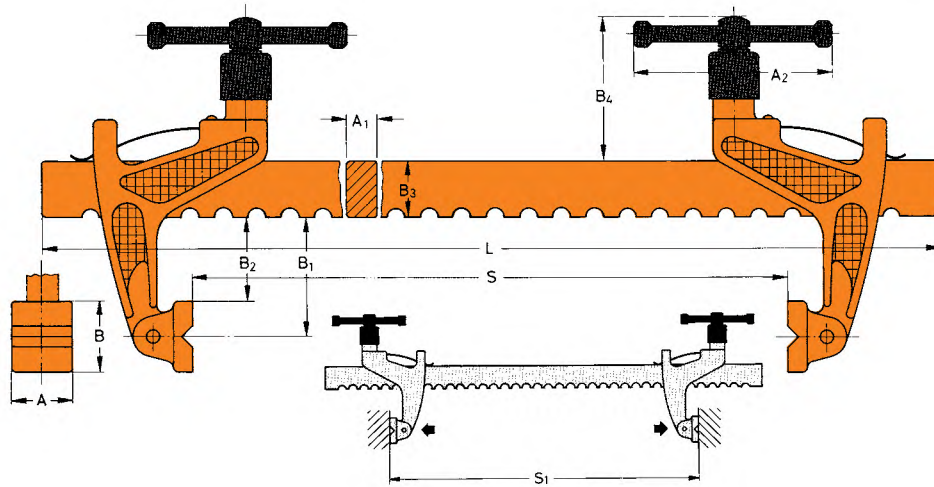

Model	[inch] mm							
	A	A1	A2	B	B2	B3	B4	L
T186-24								[28] 710
T186-36	[0.98] 25	[0.47] 12	[2.99] 76	[1.26] 32	[1.73] 44	[1.18] 30	[2.99] 76	[40.2] 1020
T321-24								[28] 710
T321-36	[0.98] 25	[0.47] 12	[2.99] 76	[1.26] 32	[4.09] 104	[1.18] 30	[2.99] 76	[40.2] 1020
T321-60								[64] 1625
T290-36								[42.1] 1070
① T290-60	[1.50] 38	[0.79] 20	[5.51] 140	[2.00] 51	[2.56] 65	[1.57] 40	[4.13] 105	[66.5] 1690
① T290-84								[90.2] 2290
T285-36								[42.1] 1070
① T285-60	[1.50] 38	[0.79] 20	[5.51] 140	[2.00] 51	[7.09] 180	[1.57] 40	[4.13] 105	[66.5] 1690
① T285-84								[90.2] 2290
① T257-84	[2.00] 51	[0.87] 22	[7.36] 187	[2.50] 63,5	[3.27] 83	[2.05] 52	[5.00] 127	[91.9] 2335

① Available upon request