

FLEXON maxxTop Serie 843
maxxTop Series 843

843

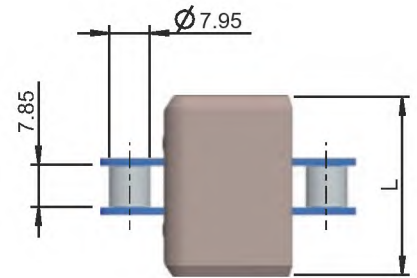

Werkstoff Platte Snap On material	LF
Werkstoff Grundkette Material base chain	C45, Edelstahl C45, Stainless steel
Teilung Grundkette Pitch base chain	1/2"
Rückbiegeradius Back flex radius	150 mm
Standardlänge Standard length	240 Pitches (10 feet - 3.048 m)

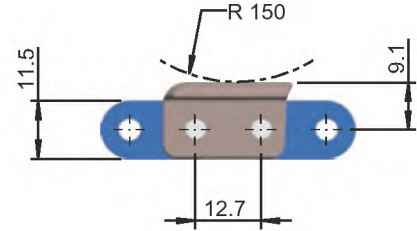
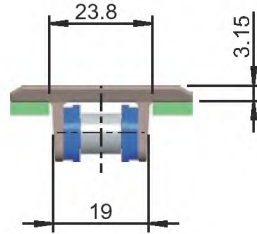
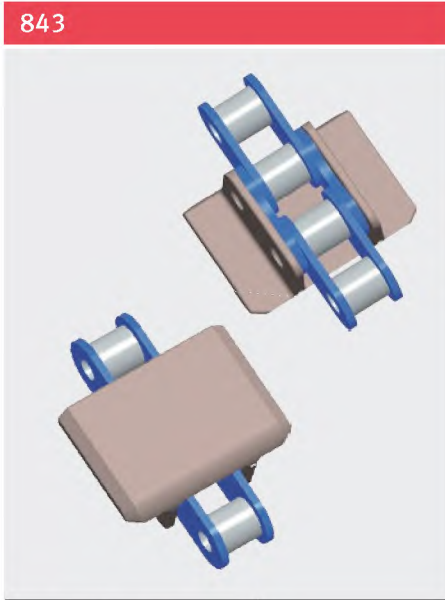
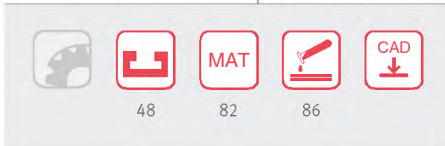

Kunststoffplatten fest montiert auf **Standard-Rollenketten**
Top plates ready assembled on **carbon steel base chain**

Kettentyp Chain ref	Werkstoff Material	Breite (L) Width		Durchschn. Bruchlast Average breaking load		Gewicht Weight	
		mm	inch	N	lbf	kg/m	lb/ft
LF843-K138	LF	34,9	1 3/8	13.800	3.100	0,83	0,56
LF843-K144		36,5	1 7/16			0,84	0,57
LF843-K200		50,8	2			0,89	0,60
LF843-K325		82,5	3 1/4			1,03	0,69

Kunststoffplatten fest montiert auf **Edelstahl-Rollenketten**
Top plates ready assembled on **stainless steel base chain**

Kettentyp Chain ref	Werkstoff Material	Breite (L) Width		Durchschn. Bruchlast Average breaking load		Gewicht Weight	
		mm	inch	N	lbf	kg/m	lb/ft
LF843SS-K138	LF	34,9	1 3/8	10.500	2.360	0,83	0,56
LF843SS-K144		36,5	1 7/16			0,84	0,57
LF843SS-K200		50,8	2			0,89	0,60
LF843SS-K325		82,5	3 1/4			1,03	0,69

SPEZIFIKATIONEN

- ANSI 40 Basiskette mit verlängertem Bolzen
- Einfaches Austauschen der aufgeschnappten Kunststoffplatten

CHARACTERISTICS

- ANSI 40 base chain with extended pins
- Easy to change out the snapped on top plates