



Falk Steelflex Grid Couplings

PRODUCT SHEET

You want a trusted name when it comes to providing power transmission products that improve productivity and efficiency. Known for durability in critical applications, Falk Steelflex® Grid Couplings combine the economy and high torque capacity of a gear coupling with the torsional flexibility and low maintenance of a disc or elastomeric coupling.

Falk Steelflex Grid Couplings are available in the widest range of sizes and accommodates the highest torque load of 8,250,000 lb-in (932,250 Nm). Offering a comprehensive set of options ensures the Falk Steelflex Coupling is the right product for an assortment of our customers' applications.

OUTPERFORMS THE COMPETITION

Third party testing has shown that Falk Steelflex Couplings are 4.7X and 16X more durable than the top two competitors, and capable of surviving up to 2X longer in real-life misalignment conditions. Steelflex's high-strength alloy steel grid elements are shot-peened and heat treated to reduce fatigue, resulting in increased uptime and MTBF in the most demanding applications.

ABSORBS SHOCK LOAD

When subjected to high-impact or vibratory loads, the Falk Steelflex Coupling torsionally deflects. The T-Grid design offers superior vibration damping and reduces peak torque loads, limiting wear on connected equipment components.

LOW MAINTENANCE

The "replace-in-place" design eliminates the need to move hubs or re-align shafts, reducing grid element change-out time. When lubricated with Falk Long Term Grease (LTG), the Falk Steelflex Coupling does not require re-lubrication for five years.

FIVE-YEAR HEAVY-DUTY WARRANTY

We're so confident in the performance and reliability of our Falk Steelflex Grid Couplings that they are warranted for 5 years when lubricated with Falk Long Term Grease (LTG). Other leading suppliers of grid couplings only offer a 12- or 18-month warranty.



OUR INNOVATION MOVES

Industries:

Cement & Aggregate
Paper & Forestry Products
Metal Forming
General Industrial

Applications:

- Paper machines
- Ball mills
- Hot bed rolls
- Bucket elevators
- Rail car dumpers
- Crushers
- Conveyors
- Blowers and fans
- Pumps

Available Options:

- T10 horizontal split cover
- T20 vertical split cover
- T31 full spacer
- T35 half spacer
- T41 & T44 controlled torque
- T50 piloted for floating shafts
- T63 disc brake
- T70 balanced high speed
- T90 flywheel
- BW brake wheel



T10 Close-Coupled
(Horizontally Split Cover)



T20 Close-Coupled
(Vertically Split Cover)



T31 Full Spacer
(Horizontally Split Cover)



T35 Half Spacer
(Horizontally Split Cover)



Tapered T-Grid profile fits smoothly into hub for easy installation and maintenance.

High-strength alloy steel grids are tempered to spring hardness and precision shot-peened for increased fatigue strength protecting equipment against shock and vibratory conditions.

Grade 5 cap screws ensure holding power to fasten the cover.

Durable, nitrile seals prevent loss of lubricant and entrance of water, dust or other contaminants.

Maximum bore capacity of 20" (508mm) with size 1260T.

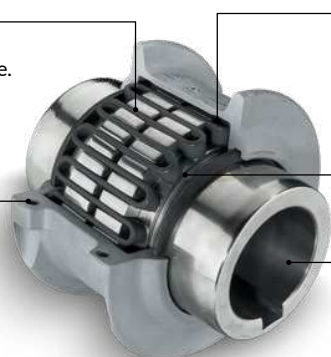

Size	Type T10 Close-Coupled		Type T20 Close-Coupled		Type T31 Full Spacer		Type T35 Half Spacer	
	Torque Rating (in-lbs / Nm)	Max Allowed Speed (RPM)	Torque Rating (in-lbs / Nm)	Max Allowed Speed (RPM)	Torque Rating (in-lbs / Nm)	Max Allowed Speed (RPM)	Torque Rating (in-lbs / Nm)	Max Allowed Speed (RPM)
1020T	460 / 52	4500	460 / 52	6000	460 / 52	3600	460 / 52	3600
1030T	1,320 / 149	4500	1,320 / 149	6000	1,320 / 149	3600	1,320 / 149	3600
1040T	2,200 / 249	4500	2,200 / 249	6000	2,200 / 249	3600	2,200 / 249	3600
1050T	3,850 / 435	4500	3,850 / 435	6000	3,850 / 435	3600	3,850 / 435	3600
1060T	6,050 / 684	4350	6,050 / 684	6000	6,050 / 684	3600	6,050 / 684	3600
1070T	8,800 / 994	4125	8,800 / 994	5500	8,800 / 994	3600	8,800 / 994	3600
1080T	18,150 / 2,051	3600	18,150 / 2,051	4750	18,150 / 2,051	3600	18,150 / 2,051	3600
1090T	33,000 / 3,729	3600	33,000 / 3,729	4000	33,000 / 3,729	3600	33,000 / 3,729	3600
1100T	55,550 / 6,277	2440	55,550 / 6,277	3600	55,550 / 6,277	2440	55,550 / 6,277	2440
1110T	82,500 / 9,323	2250	82,500 / 9,323	3000	82,500 / 9,323	2250	82,500 / 9,323	2250
1120T	121,000 / 13,673	2025	121,000 / 13,673	2700	121,000 / 13,673	2025	121,000 / 13,673	2025
1130T	176,000 / 19,888	1800	176,000 / 19,888	2400	176,000 / 19,888	1800	176,000 / 19,888	1800
1140T	253,000 / 28,589	1650	253,000 / 28,589	2200	253,000 / 28,589	1650	253,000 / 28,589	1650
1150T	352,000 / 39,776	1500	352,000 / 39,776	2000	352,000 / 39,776*	1500*	352,000 / 39,776*	1500*
1160T	495,000 / 55,935	1350	495,000 / 55,935	1750	495,000 / 55,935*	1350*	495,000 / 55,935*	1350*
1170T	660,000 / 74,580	1225	660,000 / 74,580	1600	660,000 / 74,580*	1225*	660,000 / 74,580*	1225*
1180T	915,000 / 103,395	1100	915,000 / 103,395*	1100*	915,000 / 103,395*	1100*
1190T	1,210,000 / 136,730	1050	1,210,000 / 136,730*	1050*	1,210,000 / 136,730*	1050*
1200T	1,650,000 / 186,450	900	1,650,000 / 186,450*	900*	1,650,000 / 186,450*	900*
1210T	2,200,000 / 248,600	820
1220T	2,970,000 / 335,610	730
1230T	3,850,000 / 435,050	680
1240T	4,950,000 / 559,350	630
1250T	6,600,000 / 745,800	580
1260T	8,250,000 / 932,250	540

* Type T31 and T35 couplings sizes 1150T to 1200T use Type G52 gear coupling rigid hubs as the shaft hubs.

See for yourself how Falk Steelflex couplings measured up against the competition by downloading the following white papers from the documentation section of www.rexnord.com.

- [CP4-002](#) Tests Reveal That All Grid Couplings Aren't the Same
- [CP4-003](#) "Fit-for-Fit" Grid Coupling Components Put to the Test

Refer to the Falk Steelflex Grid Couplings Catalogs for more information: **Metric** [421-110M](#) and **Inch** [421-110](#).



www.rexnord.com

866-REXNORD/866-739-6673 (Within the U.S.) or 414-643-2366 (Outside the U.S.)

Worldwide Support: www.rexnord.com/contact/worldwide-locations

