



**AIR TORQUE**

AIR TORQUE S.p.A.



**Model AT351 U  
D/S - 90°**

T.D.S. n° AT351U-DM  
Issued on: 04/10 - Page 1/1

**Dimensions in mm**

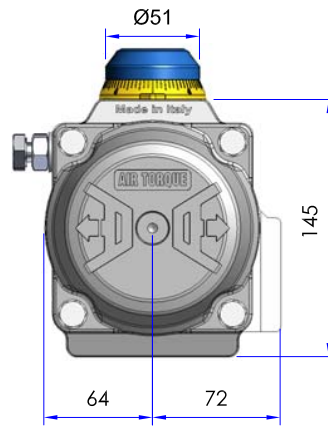
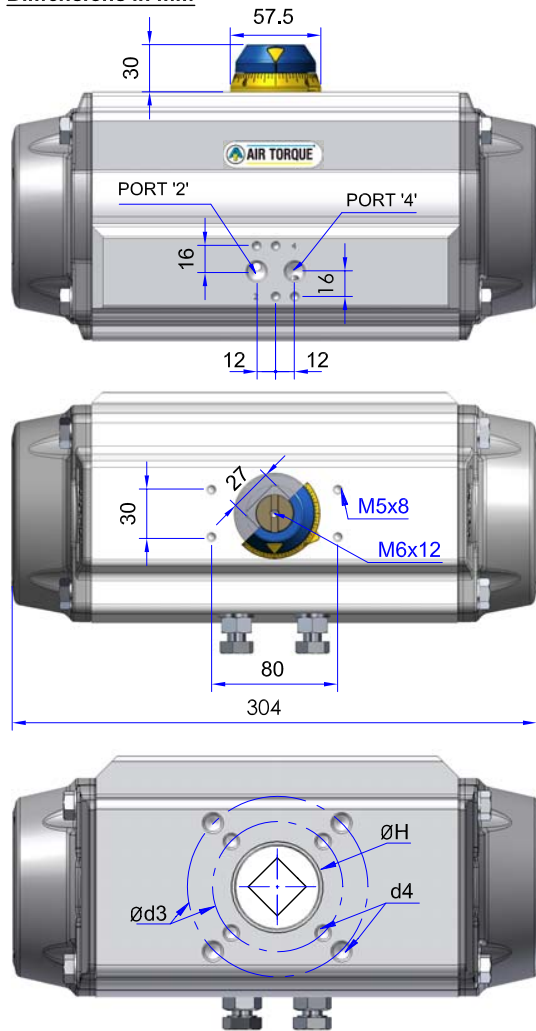

**ISO 5211 Flange Dimensions Available**

	STD	OPTIONAL
ISO 5211	F07 + F10	F10
Ø d2	55	70
Ø d3	70	102
d4	M8x12	M10x15
Ø H	55	70
Ch x l	14x19 - 22x24	
min. DS	17x25 - 22x24	
h min.	1,5	1,5
h1	2	2

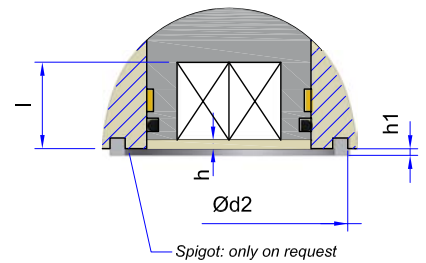

**Connection / Attachment**

Pressure connection: Port 2 and 4	G1/4"
Ancillary Attachment	AA 2

**Rotation and stroke adjustment**

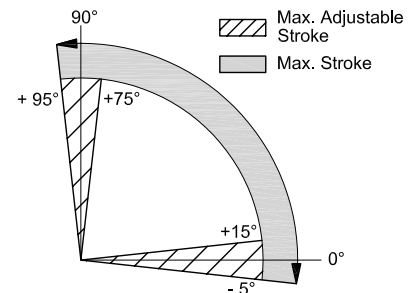

**Optional Square:**

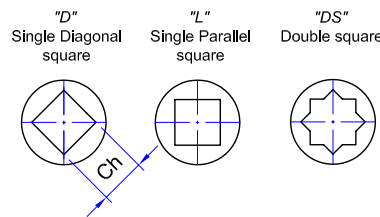

**Output Torque**

Pressure	OUTPUT TORQUE FOR DOUBLE ACTING IN Nm												APPROX. WEIGHT (Kg)	
	2,5 bar	3 bar	3,5 bar	4 bar	4,2 bar	4,5 bar	5 bar	5,5 bar	6 bar	7 bar	8 bar	8,07		
D	107	129	150	172	181	193	215	236	258	301	344			

Pressure	OUTPUT TORQUE FOR SPRING RETURN IN Nm												Spring stroke	APPROX. WEIGHT (Kg)
	2,5 bar	3 bar	3,5 bar	4 bar	4,2 bar	4,5 bar	5 bar	5,5 bar	6 bar	7 bar	8 bar			
Spring Set	Start End	Start End	Start End	Start End	Start End	Start End	Start End	Start End	Start End	Start End	Start End	Start End	End Start	
S 05	66,5 41,9	87,9 63,4	109 84,9	131 106	140 115	152 128	174 149						65,5 41	8,62
S 06	58,3 28,8	79,7 50,3	101 71,8	123 93,3	131 102	144 115	166 136	187 158					78,6 49,2	8,73
S 07		71,5 37,2	93 58,7	115 80,2	123 88,8	136 102	158 123	179 145	200 166				91,7 57,4	8,84
S 08			84,8 45,6	106 67,1	115 75,7	128 88,6	149 110	171 132	192 153	235,3 196			105 65,6	8,95
S 09				98,1 54	107 62,6	120 75,5	141 97	163 118	184 140	227,1 183	270 226		118 73,8	9,06
S 10						111 62,4	133 83,9	154 105	176 127	218,9 170	262 213		131 82	9,17
S 11							125 70,8	146 92,3	168 114	210,7 157	254 200		144 90,2	9,28
S 12								138 79,2	159 101	202,5 144	245 187		157 98,4	9,39

**Technical Data**

Max. Pressure	Rotation (For STD)	Screw stroke Adjustment	Chamber φ (mm)	Air Volume (L)		Moving Time (Sec.) (A)	
				Opening	Closing	Opening	Closing
8 bar	0° - 90°	For 1° adj. need 1/5 Turn	115	1,19	1,8	D 0,70 S 0,90	D 0,80 S 1,10

**Operating Temperature Range**

Operating Temperature (°C) (B)		
ST (standard)	HT (high temperature)	LLT (Extreme low temperature)
- 40 to + 80	- 15 to + 150	- 55 to + 80

A) - The above indicated moving time of the actuator is obtained in the following test conditions: (1) Room Temperature, (2) Actuator Stroke 90°, (3) Solenoid Valve with Orifice of 4 mm and a flow capacity Qn 400 L/min., (4) Inside pipe diameter 8 mm, (5) Medium clean air, (6) Air supply pressure 5,5 bar (79,75 Psi), (7) Actuator without external resistance load. **Caution: obviously on the field applications when one or more of the above parameters are different, the moving time will be different.**

B) - Every temperature range option requires proper components and lubricant. See technical data-sheet N° T.D.S. U00501E.

**Operating Medium:**

The operating medium must be free of dust and oil. The maximum particle size must not exceed 30µ (ISO 8573 Part1, Class5). In order to prevent water condensation and/or solidification (ice when actuator works below 0°C), the operating medium must have a dew point equal to -20°C or at least 10°C below the ambient temperature (ISO 8573 Part1, Class3).