

CATÁLOGO GENERAL  
ESLINGAS Y ACCESORIOS

## GRADO 80

ACCESORIOS

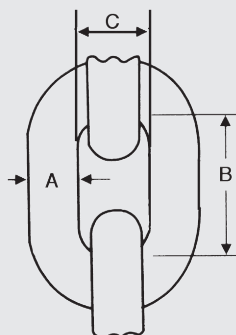

CADENA ALTA RESISTENCIA DIN EN-818-2 G.80						
CÓDIGO	MEDIDA (MM.)	C.M.T. TON.	PRINCIPALES DIMENSIONES EN (MM.)			PESO NETO (KGS.)
			A	B	C	
PHC1000	6-8	1,12	6	18	8,50	0,80
PHC2000	8-8	2,00	8	24	11	1,40
PHC3000	10-8	3,15	10	30	14	2,20
PHC4000	13-8	5,30	13	39	18	3,70
PHC5000	16-8	8,00	16	48	22	5,70
PHC6000	20-8	12,50	20	57	26	7,80
PHC7000	22-8	15,00	22	66	30	10,90
PHC8000	26-8	21,20	26	78	35	15,20
PHC9000	32-8	31,50	32	96	43	23,00

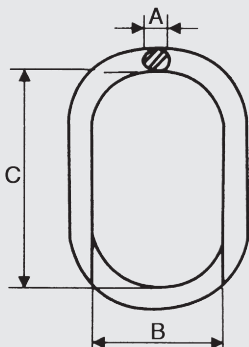

ANILLA OVALADA G.80						
CÓDIGO	MODELO	C.M.T. TON.	PRINCIPALES DIMENSIONES EN (MM.)			PESO NETO (KGS.)
			A	B	C	
PAN1000	AN76	1,60	13	60	110	0,40
PAN2000	AN87	2,12	16	60	110	0,55
PAN3000	AN108	3,15	18	75	135	0,80
PAN4000	AN1310	5,30	22	90	160	1,50
PAN5000	AN1613	8,00	26	100	180	2,30
PAN6000	AN1816	11,20	32	110	200	4,00
PAN7000	AN2018	14,00	36	140	260	6,50
PAN8000	AN2220	17,00	40	160	300	9,00
PAN9000	AN2622	21,20	45	180	340	13,00
PAN10000	AN3226	31,50	50	190	350	16,50
PAN11000	AN3632	45,00	56	200	400	23,50

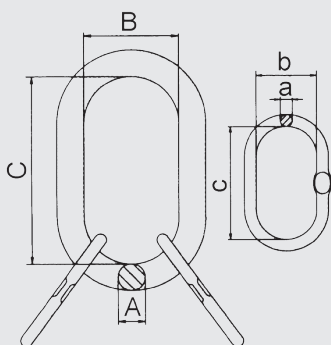

ANILLA MAESTRA G.80									
CÓDIGO	MEDIDA (MM.)	C.M.T. TON.	PRINCIPALES DIMENSIONES EN (MM.)						PESO NETO (KGS.)
			A	B	C	A	B	C	
PHAM1000	HA-06	2,36	18	77	133	14	26	56	1,30
PHAM2000	HA-08	4,25	22	89	156	16	33	72	2,20
PHAM3000	HA-10	6,70	25	99	180	18	41	87	3,20
PHAM4000	HA-13	11,20	31	111	196	22	52	115	6,00
PHAM5000	HA-16	17,00	36	131	261	25	65	140	9,50
PHAM6000	HA-20	26,50	50	191	353	32	89	185	23,50
PHAM7000	HA-22	31,50	51	191	354	37	106	180	25,40
PHAM8000	HA-26	45,00	57	210	410	40	105	183	35,50
PHAM9000	HA-32	74,80	70	252	420	50	116	200	59,60

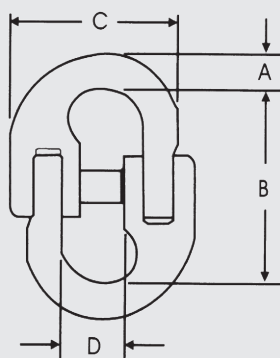

CONECTOR G.80							
CÓDIGO	MEDIDA (MM.)	C.M.T. TON.	PRINCIPALES DIMENSIONES EN (MM.)				PESO NETO (KGS.)
			A	B	C	D	
PHH1000	6-8	1,12	8	42	37	16	0,14
PHH2000	8-8	2,00	9	59	48	21	0,21
PHH3000	10-8	3,15	13	70	60	28	0,40
PHH4000	13-8	5,30	15	87	76	30	0,60
PHH5000	16-8	8,00	20	106	92	37	1,20
PHH6000	20-8	12,50	24	117	106	45	1,80
PHH7000	22-8	15,00	27	138	130	51	2,80
PHH8000	26-8	21,20	32	156	154	59	4,40
PHH9000	32-8	31,50	38	197	187	68	8,30



CÓDIGO	MEDIDA (MM.)	C.M.T. TON.	CONECTOR POLIÉSTER G.80						PESO NETO (KGS.)
			PRINCIPALES DIMENSIONES EN (MM.)						
			A	B	C	D	E	F	
PHHP100	6-8	1,12	16	60	55	35	18	8	0,20
PHHP200	8-8	2,00	20	62	64	37	23	9	0,30
PHHP300	10-8	3,15	26	66	80	37	30	13	0,50
PHHP400	13-8	5,30	30	87	94	51	36	16	1,10
PHHP500	16-8	8,00	36	107	120	64	45	22	2,00
PHHP600	20-8	12,50	44	127	134	78	50	23	2,90

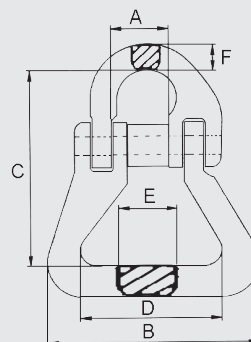

CÓDIGO	MEDIDA (MM.)	C.M.T. TON.	GANCHO CON PESTILLO G.80					PESO NETO (KGS.)
			PRINCIPALES DIMENSIONES EN (MM.)					
			A	B	C	D	E	
PG1000	6-8	1,12	20	79	24	9	14	0,30
PG2000	8-8	2,00	25	97	29	11	17	0,40
PG3000	10-8	3,15	38	118	30	15	21	0,90
PG4000	13-8	5,30	42	150	39	20	27	1,80
PG5000	16-8	8,00	50	183	47	23	35	2,90
PG6000	20-8	12,50	62	222	51	27	48	6,40
PG7000	22-8	15,00	62	235	75	33	43	9,00
PG8000	26-8	21,20	63	272	82	37	61	13,70
PG9000	32-8	31,50	87	350	103	39	65	19,30

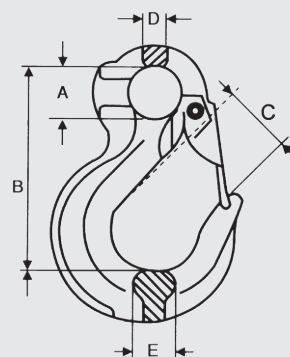

CÓDIGO	MEDIDA (MM.)	C.M.T. TON.	GANCHO CON PESTILLO CONEXIÓN DIRECTA G.80					PESO NETO (KGS.)
			PRINCIPALES DIMENSIONES EN (MM.)					
			A	B	C	D	E	
PGD1000	6-8	1,12	8	75	24	14	22	0,30
PGD2000	8-8	2,00	9	85	24	17	27	0,50
PGD3000	10-8	3,15	13	103	29	23	32	1,00
PGD4000	13-8	5,30	16	126	36	27	45	1,80
PGD5000	16-8	8,00	21	144	46	35	60	3,50
PGD6000	20-8	12,50	24	176	53	51	62	6,60

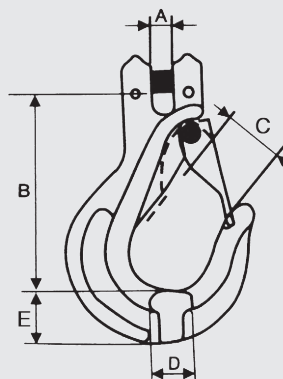

CÓDIGO	MEDIDA (MM.)	C.M.T. TON.	GANCHO DE SEGURIDAD G.80					PESO NETO (KGS.)
			PRINCIPALES DIMENSIONES EN (MM.)					
			A	B	C	D	E	
PGS1000	6-8	1,12	22	108	27	70	43	0,50
PGS2000	8-8	2,00	25	132	37	89	49	0,80
PGS3000	10-8	3,15	32	164	44	108	62	1,40
PGS4000	13-8	5,30	40	203	52	137	80	2,90
PGS5000	16-8	8,00	56	251	62	170	98	5,70
PGS6000	20-8	12,50	62	260	86	185	118	7,60
PGS7000	22-8	15,00	70	312	80	207	128	11,00
PGS8000	26-8	21,20	79	355	100	243	147	16,70
PGS9000	32-8	31,50	102	465	143	337	195	42,00

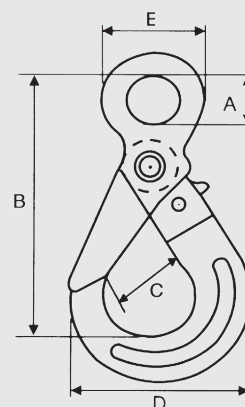

# GRADO 80

## ACCESORIOS

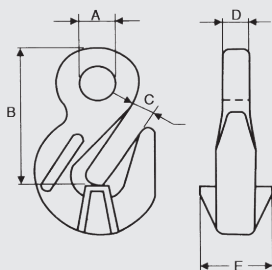
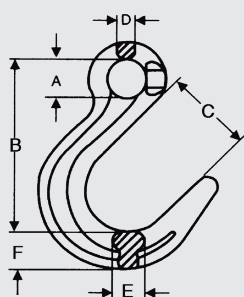
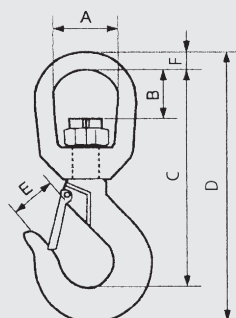
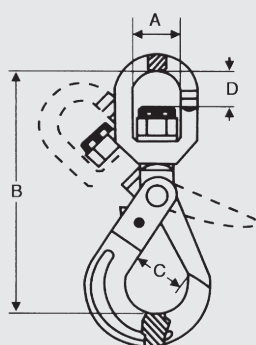
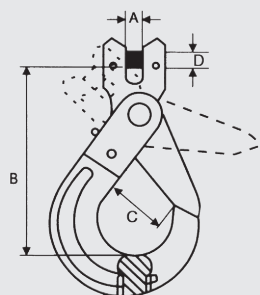

CÓDIGO	MEDIDA (MM.)	C.M.T. TON.	PRINCIPALES DIMENSIONES EN (MM.)				PESO NETO (KGS.)
			A	B	C	D	
			PGSD1000	6-8	1,12	9	
PGSD2000	8-8	2,00	9	108	37	9	0,80
PGSD3000	10-8	3,15	13	145	44	13	1,50
PGSD4000	13-8	5,30	15	175	52	16	3,10
PGSD5000	16-8	8,00	18	210	62	20	6,10
PGSD6000	20-8	12,50	25	230	86	25	7,90
PGSD7000	22-8	15,00	25	270	80	29	11,30

CÓDIGO	MEDIDA (MM.)	C.M.T. TON.	PRINCIPALES DIMENSIONES EN (MM.)				PESO NETO (KGS.)
			A	B	C	D	
			PGSG1000	6-8	1,12	33	
PGSG2000	8-8	2,00	35	183	37	27	1,10
PGSG3000	10-8	3,15	42	217	44	36	2,00
PGSG4000	13-8	5,30	49	260	52	40	3,70
PGSG5000	16-8	8,00	60	325	62	53	7,10
PGSG6000	20-8	12,50	72	352	86	58	9,80
PGSG7000	22-8	15,00	96	455	80	93	17,20
PGSG8000	26-8	21,20	121	525	100	113	29,80

Advertencia: Sólo girar el gancho sin carga.

CÓDIGO	MEDIDA (MM.)	C.M.T. TON.	PRINCIPALES DIMENSIONES EN (MM.)						PESO NETO (KGS.)
			A	B	C	D	E	F	
			PGG1000	6-8	1,12	32	26	112	
PGG2000	8-8	2,00	44	37	150	190	25	15	1,00
PGG3000	10-8	3,15	44	37	160	206	28	15	1,20
PGG4000	13-8	5,30	50	43	187	242	35	18	1,90
PGG5000	16-8	8,00	64	56	242	310	43	25	4,00
PGG6000	20-8	12,50	70	53	274	360	52	28	7,60
PGG7000	22-8	15,00	79	64	327	431	59	29	12,50

Advertencia: Sólo girar el gancho sin carga.

CÓDIGO	MEDIDA (MM.)	C.M.T. TON.	PRINCIPALES DIMENSIONES EN (MM.)						PESO NETO (KGS.)
			A	B	C	D	E	F	
			PGF1000	6-8	1,12	18	118	62	
PGF2000	8-8	2,00	18	118	62	12	24	31	1,00
PGF3000	10-8	3,15	22	146	75	17	33	38	2,00
PGF4000	13-8	5,30	27	173	87	19	38	44	3,10
PGF5000	16-8	8,00	32	198	98	19	45	53	5,10
PGF6000	20-8	12,50	37	230	111	26	57	65	9,10
PGF7000	22-8	15,00	44	258	124	29	60	68	11,70

CÓDIGO	MEDIDA (MM.)	C.M.T. TON.	PRINCIPALES DIMENSIONES EN (MM.)					PESO NETO (KGS.)
			A	B	C	D	E	
			PGA1000	6-8	1,12	14	45	
PGA2000	8-8	2,00	16	59	10	9	30	0,20
PGA3000	10-8	3,15	20	79	13	14	46	0,60
PGA4000	13-8	5,30	26	99	16	16	57	1,30
PGA5000	16-8	8,00	30	102	19	19	71	2,00
PGA6000	20-8	12,50	36	130	22	22	93	4,80
PGA7000	22-8	15,00	44	160	27	28	90	7,40
PGA8000	26-8	21,20	44	184	28	35	100	10,00
PGA9000	32-8	31,50	55	230	37	42	113	18,00



GANCHO ACORTADOR CON PESTILLO CONEXIÓN DIRECTA G.80										
CÓDIGO	MEDIDA (MM.)	C.M.T. TON.	PRINCIPALES DIMENSIONES EN (MM.)							PESO NETO (KGS.)
			A	B	C	D	E	F	G	
PGAPD1000	6-8	1,12	8	32	8	26	6	43	75	0,20
PGAPD2000	8-8	2,00	9	35	11	33,50	11	50	89	0,33
PGAPD3000	10-8	3,15	12	45	13	46	12	70	126	0,88
PGAPD4000	13-8	5,30	15	53	16	57	13	96	163	1,85
PGAPD5000	16-8	8,00	18	69	19	72	17	112	183	3,24

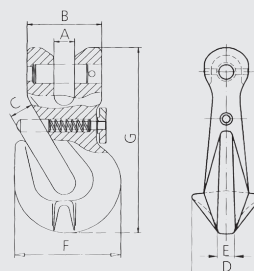

GANCHO ACORTADOR CAZOLETA G.80								
CÓDIGO	MEDIDA (MM.)	C.M.T. TON.	PRINCIPALES DIMENSIONES EN (MM.)					PESO NETO (KGS.)
			A-B	C	D	E	F	
PGAD1000	6-8	1,12	7	8	7	14	45	0,30
PGAD2000	8-8	2,00	9	11	11	20	64	0,50
PGAD3000	10-8	3,15	12	13	13	22	87	1,00
PGAD4000	13-8	5,30	16	16	16	32	114	2,00
PGAD5000	16-8	8,00	20	20	21	38	135	3,50
PGAD6000	20-8	12,50	22	25	24	47	151	4,30
PGAD7000	22-8	15,00	24	28	27	57	185	7,80

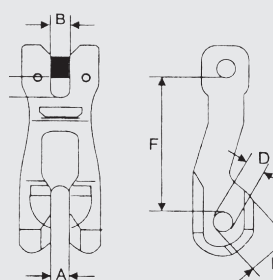

GANCHO CORREDIZO G.80						
CÓDIGO	MEDIDA (MM.)	C.M.T. TON.	PRINCIPALES DIMENSIONES EN (MM.)			PESO NETO (KGS.)
			PGCOR2000	B	C	
PGCOR2000	8-8	2,00	30	90	17	0,40
PGCOR3000	10-8	3,15	39	116	21	0,70
PGCOR4000	13-8	5,30	51	143	27	1,50
PGCOR5000	16-8	8,00	65	180	32	3,20

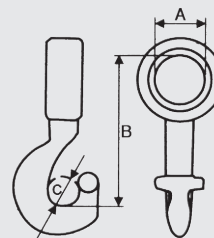

CONECTOR OMEGA G.80							
CÓDIGO	MEDIDA (MM.)	C.M.T. TON.	PRINCIPALES DIMENSIONES EN (MM.)				PESO NETO (KGS.)
			A	B	C	D	
POMEG2000	8-8	2,00	22	34	10	11	0,20
POMEG3000	10-8	3,15	31	40	12	16	0,30
POMEG4000	13-8	5,30	40	54	16	20	0,70
POMEG5000	16-8	8,00	48	61	18	26	1,10

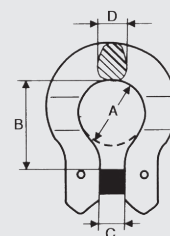

GANCHO PARA SER SOLDADO (EXCAVADORA) G.80										
CÓDIGO	MEDIDA (MM.)	C.M.T. TON.	PRINCIPALES DIMENSIONES EN (MM.)							PESO NETO (KGS.)
			A	B	C	D	E	F	G	
PGSOL100	GE-2	2,00	91	80	26	24	20	34	7	0,80
PGSOL200	GE-3	3,00	106	115	30	30	24	36	9	1,20
PGSOL300	GE-5	5,00	132	159	36	45	28	44	10	2,50
PGSOL400	GE-8	8,00	133	164	36	51	40	53	16	3,50
PGSOL500	GE-10	10,00	166	200	48	55	39	56	20	5,60

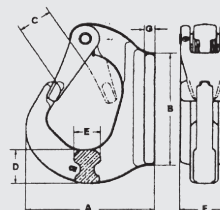

GANCHO S							
CÓDIGO	MEDIDA (MM.)	C.M.T. TON.	PRINCIPALES DIMENSIONES EN (MM.)				PESO NETO (KGS.)
			A	B	C	D	
PS10150	S-10	0,15	10	115	28	28	0,15
PS12250	S-12	0,25	12	153	38	38	0,30
PS14350	S-14	0,35	14	190	50	50	0,50
PS16500	S-16	0,50	16	230	63	63	0,80
PS20750	S-20	0,75	20	267	76	76	1,50
PS221000	S-22	1,00	22	305	88	88	2,00
PS261300	S-26	1,30	26	331	100	100	3,20
PS281500	S-28	1,50	28	380	115	115	4,20
PS322000	S-32	2,00	32	407	127	127	6,00

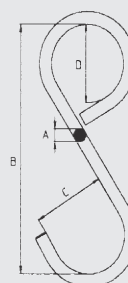

CATÁLOGO GENERAL  
ESLINGAS Y ACCESORIOS

## GRADO 80

ACCESORIOS

# Mantenimiento y cuidado



### Mantenimiento

Una inspección periódica debe realizarse, con arreglo a las condiciones de aplicación, en periodos regulares y al menos una vez al año. Los siguientes puntos deben tenerse en cuenta.

- Las cadenas con eslabones deformados, con fisuras o grietas, deben ser retiradas así como cualquier accesorio, anillas maestras deformadas, ganchos abiertos y otros componentes que muestren señales de deterioro.
- El desgaste de la cadena y los componentes no excederá del 10% de las dimensiones originales. El desgaste del eslabón de la cadena será un máximo del 10%, se define como la reducción del diámetro del material medido en dos direcciones.
- Las eslingas de cadena sobrecargadas deben de ser retiradas de su uso, el alargamiento máximo permitido de la cadena es el 5% y el incremento máximo permitido de la apertura del gancho es de un 10%. Todo lo que exceda debe retirarse de su uso.

### Cuidado

- Guarde un registro de todas las eslingas en uso.
- Asegurarse que la cadena esté libre, es decir, sin nudos ni torcida.
- Las eslingas de cadena solo se acortarán con un gancho acortador.
- Si la carga presenta aristas vivas, proteger la carga adecuadamente.
- Centrar la carga en el gancho, nunca cargue en la punta del gancho.
- Siempre use la eslinga de medidas adecuadas para la carga correspondiente, tenga en cuenta el ángulo y la posibilidad de una carga desigual.
- La anilla principal debe moverse libremente en el gancho de la grúa.
- Evitar siempre los tirones en el curso de elevación de las cargas.
- No dejar caer nunca la carga sobre la cadena.