

DGE



DG [DRAGA]



- Cast iron vortex impeller
- Large free passage

- Sewage
- Soiled wastewaters with solids
- Lifting stations in civil and residential plants

DRE



DR [DRENO]

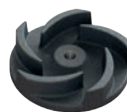

- Cast iron multi-channel open impeller
- Stainless steel suction strainer

- Clear or slightly soiled wastewaters
- Strained, seepage and underground pump-out waters
- Garden sprinklers and pumping from tanks

Range characteristics

Power supply	220/240V ~1 - 380/400V ~3
Frequency	50 Hz
Power	0.37 ÷ 1.5 kW
Poles	2
Discharge	vertical G 1½" - G 2"
	horizontal G 2" - DN50
Free passage	max 50 mm
Max flow rate	696 l/min
Max head	15.7 m

Power supply	220/240V ~1 - 380/400V ~3
Frequency	50 Hz
Power	0.3 ÷ 0.74 kW
Poles	2
Discharge	vertical G 1¼" - G 2"
	horizontal G 2" - DN50
Free passage	max 15 mm
Max flow rate	756 l/min
Max head	18.0 m

E Series



HANDLE

Stainless steel lifting and carrying handle.



CASE

Rugged cast iron construction.

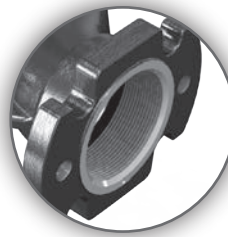

DISCHARGE PORT

Wide range of models with vertical or horizontal discharge, with threaded or flanged connections for absolutely flexible installation.

FEET

The rugged feet integral in the cast iron case give the pump stability and keep it at the correct suction height with no additional accessories required.

Highlight



STRUCTURE

Pump body dismantles for easy maintenance of internal components.

E Series

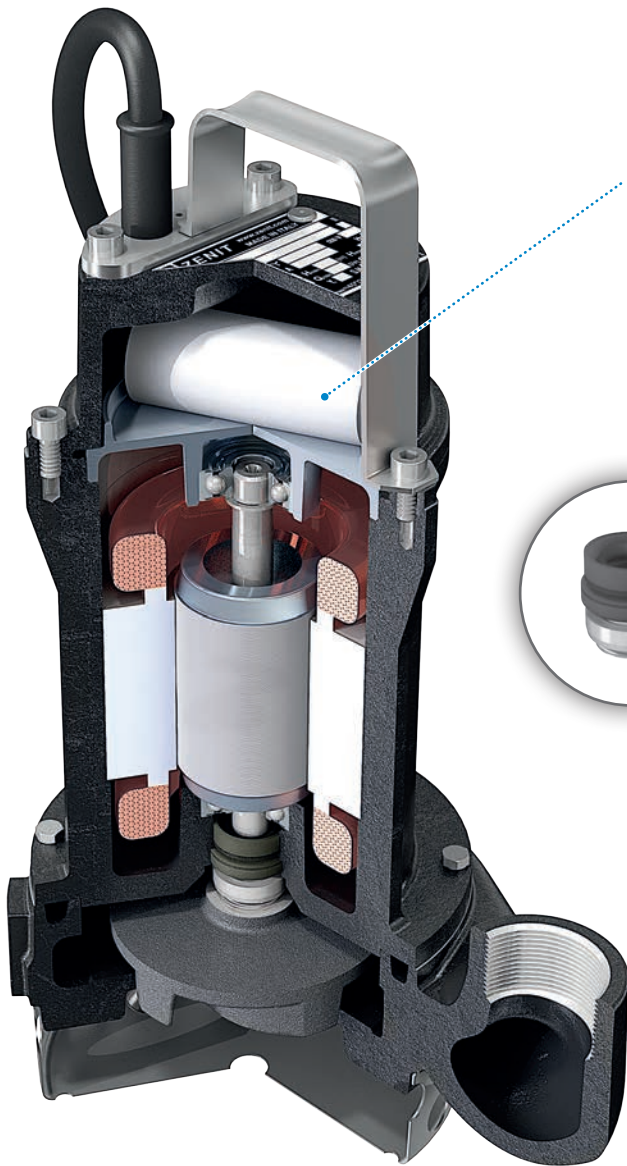

CAPACITOR/RELAY

Single-phase models have internal capacitor. Three-phase models are equipped with thermal protection and relay to safeguard the motor (optional).



MECHANICAL SEALS

One mechanical seal in silicon carbide (SiC) and one lip seal.

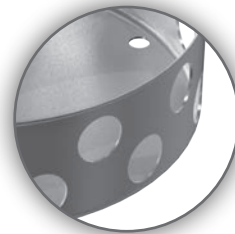

STRAINER [DRE]

Stainless steel suction strainer.



FREE PASSAGE [DGE]

Ample free passage allowing the expulsion of solids and preventing fouling of the impeller.

ANTI-CLOGGING SYSTEM [DRE]

The specially shaped hydraulics ensure the expulsion of small suspended solids and prevent fouling of the impeller.



Models with vertical threaded discharge [GAS 1½"] - 2 poles

Performances

	l/s	0	2	4	6	8
	l/min	0	120	240	360	480
	m³/h	0	7.2	14.4	21.6	28.8
① DGE 100/2/G40V A0CM[T]5			11.1	7.9	3.7	
② DGE 150/2/G40V A0CM[T]5			13.1	9.8	5.7	
③ DGE 200/2/G40V A0CM[T]5			14.7	11.6	7.9	3.5

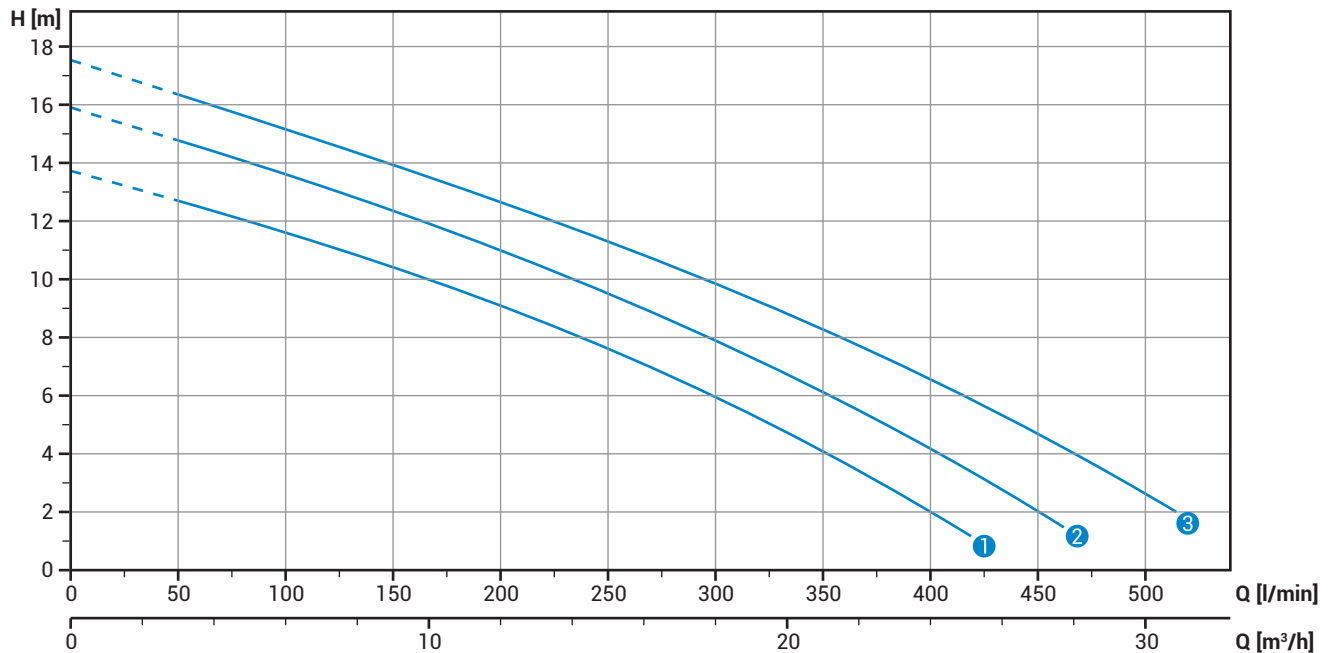

Technical data

	V	Phases	P1 [kw]	P2 [kw]	A	Rpm	Ø	Free passage
① DGE 100/2/G40V A0CM5	230	1	-	0.88	6.0	2900	G 1½"	40 mm
② DGE 150/2/G40V A0CM5	230	1	-	1.10	7.6	2900	G 1½"	40 mm
③ DGE 200/2/G40V A0CM5	230	1	-	1.50	8.9	2900	G 1½"	40 mm
① DGE 100/2/G40V A0CT5	400	3	-	0.88	2.0	2900	G 1½"	40 mm
② DGE 150/2/G40V A0CT5	400	3	-	1.10	2.5	2900	G 1½"	40 mm
③ DGE 200/2/G40V A0CT5	400	3	-	1.50	3.2	2900	G 1½"	40 mm

Models with vertical threaded discharge [GAS 2"] - 2 poles

Performances

	l/s	0	2	4	6	8	10
	l/min	0	120	240	360	480	600
	m³/h	0	7.2	14.4	21.6	28.8	36.0
① DGE 50/2/G50V B0BM[T]5			4.9	2.6			
② DGE 75/2/G50V B0BM[T]5			6.7	4.7	2.0		
③ DGE 100/2/G50V B0CM[T]5			10.1	7.9	5.6	3.4	
④ DGE 150/2/G50V B0CM[T]5			11.9	9.6	7.2	4.8	2.4
⑤ DGE 200/2/G50V B0CM[T]5			13.6	11.2	8.8	6.3	3.9

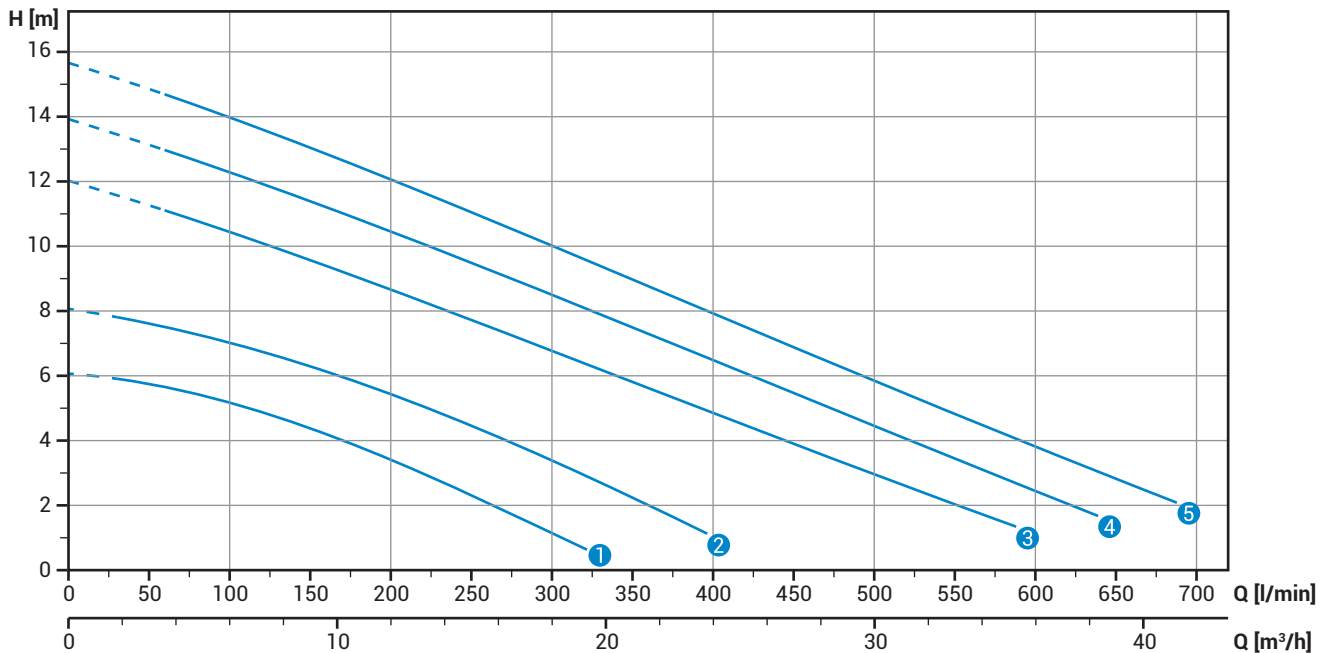

Technical data

	V	Phases	P1 [kW]	P2 [kW]	A	Rpm	Ø	Free passage
① DGE 50/2/G50V B0BM5	230	1	-	0.37	2.8	2900	G 2"	40 mm
② DGE 75/2/G50V B0BM5	230	1	-	0.55	3.6	2900	G 2"	40 mm
③ DGE 100/2/G50V B0CM5	230	1	-	0.88	6.5	2900	G 2"	50 mm
④ DGE 150/2/G50V B0CM5	230	1	-	1.10	8.2	2900	G 2"	50 mm
⑤ DGE 200/2/G50V B0CM5	230	1	-	1.50	9.4	2900	G 2"	50 mm
① DGE 50/2/G50V B0BT5	400	3	-	0.37	1.1	2900	G 2"	40 mm
② DGE 75/2/G50V B0BT5	400	3	-	0.55	1.3	2900	G 2"	40 mm
③ DGE 100/2/G50V B0CT5	400	3	-	0.88	2.2	2900	G 2"	50 mm
④ DGE 150/2/G50V B0CT5	400	3	-	1.10	2.6	2900	G 2"	50 mm
⑤ DGE 200/2/G50V B0CT5	400	3	-	1.50	3.6	2900	G 2"	50 mm

Models with horizontal flanged and threaded discharge [GAS 2" - DN50 PN10-16] - 2 poles

Performances

	l/s	0	2	4	6	8	10
	l/min	0	120	240	360	480	600
	m ³ /h	0	7.2	14.4	21.6	28.8	36.0
① DGE 50/2/G50H A1BM[T]5			5.3	3.4	1.0		
② DGE 75/2/G50H A1BM[T]5			6.3	4.3	2.2		
③ DGE 100/2/G50H A0CM[T]5			10.2	7.8	5.3	2.8	
④ DGE 150/2/G50H A0CM[T]5			11.9	9.8	7.5	5.1	2.7
⑤ DGE 200/2/G50H A0CM[T]5			13.2	10.8	8.3	6.0	3.7

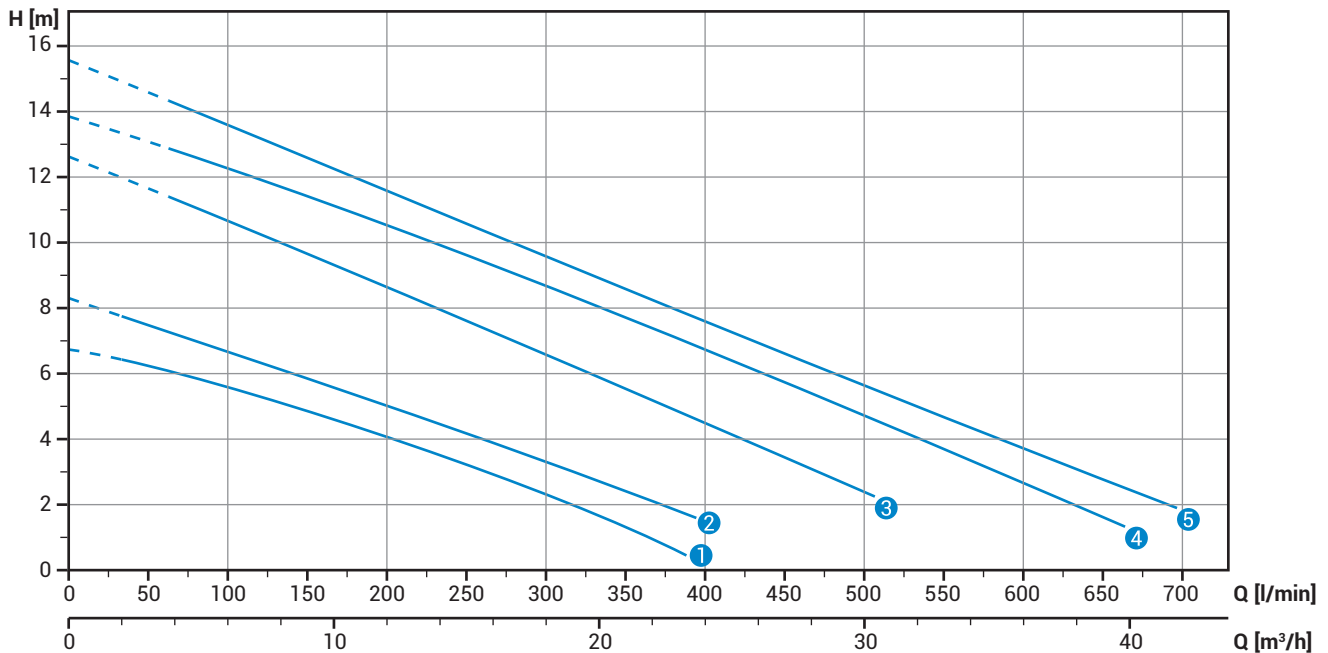

Technical data

	V	Phases	P1 [kw]	P2 [kw]	A	Rpm	Ø	Free passage
① DGE 50/2/G50H A1BM5	230	1	-	0.37	2.8	2900	G 2"- DN50 PN10-16	35 mm
② DGE 75/2/G50H A1BM5	230	1	-	0.55	3.6	2900	G 2"- DN50 PN10-16	35 mm
③ DGE 100/2/G50H A0CM5	230	1	-	0.88	6.5	2900	G 2"- DN50 PN10-16	50 mm
④ DGE 150/2/G50H A0CM5	230	1	-	1.10	8.2	2900	G 2"- DN50 PN10-16	50 mm
⑤ DGE 200/2/G50H A0CM5	230	1	-	1.50	9.4	2900	G 2"- DN50 PN10-16	50 mm
① DGE 50/2/G50H A1BT5	400	3	-	0.37	1.1	2900	G 2"- DN50 PN10-16	35 mm
② DGE 75/2/G50H A1BT5	400	3	-	0.55	1.3	2900	G 2"- DN50 PN10-16	35 mm
③ DGE 100/2/G50H A0CT5	400	3	-	0.88	2.2	2900	G 2"- DN50 PN10-16	50 mm
④ DGE 150/2/G50H A0CT5	400	3	-	1.10	2.6	2900	G 2"- DN50 PN10-16	50 mm
⑤ DGE 200/2/G50H A0CT5	400	3	-	1.50	3.6	2900	G 2"- DN50 PN10-16	50 mm

Dimensions

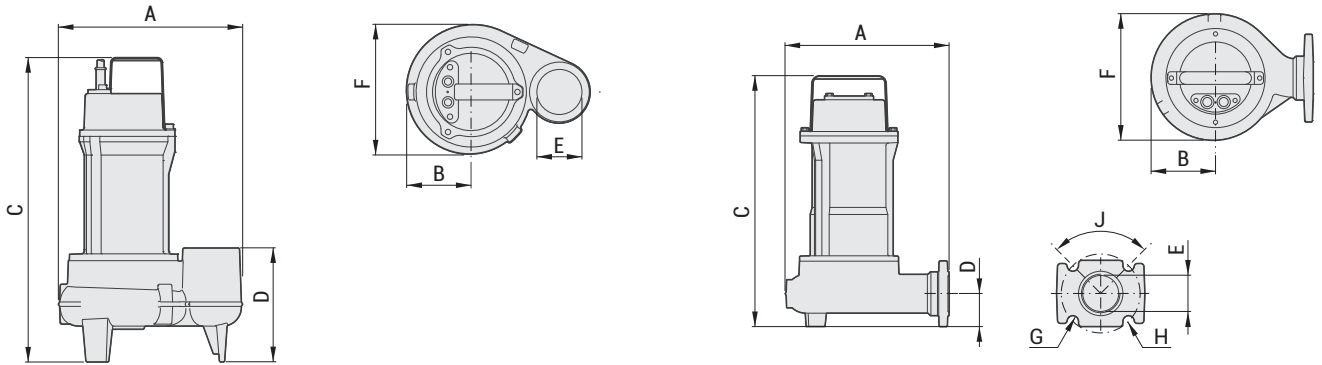

Overall dimensions (mm)

	A	B	C	D	E	F	G	H	J	kg	X	Y	Z
DGE 100/2/G40V A0CM[T]5	260	100	405	125	GAS 1 1/2"	205	-	-	-	19	285	475	235
DGE 150/2/G40V A0CM[T]5	260	100	405	125	GAS 1 1/2"	205	-	-	-	20	285	475	235
DGE 200/2/G40V A0CM[T]5	260	100	405	125	GAS 1 1/2"	205	-	-	-	21	285	475	235
DGE 50/2/G50V B0BM[T]5	230	80	385	120	GAS 2"	165	-	-	-	12	225	385	245
DGE 75/2/G50V B0BM[T]5	230	80	385	120	GAS 2"	165	-	-	-	14	225	385	245
DGE 100/2/G50V B0CM[T]5	270	100	100	130	GAS 2"	205	-	-	-	19	285	475	235
DGE 150/2/G50V B0CM[T]5	270	100	100	130	GAS 2"	205	-	-	-	20	285	475	235
DGE 200/2/G50V B0CM[T]5	270	100	100	150	GAS 2"	205	-	-	-	21	285	475	235
DGE 50/2/G50H A1BM[T]5	220	80	365	65	GAS 2" - DN50	160	18	125	90°	12	225	385	245
DGE 75/2/G50H A1BM[T]5	220	80	365	65	GAS 2" - DN50	160	18	125	90°	14	225	385	245
DGE 100/2/G50H A0CM[T]5	260	100	430	80	GAS 2" - DN50	205	18	125	90°	19	285	475	235
DGE 150/2/G50H A0CM[T]5	260	100	430	80	GAS 2" - DN50	205	18	125	90°	20	285	475	235
DGE 200/2/G50H A0CM[T]5	260	100	430	80	GAS 2" - DN50	205	18	125	90°	21	285	475	235

Versions

Single-phase models

- TC Thermal protection, capacitor
- TCG Thermal protection, capacitor, float switch

Three-phase models

- NAE No electric accessory
- TRG Thermal protection, relay for motor protection, float switch

Installations

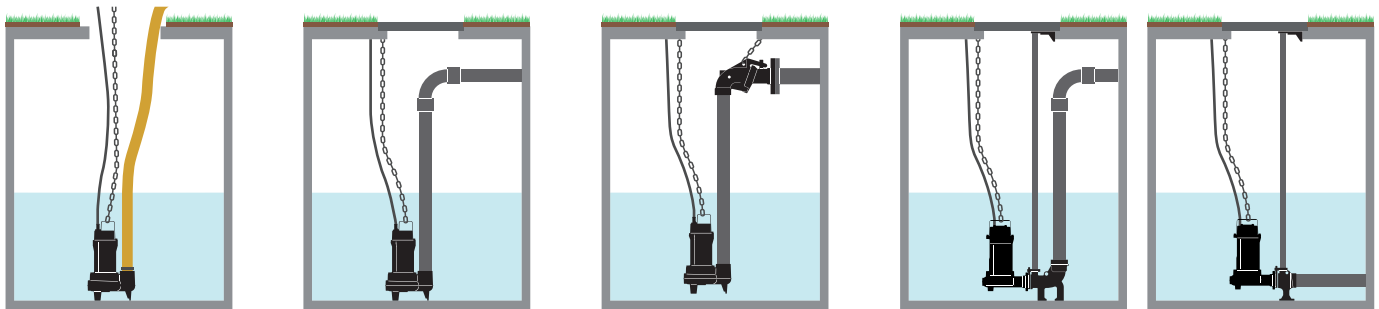

FREE

FIXED

WITH EXTERNAL COUPLER
[DAC-E - Page 78]

WITH BASE COUPLING FOOT
[DAC-V - Page 79]

WITH BASE COUPLING FOOT
[DAC-H - Page 80]