

RD 82

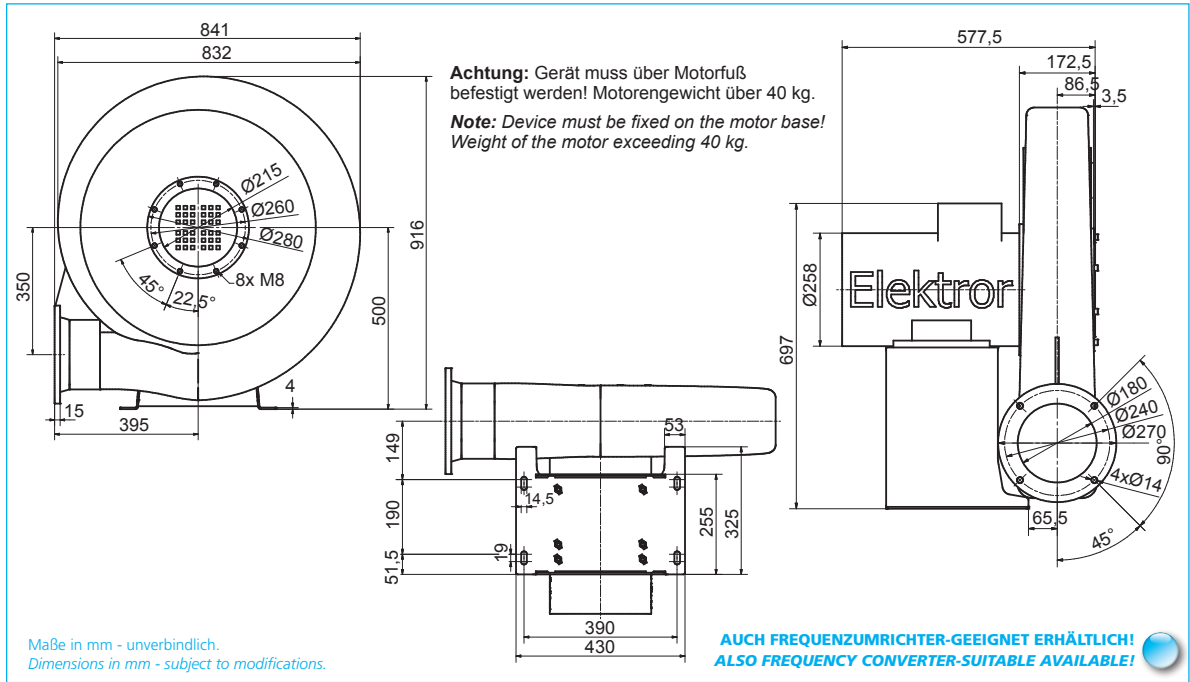

Typ	Effizienzklasse Efficiency class	Frequenz	Volumenstrom	Gesamtdruckdifferenz	Spannung	Stromaufnahme	Drehzahl	Motorleistung	Gewicht (ca.)
Type	Efficiency class	Frequency	Volumetric flow rate	Total pressure difference	Voltage	Current consumption	Number of revolutions	Motor rating	Weight (approx.)
RD 82	IE3	50	88,0	5200	400 Δ	13,4	2935	7,5	111
	IE3	60	88,0	5700	400 Δ	16,1	3530	9,00	111
	NEMA*	60	88,0	5700	480 Δ	13,4	3530	9,00	111

\* NEMA Premium

Elektor

50 Hz

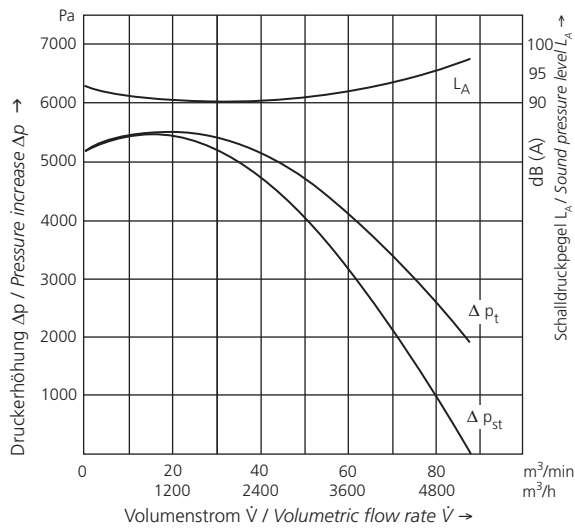

60 Hz

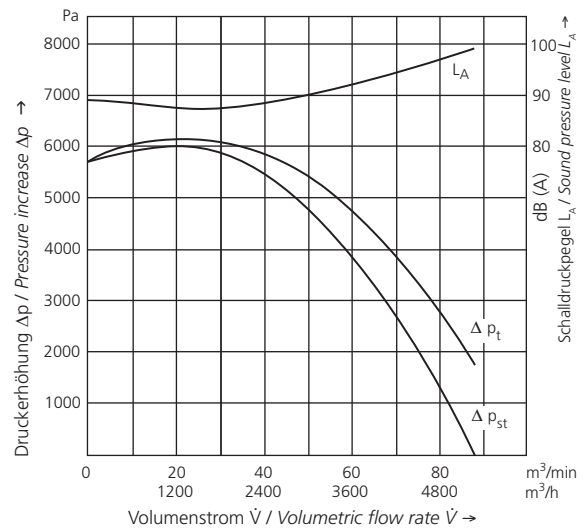

Technische und konstruktive Änderungen vorbehalten.  
 Technical and constructional subject to change.

04.20/09